



# PACKAGED ROOFTOP AIR CONDITIONING UNITS

INSTALLATION, OPERATION, MAINTENANCE

Supersedes 100.50-NOM9 (1115)

Form 100.50-NOM9 (116)

035-22722-010

## SERIES 100 SINGLE PACKAGED UNITS YPAL DESIGN LEVEL F

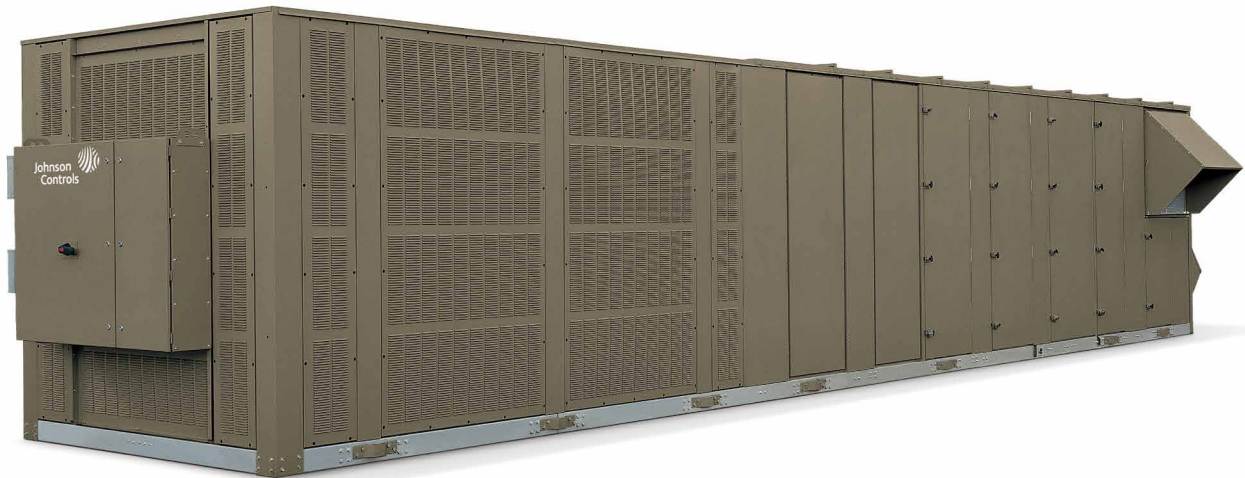

LD16707

### 70 THROUGH 105 TONS



Issue Date:  
January 7, 2016



# IMPORTANT!

## READ BEFORE PROCEEDING!

### GENERAL SAFETY GUIDELINES

This equipment is a relatively complicated apparatus. During rigging, installation, operation, maintenance, or service, individuals may be exposed to certain components or conditions including, but not limited to: heavy objects, refrigerants, materials under pressure, rotating components, and both high and low voltage. Each of these items has the potential, if misused or handled improperly, to cause bodily injury or death. It is the obligation and responsibility of rigging, installation, and operating/service personnel to identify and recognize these inherent hazards, protect themselves, and proceed safely in completing their tasks. Failure to comply with any of these requirements could result in serious damage to the equipment and the property in

which it is situated, as well as severe personal injury or death to themselves and people at the site.

This document is intended for use by owner-authorized rigging, installation, and operating/service personnel. It is expected that these individuals possess independent training that will enable them to perform their assigned tasks properly and safely. It is essential that, prior to performing any task on this equipment, this individual shall have read and understood the on-product labels, this document and any referenced materials. This individual shall also be familiar with and comply with all applicable industry and governmental standards and regulations pertaining to the task in question.

---

## SAFETY SYMBOLS

The following symbols are used in this document to alert the reader to specific situations:



*Indicates a possible hazardous situation which will result in death or serious injury if proper care is not taken.*

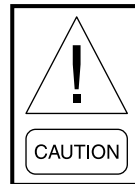

*Identifies a hazard which could lead to damage to the machine, damage to other equipment and/or environmental pollution if proper care is not taken or instructions and are not followed.*



*Indicates a potentially hazardous situation which will result in possible injuries or damage to equipment if proper care is not taken.*

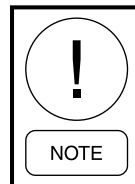

*Highlights additional information useful to the technician in completing the work being performed properly.*



*External wiring, unless specified as an optional connection in the manufacturer's product line, is not to be connected inside the control cabinet. Devices such as relays, switches, transducers and controls and any external wiring must not be installed inside the micro panel. All wiring must be in accordance with Johnson Controls' published specifications and must be performed only by a qualified electrician. Johnson Controls will NOT be responsible for damage/problems resulting from improper connections to the controls or application of improper control signals. Failure to follow this warning will void the manufacturer's warranty and cause serious damage to property or personal injury.*

## CHANGEABILITY OF THIS DOCUMENT

In complying with Johnson Controls' policy for continuous product improvement, the information contained in this document is subject to change without notice. Johnson Controls makes no commitment to update or provide current information automatically to the manual or product owner. Updated manuals, if applicable, can be obtained by contacting the nearest Johnson Controls Service office or accessing the Johnson Controls QuickLIT website at <http://cgproducts.johnsoncontrols.com>.

It is the responsibility of rigging, lifting, and operating/service personnel to verify the applicability of these documents to the equipment. If there is any question

regarding the applicability of these documents, rigging, lifting, and operating/service personnel should verify whether the equipment has been modified and if current literature is available from the owner of the equipment prior to performing any work on the chiller.

### CHANGE BARS

Revisions made to this document are indicated with a line along the left or right hand column in the area the revision was made. These revisions are to technical information and any other changes in spelling, grammar or formatting are not included.

---

## ASSOCIATED LITERATURE

MANUAL DESCRIPTION	FORM NUMBER
Shipping Damage Claims	50.15-NM
Installation Instructions	100.50-N1
Installation, Operation & Maintenance Manual	100.40-NO4
Literature Supplement (dated 706)	100.40-NO4 (LS02)
Quick Start-Up Guide	100.50-SU1

# NOMENCLATURE

## BASE MODEL NUMBER

<u>1</u>	<u>2</u>	<u>3</u>	<u>4</u>	<u>5</u>	<u>6</u>	<u>7</u>	<u>8</u>	<u>9</u>	<u>10</u>	<u>11</u>	<u>12</u>	<u>13</u>	<u>14</u>	<u>15</u>	<u>16</u>	<u>17</u>
BASE PRODUCT TYPE				NOMINAL CAPACITY			APPLICATION		REFRIGERANT	VOLTAGE		DUCT LOCATIONS		DESIGN SPECIAL	GAS HEAT CAPACITY	
L : Scroll				0	7	0	C : Constant Volume		E : R-410A	1	7	B : Bottom Return		N : No Gas Heat		
A : Air-Cooled				0	7	5	V : VAV, VFD			2	8	R : Rear Return		L : Low (375 MBH)		
P : Packaged Rooftop				0	8	0	F : FlexSys			4	6	S : Side Return		M : Med (750 MBH)		
Y : YORK				0	9	0	C : Cooling Only			5	8			H : High (1125 MBH)		
				1	0	5	N : Natural Gas Heat			4	0			A : Std. Product, Simplicity Elite		
							G : Natural Gas Heat SS HX							B : Special Product, Simplicity Elite		
							M : Modulating Gas Heat							X : Std. Product, IPU		
							E : Electric Heat							S : Special Product, IPU		
							S : Steam Heat							F		
							H : Hot Water Heat									

## TABLE OF CONTENTS

<b>SECTION 1 – INTRODUCTION</b> .....	<b>13</b>
Ecological And Economical Design .....	13
Cooling and Heating.....	13
Indoor Air Quality (IAQ).....	13
High-Efficiency Motors .....	13
Modulating Gas Heat.....	13
Condensing Section .....	13
Scroll Compressors .....	13
Multiple Compressor Staging .....	13
Compressor Circuiting.....	14
Compressor Sound Blankets.....	14
Replaceable Core Filter Driers .....	14
Low Ambient Operation .....	14
Condenser Fan Motors.....	14
Coils .....	14
Condenser Coil Protection .....	14
Heating Section .....	14
Gas Heat Design and Control Options.....	14
Staged Gas Heat.....	14
Electric.....	14
Air Management .....	15
Controls .....	15
Indoor Air Quality .....	15
Electrical.....	16
Service And Installation .....	16
<b>SECTION 2 – INSTALLATION</b> .....	<b>17</b>
Approvals .....	17
Limitations .....	17
Unit Inspection.....	17
Locations And Clearances.....	18
Rigging And Handling.....	19
Electrical Data .....	26
Electrical Service Sizing .....	26
Load Definitions.....	26
Filters.....	29
Condensate Drain .....	29
Condensate Drain Piping .....	29
Condensate Drain Trap .....	29
Air Hoods For Economizer .....	30
Air Hoods For Fixed Outside Air (Units Without Economizer) .....	30
Air Hoods For Exhaust Air .....	30
Field Wiring .....	30
Thermostat .....	30
Space Sensor.....	30
CO <sub>2</sub> Sensor .....	30
Occupied/Unoccupied Input .....	30
Shutdown Input .....	30
Smoke Purge Input.....	31
VAV Heat Relay Output.....	31

## TABLE OF CONTENTS (CONT'D)

Return Air Bypass Damper .....	31
Bacnet Communication .....	32
Dirty Filter Switch .....	32
Alarm Contacts.....	32
Electrical Service Sizing .....	35
Transducer Pneumatic Tubing.....	39
Static Pressure Control Plastic Tubing (Pneumatic Tubing).....	39
Duct Static Transducer .....	39
Building Pressure Transducer .....	39
Static Pressure Probe Installation .....	39
Roof Curb Installation.....	39
General Information.....	39
Duct System .....	40
Duct Connection Guidelines .....	40
Sound And Vibration Transmission.....	40
Gas Heating .....	41
Gas Piping.....	41
Gas Connection.....	41
Gas Piping Recommendations.....	41
Combustion Vent.....	42
<b>SECTION 3 – START-UP .....</b>	<b>43</b>
Crankcase Heaters.....	43
Checking The System Prior To Initial Start (No Power).....	43
Unit Checks .....	43
Unit Checks – Power Applied .....	45
Verifying Compressor Rotation.....	45
Compressor Oil Level Check.....	45
Initial Start-Up.....	46
Refrigerant Charge .....	46
Checking Superheat and Subcooling .....	46
Subcooling (R-410A).....	46
Superheat (R-410A) .....	48
Leak Checking.....	48
Gas Heat Models.....	48
Pre-Start Checks .....	48
Post Start Checks.....	49
Manifold Pressure – Modulating Gas .....	49
Manifold Gas Pressure Adjustment.....	50
<b>SECTION 4 – MAINTENANCE .....</b>	<b>51</b>
General.....	51
Periodic Maintenance – Monthly .....	51
Filters.....	51
Linkages .....	51
Compressors .....	51
Fan Bearing Lubrication .....	51
Recommended Lubricant for Fan Bearings.....	52
Condenser Coils.....	52

## TABLE OF CONTENTS (CONT'D)

Periodic Maintenance – Three To Six Months .....	52
Motor Bearing Lubrication .....	52
Belt Tension .....	52
Periodic Maintenance – Yearly .....	52
Entire Unit Inspection .....	52
Sheave Alignment .....	52
Belts .....	53
Belt Replacement .....	53
Filter Drier Replacement .....	54
Forward Curved Fans .....	54
Fan Motor .....	55
Fan Shaft Bearings .....	55
Mounting Details .....	55
Bearing Lock Devices .....	56
Eccentric Type .....	56
Torquing of Set-screws .....	57
<b>SECTION 5 – SEQUENCE OF OPERATION .....</b>	<b>59</b>
Unit Type .....	59
Current Oper Mode .....	59
Constant Volume Mode .....	59
Staged Input .....	60
Variable Air Volume Mode .....	60
Occupied Cooling .....	60
Occupied Heating .....	60
Unoccupied Cooling .....	60
Unoccupied Heating .....	60
Single Zone VAV Mode .....	61
Unit Mode Determination .....	61
Supply Air Temp Active Setpoint Determination .....	62
FlexSys .....	62
Active Setpoint Determination .....	62
Constant Volume .....	62
Staged Input Control .....	63
Variable Air Volume .....	63
Hardwired Sat Reset .....	64
Outside Air Based Sat Reset .....	64
Return Air Based Sat Reset .....	65
Supply Fan Speed Based Sat Reset .....	65
FlexSys with Bypass Damper .....	66
FlexSys without Bypass Damper .....	66
Compressor Control .....	66
Compressor Operation With Economizer .....	67
No Compressors On When Economizer Becomes Active .....	67
Compressor On When Economizer Becomes Active .....	67
Supply Fan Operation .....	67
Constant Volume Operation .....	67
Variable Air Volume (VAV) .....	68
VAV Supply Fan Speed Control .....	69
Setpoint Determination .....	69
Supply Fan Speed Determination .....	69

## TABLE OF CONTENTS (CONT'D)

Compressor Staging Sequence .....	70
Condenser Fan Operation .....	71
Low Ambient Condenser Fan Operation .....	71
Economizer .....	71
Dry Bulb .....	71
Single Enthalpy .....	72
Dual Enthalpy .....	72
Best Method .....	72
Nonflexsys Economizer .....	72
FlexSys Economizer .....	72
Compressor Operation .....	73
Fast Compressor Start .....	73
Compressor Data .....	73
Compressor Ready To Run .....	73
Compressor Ready To Stop .....	73
Compressor Safety Circuit .....	74
Low Pressure Cutout .....	75
Suction Temperature Monitoring .....	75
Supply Air Tempering .....	76
Modulating Gas Heat, Hot Water and Steam .....	76
Staged Gas or Electric Heat .....	76
Comfort Ventilation .....	77
System Pump Down Control .....	77
High Discharge Pressure Unloading .....	78
Low Ambient Lock Out .....	78
Low Ambient Fan Control Option .....	79
General .....	79
Operation and Pressure Control Range .....	79
Configuration (Jumpers and Potentiometers) .....	79
Flexsys Bypass Damper Operation .....	80
Evaporator Superheat Calculation .....	81
Staged Input Fault .....	81
Electric Heat .....	81
Programmed Data .....	81
Heating Control Offset .....	81
Active SP .....	82
Heating Control .....	82
Staged Gas Heat .....	82
Programmed Data .....	82
Heating Control Offset .....	83
Active SP .....	83
Heating Control .....	83
Staged Gas Heat Mode of Operation Status .....	84
Staged Gas Heat Ignition Sequence .....	84
Modulating Gas Heat .....	85
Overview .....	85
Programmed Data .....	86
Active SP .....	86
Heating Control Offset .....	86
Modulating Step Size .....	86
Modulating Gas Heat Mode of Operation Status .....	87



## TABLE OF CONTENTS (CONT'D)

Furnace Ignition Sequence .....	87
Hot Water/Steam Heat .....	88
Programmed Data .....	88
Active SP .....	89
Sequence of Operation .....	89
Freeze Protection .....	89
Freeze Fault .....	89
Morning Warm Up .....	89
Sequence of Operation .....	90
Adaptive Morning Warm Up .....	90
Sequence of Operation .....	91
Flexsys Under Floor Temperature Control.....	91
Under Floor Heating Sequence of Operation .....	92
Dew Point Reset Sequence of Operation.....	92
Exhaust Fan Operation .....	92
On/Off Control Based On Damper Position.....	92
On/Off Control Based On Building Pressure .....	92
Modulating Damper with Fixed Speed Exhaust .....	93
Modulating Exhaust with A VFD .....	93
VFD Exhaust Fan Control BAS .....	94
Return Fan Operation.....	94
VFD Return Fan without Exhaust.....	94
VFD Return Fan with Exhaust.....	94
VFD Return Fan with Exhaust BAS Control .....	95
Ventilation System .....	95
2-Position Damper .....	96
Demand Ventilation .....	96
Fixed Minimum .....	96
Tek-Air: Air Measuring Station .....	97
Required Program Values .....	97
TEK Air Full IAQ .....	99
Air Measurement Station Auto Zero .....	99
Air Measurement Station Field Adjustment .....	99
TEK Air Full IAQ Air Measurement Station .....	100
Smoke Purge.....	100
<b>SECTION 6 – USER INTERFACE CONTROL CENTER.....</b>	<b>101</b>
User Interface Control Center .....	101
Data Entry Keys .....	101
Navigation Keys .....	102
Menu Select Keys .....	102
Setpoints .....	115
Program.....	115
Options .....	115
Date / Time .....	115
Schedule .....	116
Operating Hours / Start Counter.....	117
Printer .....	118
Set Up .....	118
Report Section.....	118

## TABLE OF CONTENTS (CONT'D)

Service .....	119
History .....	128
Password.....	130
Power Up Banner .....	130
Communication .....	131
Communication Ports .....	131
BACnet Wiring.....	131
Device Object Instance (DE).....	131
Additional Settings.....	132
<b>SECTION 7 – PARAMETER DESCRIPTIONS AND OPTIONS .....</b>	<b>161</b>
<b>SECTION 8 – SERVICE.....</b>	<b>169</b>
Analog Input Operation .....	169
Temperature Sensors .....	169
Duct Pressure Transducer.....	169
Building Pressure Transducer .....	170
Return Fan Pressure Transducer .....	170
Discharge Pressure Transducer.....	171
Suction Pressure Transducer .....	171
Humidity Sensors .....	172
CO <sub>2</sub> Sensor .....	172
Furnace Status Input.....	172
Faults.....	174
Multi Media Card .....	183
Temperature .....	185

## LIST OF FIGURES

<b>FIGURE 1</b> - Packaged Rooftop Air Conditioning Unit .....	13
<b>FIGURE 2</b> - Double Sloped SS Drain Pan .....	15
<b>FIGURE 3</b> - Unit Clearances .....	18
<b>FIGURE 4</b> - Lifting Lug Locations.....	19
<b>FIGURE 5</b> - Drain Trap Showing Water Location During Draw Through Operation Stages.....	29
<b>FIGURE 6</b> - Trap Detail For Draw Through Application.....	29
<b>FIGURE 7</b> - Field Control Wiring - Inputs .....	33
<b>FIGURE 8</b> - Field Control Wiring - Outputs .....	34
<b>FIGURE 9</b> - Single-Point Power Supply Wiring .....	36
<b>FIGURE 10</b> - Single-Point Power Supply Wiring With Non-Fused Disconnect .....	37
<b>FIGURE 11</b> - Dual-Point Power Supply Wiring.....	38
<b>FIGURE 12</b> - Static Pressure Probe Location .....	40
<b>FIGURE 13</b> - Typical Gas Piping Connection.....	41
<b>FIGURE 14</b> - Combustion Vent .....	42
<b>FIGURE 15</b> - Fan Isolator Spring Bolts (Total Of 8).....	44
<b>FIGURE 16</b> - Manifold Gas Pressure Adjustment .....	50
<b>FIGURE 17</b> - Sheave Alignment.....	52
<b>FIGURE 18</b> - Fan Data Plate - Belt Tension .....	53
<b>FIGURE 19</b> - Belt Tensioning Gauge.....	53
<b>FIGURE 20</b> - Example Of FC Fan Shaft/Wheel Marking.....	54
<b>FIGURE 21</b> - Bearing With Setscrew Type Locking Device .....	56
<b>FIGURE 22</b> - Bearing With Eccentric Cam.....	56
<b>FIGURE 23</b> - Eccentric Cam Locking Collar Bearing Installation.....	57
<b>FIGURE 24</b> - Split Bearing .....	57
<b>FIGURE 25</b> - Operational Mode : Single Zone VAV .....	61
<b>FIGURE 26</b> - Active Sat Setpoint Vs. Supply Air Temp RST Voltage .....	64
<b>FIGURE 27</b> - Active Sat Setpoint Vs. Outside Air Temp .....	64
<b>FIGURE 28</b> - Factive Sat Setpoint Vs. Return Air Temp.....	65
<b>FIGURE 29</b> - Active Sat Setpoint Vs. Supply Fan Speed.....	65
<b>FIGURE 30</b> - Active DSP Setpoint Vs. Duct Static Pres RST Voltage .....	70
<b>FIGURE 31</b> - Condenser Fan VFD Potentiometer Settings .....	80
<b>FIGURE 32</b> - Modulating Gas Heat Staging Sequence.....	85
<b>FIGURE 33</b> - Sat Error .....	87
<b>FIGURE 34</b> - Active Return Plenum Pressure Setpoint Vs. Exhaust Output.....	95
<b>FIGURE 35</b> - Fixed Minimum Ventilation Control - OA Damper vs. Supply Fan VFD Speed.....	97
<b>FIGURE 36</b> - EK Air Full IAQ Flow Control.....	99
<b>FIGURE 37</b> - TEK Air Full IAQ Economizer.....	99
<b>FIGURE 38</b> - User Interface Control Panel .....	101
<b>FIGURE 39</b> - IPU Control Board.....	131
<b>FIGURE 40</b> - Mac Address Switches.....	131
<b>FIGURE 41</b> - I/O Control Board.....	175
<b>FIGURE 42</b> - I/O Control Board - Binary Outputs.....	176
<b>FIGURE 43</b> - I/O Control Board - Binary Inputs.....	177
<b>FIGURE 44</b> - I/O Control Board - Analog Outputs.....	177
<b>FIGURE 45</b> - I/O Control Board - Analog Inputs (See Table 50 For Pin Outs).....	177

## LIST OF TABLES

<b>TABLE 1</b> - Voltage Limitations .....	17
<b>TABLE 2</b> - Physical Data.....	20
<b>TABLE 3</b> - Electrical Data .....	27
<b>TABLE 4</b> - Airflow And Entering Air/Ambient Limitations.....	28
<b>TABLE 5</b> - Pipe Sizes.....	41
<b>TABLE 6</b> - R410-A Pressure / Temperature Chart .....	47
<b>TABLE 7</b> - Low Fire / High Fire Pressure - Staged .....	49
<b>TABLE 8</b> - Low Fire / High Fire Modulating.....	49
<b>TABLE 9</b> - Low Fire (Inducer Fan On Low, 1.4" W.C. Input To Maxitrol Valve).....	49
<b>TABLE 10</b> - High Fire (Inducer Fan On High, 3.5" W.C. Input To Maxitrol Valve).....	49
<b>TABLE 11</b> - Gas Heat Performance Data .....	50
<b>TABLE 12</b> - Fan Bearing – Lubrication Intervals .....	51
<b>TABLE 13</b> - Set Screw Torque .....	57
<b>TABLE 14</b> - Digital Inputs For Staged Input Staged Input Mode.....	60
<b>TABLE 15</b> - Active Sat Setpoint Determination, Zone Temperature.....	62
<b>TABLE 16</b> - Active Sat Setpoint Determination, Staged Input .....	63
<b>TABLE 17</b> - Supply Fan VFD Speed Determination .....	69
<b>TABLE 18</b> - 70-105 Ton Units .....	70
<b>TABLE 19</b> - Binary Outputs.....	79
<b>TABLE 20</b> - VFD Jumpers.....	79
<b>TABLE 21</b> - Potentiometer Settings .....	80
<b>TABLE 22</b> - CFM.....	82
<b>TABLE 23</b> - Heat Stages.....	82
<b>TABLE 24</b> - CFM.....	83
<b>TABLE 25</b> - Heat Stages.....	83
<b>TABLE 26</b> - Status .....	103
<b>TABLE 27</b> - Unit Data.....	104
<b>TABLE 28</b> - Cooling .....	105
<b>TABLE 29</b> - Compressor Systems (1, 2, Or 3).....	107
<b>TABLE 30</b> - Supply System.....	108
<b>TABLE 31</b> - Heating .....	109
<b>TABLE 32</b> - Economizer.....	112
<b>TABLE 33</b> - Ventilation .....	113
<b>TABLE 34</b> - exhaust.....	114
<b>TABLE 35</b> - Operating Hours / Start Counter .....	117
<b>TABLE 36</b> - Service.....	120
<b>TABLE 37</b> - BACnet MS/TP, MODBUS, BACnet IP .....	133
<b>TABLE 38</b> - Lon Points List.....	145
<b>TABLE 39</b> - N2 Points List .....	152
<b>TABLE 40</b> - Definitions.....	161
<b>TABLE 41</b> - Temperature Sensor Resistance .....	169
<b>TABLE 42</b> - Duct Pressure Transducer.....	170
<b>TABLE 43</b> - Building Pressure Transducer Output.....	170
<b>TABLE 44</b> - Return Fan Pressure Transducer Output .....	170
<b>TABLE 45</b> - Pressure Transducers .....	171
<b>TABLE 46</b> - Humidity Sensor Outputs.....	172
<b>TABLE 47</b> - CO <sub>2</sub> Sensor Output.....	172
<b>TABLE 48</b> - Furnace Status Input Modulating Gas Heat .....	173
<b>TABLE 49</b> - Furnace Status Input Staged Gas Heat.....	173
<b>TABLE 50</b> - I/O Control Board - Analog Input Pin Outs.....	178
<b>TABLE 51</b> - Warning Description Table.....	179
<b>TABLE 52</b> - Fault Auto - Reset.....	181
<b>TABLE 53</b> - Faults Lockout .....	182
<b>TABLE 54</b> - Data Log Error State.....	184
<b>TABLE 55</b> - Data Log Error Log Detail.....	184
<b>TABLE 56</b> - SI Metric Conversion .....	185

## SECTION 1 – INTRODUCTION

### ECOLOGICAL AND ECONOMICAL DESIGN

First packaged RTU with R410A optimized design.

#### Cooling and Heating

Superior operating performance provides lower operating costs. Smaller steps of cooling capacity provide tighter control of building environment and occupant comfort while optimizing energy efficiency.

#### Indoor Air Quality (IAQ)

Outside air economizers provide energy savings in free cooling mode, and can provide a healthier and more comfortable building environment by introducing fresh outside air into the building as needed. Indoor Air Quality (IAQ) requirements for building ventilation and comfort are controlled through the microprocessor control panel. Optional airflow measurement provides an accurate means of tracking air quality and alerting the occupants or building owner to unhealthy situations.

#### High-Efficiency Motors

High-efficiency motors are available for optimum energy efficiency. All motors used on the YPAL packaged rooftop air conditioner meet U.S. EPACK 1992 minimum requirements.

#### Modulating Gas Heat

Fully modulating gas heat and greater steps of capacity control offer superior off-design performance while maintaining optimum occupant comfort.

### CONDENSING SECTION

#### Scroll Compressors

Reliable, efficient, trouble-free operation is the true measure of a packaged rooftop's value. That's why YORK YPAL Packaged Rooftop Air Conditioners use established scroll-compressor technology to deliver dependable, economical performance in a wide range of applications. With the YPAL Packaged Rooftop, you get the latest generation of compressor enhancements added to the scroll's inherent strengths. The simplicity of a hermetic scroll compressor allows the use of fewer moving parts to minimize breakdown.

#### Multiple Compressor Staging

Through the use of the scroll compressor, the YPAL has the ability to stage its cooling by enabling and disabling multiple single stage compressors on multiple circuits. These compressors are manifolded together in three independent circuits.



00406vip

**FIGURE 1 - PACKAGED ROOFTOP AIR CONDITIONING UNIT**

## Compressor Circuiting

The YPAL is designed so that only two scroll compressors are in tandem within one refrigeration circuit. This means more reliable compressors, and less equipment down time. With multiple circuits, if a compressor should ever fail on one circuit, the other circuit/s will remain operational to work to maintain occupied loads. The YPAL system has two or three circuits in the unit depending on the size.

## Compressor Sound Blankets

Optional factory installed sound blankets can be installed to further reduce compressor sound attenuation.

## Replaceable Core Filter Driers

The optional replaceable core filter driers on the YPAL provide a convenient means for maintaining and optimizing the unit's refrigeration system. Eliminating additional field penetrations into the refrigerant circuit, which could lead to potential problems, reduce the worry of refrigerant circuit contamination.

## Low Ambient Operation

Head-pressure control is accomplished via a VFD motor controller rather than an inefficient and noisy condenser fan damper. By varying the speed of the condenser fan, better control and quieter operation is obtained during the colder months. Low ambient controls are available on all systems offering higher rooftop cooling capacity than competitive units.

## Condenser Fan Motors

The condenser fan motors used on the YPAL unit are Totally Enclosed Air Over (TEAO) to provide maximum durability through any season.

## Coils

Condenser coils are microchannel type and made of a single material to avoid galvanic corrosion due to dissimilar metals. Coils and headers are brazed as one piece. Integral sub cooling is included. The design working pressure of the coil is 650 PSIG (45 bar).

## Condenser Coil Protection

The YPAL is available with either a wire mesh covering or louvered panels for optimum coil protection. In applications where unauthorized personnel may have access to the units, or the units may be susceptible to severe weather conditions such as hail, the louvered panel provides protection around the entire condensing section giving the maximum protection to the coils and refrigerant components.

## HEATING SECTION

### Gas Heat Design and Control Options

Include an unsurpassed 24:1 turndown modulating gas furnace, and staged heating control. A Staged furnace is also available that allows up to six stages of capacity.

### Staged Gas Heat

The YPAL rooftop gas furnace is an induced-draft gas furnace designed for high efficiency and reliability. The furnace uses an aluminized steel tubular heat exchanger and operates at temperatures sufficient to prevent acidic exhaust gases from condensing in the heat exchanger at low fire rates, unlike drum and tube style furnaces that generate condensation formation.

### Electric

The YPAL is also available with an electrical heater that can range from 40kW up to 250kW. Depending on the size of the heat required, the YPAL can have three to six steps of control helping to provide tighter control of the supply and zone conditioned air. With the utilization of this multi step function, the YPAL can effectively reduce energy consumption by bringing on smaller stages of heat while maintaining the maximum level of comfort.

## AIR MANAGEMENT

The YORK FlexSys Underfloor Air system provides a cutting edge, cost competitive alternative to conventional overhead air distribution systems based on the performance and system flexibility benefits that it can provide. When combined with a YORK YPAL Packaged Rooftop Unit, the system offers a completed package that provides an optimum solution for building comfort control.

FlexSys technology uses the open space between the structural concrete slab and the underside of a raised access floor system to deliver conditioned air directly into the occupied zones of office and other commercial buildings. This underfloor plenum incorporates the air distribution system with the building power, telecom, and data cabling in one easily accessed service plenum.

The raised access floor concept is a proven design ideal for office buildings that house today’s modern business that relies on critical information technologies to maintain high productivity levels. The unmatched flexibility offered by raised floor systems allows for significant costs savings and reduced downtimes when a fast-paced economy demands office space reconfiguration.

- **dDWDI Airfoil Fans** – High efficiency fans are used to improve application flexibility, and address sound and application concerns.
- **Building pressure control** – Return fans, exhaust fans, and barometric relief dampers are available to meet building pressure control requirements. Select the most appropriate option for a given application.
- **Low sound options** – allow for application of the YPAL unit in sound-sensitive applications such as theaters and downtown areas. Contact Johnson Controls for more details on site-specific requirements.
- **Variable Frequency Drives** – when a VAV unit is ordered, the YPAL comes standard with variable frequency drives (VFD’s). The VFD can optimize a systems performance by modulating the supply fan motor speed to reduce energy consumption by as much as 40% while maximizing occupant comfort.
- **Fan Spring Isolation** – Two-inch spring isolation is used to prevent vibration transmission from the rooftop unit’s supply fan to the building.

## CONTROLS

- **Rooftop Controller** – the ColdFire™ processor-based controller uses the latest in processor technology to provide the highest level of rooftop control with BACnet open protocol communication capabilities. An 80-character display and keypad are standard for simple, and easy to understand manipulation of control setpoints and readout of operating parameters and diagnostics. Shutdown and alarm faults are all recorded in memory, and include a time and day stamp for easy troubleshooting.
- **BACnet** – the YPAL can be adapted to operate with any building automation system that is BACnet compatible making it the most flexible large commercial rooftop units on the market.

## INDOOR AIR QUALITY

- **Double Sloped Stainless Steel Drain Pan** – the YPAL’s standard Stainless Steel drain pan meets ASHRAE 62 requirements for condensate drainage to improve indoor air quality. Solid wall liners encase insulation and prevent moisture from damage. Additional benefits include easy cleanability and isolates insulation from conditioned airstream.

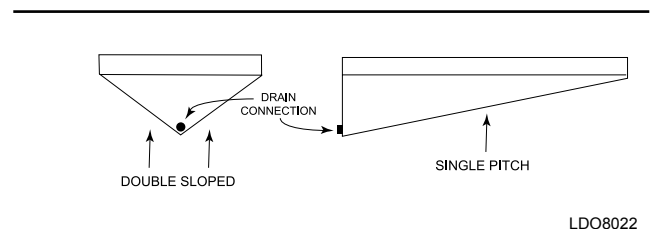

**FIGURE 2 - DOUBLE SLOPED SS DRAIN PAN**

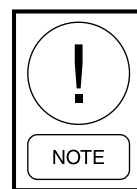

*This is a visual reference only. Actual drain pan pitch will vary.*

- **Double Wall Construction** – is the standard construction of the YPAL and incorporates powder coated pre-fabricated outer panels and corner post for maximum exterior surface protection.

- **Factory Shrinkwrap** – all YPAL rooftop units can be ordered from the factory with an optional factory-fresh shrinkwrap packaging. This eliminates the contractor's worries about dirt and debris clogging up condenser coils or moisture leaking into the air handler on the units way to the job site or rigging yard.
- **Demand Ventilation** – can be incorporated into the unit to improve indoor air quality and help manage indoor pollutants such as CO<sub>2</sub> or other harmful airborne contaminants out of the occupied spaces for maximum comfort and safety. Activation of this sequence can easily be accomplished using CO<sub>2</sub> sensors connected to the unit. The rooftop unit controller includes two analog inputs for sensors to sense indoor and/or outdoor CO<sub>2</sub> levels to maintain optimum occupant comfort and safety. CO<sub>2</sub> sensors are typically used with demand ventilation; however other sensors may be applied to control indoor contaminants such as volatile organic compounds (VOCs).
- **Smoke Purge** – is also available through the User Interface to evacuate smoke due to fire from a room or zone.
- **Filtration** – The YPAL is configured for various types of filtration to meet the different needs and requirements of today's rooftop applications, including 2-inch throwaway, pleated, carbon, and cleanable filters and 12-inch high efficiency rigid filters.

## ELECTRICAL

- **Single Point Power** – The YPAL unit comes standard with single point power connections to make installation quick and easy.
- **Dual Point Power** – can be factory installed for applications that require the mechanical heating and cooling functions to be separated from the air handling functions. This enables the unit to be operated in an emergency condition while minimizing power consumption.
- **Unit-Mounted Disconnect** – is available as an option to minimize time at installation of equipment and to reduce necessary field installed items.

## SERVICE AND INSTALLATION

- **Access Doors** – Full-sized access doors provide easy access into the unit for routine maintenance and inspection.
- **Service Valves** – Oversized service valves to provide isolation and quick reclamation and charging of system refrigerant are available to minimize downtime and simplify the service and repair task.
- **Convenience Outlet** – For maintenance tasks requiring power tools, an optional 110V GFCI power supply can power lights, drills or any other power hand tool needed.
- **Factory Run-Tested** – Each unit is subjected to a series of quality assurance checks as well as an automated quality control process before being run-tested. Fans and drives are balanced at the factory during testing. The factory run-test ensures safe proper operation when the unit is installed, and reduces installation and commissioning time.
- Replaceable core filter drier option provides a means to remove moisture, dirt and debris from the refrigeration circuit in the event it is opened.



## SECTION 2 – INSTALLATION

### APPROVALS

Designed certified by ETL and CETL as follows:

1. For use as a forced air furnace with cooling unit (gas heat models).
2. For outdoor installation only.
3. For installation on combustible material and may be installed directly on combustible flooring or Class A, Class B or Class C roof covering materials.
4. For use with natural gas or LP.
5. When used with LP propane gas one of the following conversion kits must be installed before the gas heat section is fired:
  6. 375,000 BTU Input - 385-01866-001
  7. 750,000 BTU Input - 385-01866-002
  8. 1,125,000 BTU Input - 385-01866-003

Not suitable for use with conventional venting systems.

### LIMITATIONS

The installation of this unit must conform to local building codes, or in the absence of local codes, with ANSI Z23.1 Natural Fuel Gas Code and /or CAN/CGA B149 installation codes.

In U.S.A.:

1. National Electrical Code ANSI/NFPA No. 70 - Latest Edition.
2. National Fuel Gas Code Z223.1 - Latest Edition.

**TABLE 1 - VOLTAGE LIMITATIONS**

NOMINAL VOLTAGE	UNIT POWER SUPPLY	VOLTAGE VARIATIONS	
		MIN. VOLTS	MAX. VOLTS
600	575-3-60	540	630
480	480-3-60	432	504
240	230-3-60	216	252
208	200-3-60	182	218

3. Gas-Fired Central Furnace Standard ANSI Z21.47 - Latest Edition.
4. Local gas utility requirements.

Refer to *Table 4 on page 28* for airflow and entering air/ambient conditions limitations, and *Table 1 on page 17* for voltage limitations.



***If the VAV boxes in the conditioned space have hydronic heating coils installed, it is the responsibility of the installing contractor to take appropriate measures to protect the hydronic coils against low unit supply air temperatures that could result in the freeze up and rupture of the coils.***

### UNIT INSPECTION

Immediately upon receiving the unit, it should be inspected for possible damage, which may have occurred during transit. If damage is evident, it should be noted in the carrier's freight bill. A written request for inspection by the carrier's agent should be made at once. See *Shipping Damage Claims (Form 50.15-NM)* for more information and details.



***To ensure warranty coverage, this equipment must be commissioned and serviced by an authorized Johnson Controls service mechanic or a qualified service person experienced in packaged rooftop installation. Installation must comply with all applicable codes, particularly in regard to electrical wiring and other safety elements such as relief valves, HP cut-out settings, design working pressures, and ventilation requirements consistent with the amount and type of refrigerant charge.***

***Lethal voltages exist within the control panels. Before servicing, open and tag all disconnect switches.***

**LOCATIONS AND CLEARANCES**

The following guidelines should be used to select a suitable location for unit installation.

1. Unit is designed for outdoor installation only.
2. Condenser coils must have an unlimited supply of air. Where a choice of location is possible, position the unit on either north or east side of building.
3. Suitable for roof mount on curb.
4. Roof structures must be able to support the weight of the unit and its accessories. Unit must be installed on a solid level roof curb or appropriate angle iron frame.
5. Maintain level tolerance to 1/2 inch across width and 2 inches along the length.

Unit clearances are shown in *Figure 3 on page 18*.

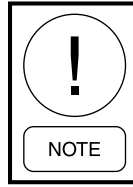

*The clearances shown are to provide adequate condenser airflow and service access to inside the unit. Additional clearance should be considered for component replacement such as compressors, evaporator coils, and supply or exhaust fans.*

*While it is a common practice to operate the fan as soon as possible (air movement during construction) on the job site, the incomplete ductwork and missing diffuser grilles will greatly reduce air resistance and will allow the fan to operate beyond design parameters. This practice may result in water carry over and flooding of the unit. Also, the supply fan motor may overamp and become damaged.*

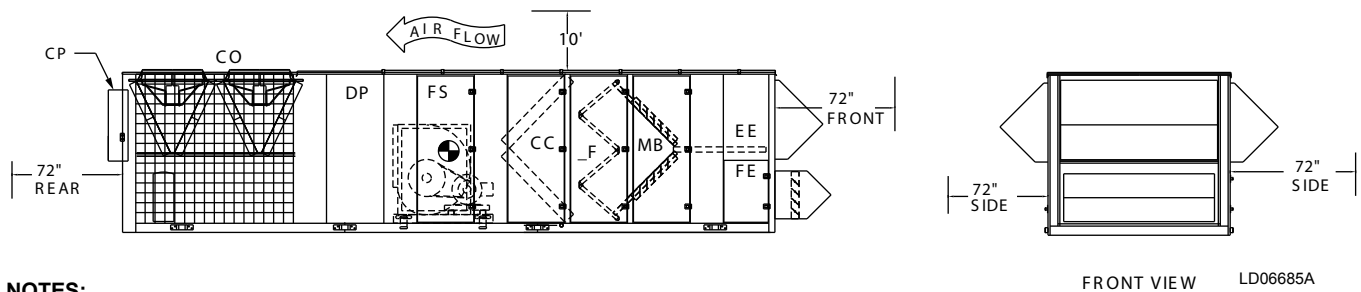

**NOTES:**

1. Ten foot clearance minimal over the top of the condensing unit.
2. Only one adjacent wall can exceed unit height.
3. Twelve foot clearance required to adjacent units.
4. Eight foot service access recommended on one side.
5. Economizer and exhaust hoods, where applicable, are folded inside unit for shipment.
6. Dim. is to outside of lifting lugs.

**FIGURE 3 - UNIT CLEARANCES**

### RIGGING AND HANDLING

Proper rigging and handling of the equipment is mandatory during unloading and setting it into position to retain warranty status. All lifting lugs must be used to prevent twisting and damage to the unit.

Care must be taken to keep the unit in the upright position during rigging and to prevent damage to the water-tight seams in the unit casing. Avoid unnecessary jarring or rough handling.

See *Figure 4 on page 19* for number and location of the lifting lugs by unit size. It is also mandatory that an experienced and reliable rigger be selected to handle

unloading and final placement of the equipment. The rigger must be advised that the unit contains internal components and that it be handled in an upright position. Care must be exercised to avoid twisting the equipment structure.

Unit weights are listed under *Table 2 on page 20* in this manual. These weights must be referred to when selecting a crane for rigging and figuring roof weight loads. Contact your Johnson Controls Sales Office if you have any questions regarding unit weights.

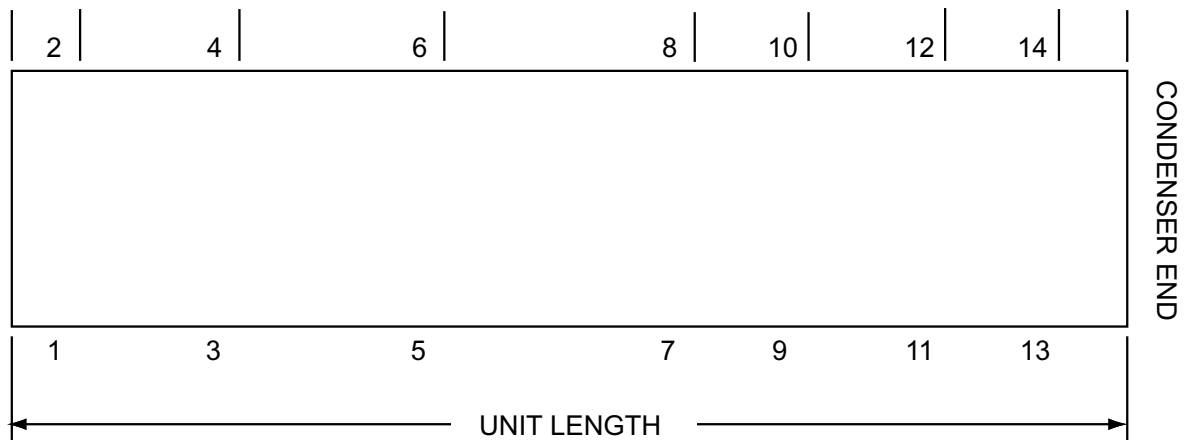

UNIT SIZE	TONS	UNIT LENGTH INCHES	DIMENSION						
			1-2	3-4	5-6	7-8	9-10	11-12	13-14
70 - 80 STD Cabinet		454	30.13	77.25	197.25	271.00	319.25	374.25	429.38
90 - 106 STD Cabinet		488	30.13	99.25	190.25	302.50	353.13	408.00	463.13
70 - 80 EXTD Cabinet		517	30.13	77.25	197.25	271.00	382.25	437.25	492.39
90 - 105 EXTD Cabinet		517	30.13	99.25	190.25	302.50	422.12	477.25	532.13

**FIGURE 4 - LIFTING LUG LOCATIONS**

TABLE 2 - PHYSICAL DATA

## 70 TON MODELS

MODEL SIZE	070
<b>General Data</b>	
Standard cabinet length without hoods (inches)	454
Extended cabinet length without hoods (inches)	517
Width (Inches)	92
Height (Inches)	92
<b>Weights (Lbs.) (base unit, no option)</b>	
Base cabinet, cooling only with economizer	11,817
Extended cabinet, cooling only with economizer	13,027
<b>Option Weights (Lbs.)</b>	
Power Exhaust (Blower, mtr, mtr base, fan skid, mod damper & hood)	1045
Power Exhaust (Blower, mtr, mtr base, fan skid, VFD, baro damper & hood)	1044
100% AMS (Measurement Station & Mounting)	125
25/75% AMS (Measurement Station & Mounting)	146
Min. AMS (Measurement Station & Mounting)	45
Barometric only	45
375 MBH Gas Heat	162
750 MBH Gas Heat	324
1125 MBH Gas Heat	486
40 kW/480/3/60 2 Steps Electric Heat	NA
80 kW/208/3/60 or 108 kW/240/3/60 6 Steps Electric Heat	NA
108 kW/480/3/60 3 steps Electric Heat	470
150 kW/480/3/60 4 Steps Electric Heat	490
200 kW/480/3/60 6 Steps Electric Heat	510
250 kW/480/3/60 7 Steps Electric Heat	530
Condenser Wire Guard	40
Copper Condenser Coils (additional)	617
Copper Evaporator Coils (additional)	280
Hot Water Coil	318
Steam Heating Coil	236
Diffuser <sup>3</sup>	53
Final filters <sup>3</sup>	535
Final filters, racks only <sup>3</sup>	297
<b>Roof Curb Weights (Lbs.)</b>	
14" Full Perimeter Roof Curb	1,020
14" Open Condenser Roof Curb	577
<b>Compressor Data</b>	
Quantity/Size (Nominal HP)	4x10, 2x13
Type	Scroll
Capacity Steps (Qty x %)	4x15, 2x20

MODEL SIZE	070
<b>Refrigerant Charge (R410A STD Cabinet) *</b>	
SYS 1 - LB (KG)	36
SYS 2 - LB (KG)	31
SYS 3 - LB (KG)	31
<b>Refrigerant Charge (R410A EXTD Cabinet) *</b>	
SYS 1 - LB (KG)	38.4
SYS 2 - LB (KG)	33.4
SYS 3 - LB (KG)	33.4

\* Always verify proper charge values using the charge information printed on the rating plate on the unit

<b>Supply Fan and Drive</b>	
Quantity	1
Type	FC
Size	28-25
Motor Size Range (min. to max. HP)	7.5-50
Air Flow Range (min. to max. CFM)	14000-32000
Static Pressure Range (min. to max. ESP)	0-4"
<b>Optional Airfoil Supply Fan</b>	
Quantity	1 / 1
Type	AF
Size	32
Motor Size Range (min. to max. HP)	7.5-50
Air Flow Range (min. to max. CFM)	14s000-32000
Static Pressure Range (min. to max. ESP)	0-6"
<b>Exhaust Fan</b>	
Quantity	2
Type	FC
Size	18-18
Motor Size Range (min. to max. HP)	5-20
Air Flow Range (min. to max. CFM)	0-27000
Static Pressure Range (min. to max. ESP)	0-1"
<b>Optional Exhaust Fan</b>	
Quantity Fans/Motors	2 / 1
Type	FC
Size	20-18
Motor Size Range (min. to max. HP)	5-30
Airflow Range (min. to max. CFM)	0-32000
Static pressure range (min. to max., IWG)	0-2"
<b>Optional Return Fan</b>	
Quantity Fans/Motors	2 / 2
Type	Plenum
Size	270
Motor Size Range (min. to max. HP)	5-30
Airflow Range (min. to max. CFM)	0-32000
Static pressure range (min. to max., IWG)	0-3"

**TABLE 2 - PHYSICAL DATA (CONT'D)**

**70 TON MODELS**

MODEL SIZE	070
<b>Evaporator Coil</b>	
Size (square feet)	56.9
Number of rows / fins per inch	31/17
Tube Diameter / Enhanced Surface	3/8"
<b>Model Size Condenser Coil (R410A Microchannel)</b>	
Size (square feet)	162.2
Number of rows / fins per inch	1/21
Diameter	1 mm
Number of channels	18
<b>Condenser Fans</b>	
Quantity	6
Type	Prop.
Diameter (inches)	36
Power (hp each)	2
<b>Filters - 2" Throwaway (Pre-Filter Position)</b>	
Quantity	10 / 15
Size (length x width) (in.)	25X16 / 25x20
Total Filter Face Area (square feet)	77.1
<b>Filters - 2" Cleanable (Pre-Filter Position)</b>	
Quantity	10 / 15
Size (length x width) (in.)	25X16 / 25x20
Total Filter Face Area (square feet)	77.1
<b>Filters - 2" Pleated, 30% Efficient (Pre-Filter Position)</b>	
Quantity	10 / 15
Size (length x width) (in.)	25X16 / 25x20
Total Filter Face Area (square feet)	77.1
<b>Filters -12" Rigid 65%, 2" 30% Prefilter (Pre-Filter Position)</b>	
Quantity	2 / 8 / 9
Size (length x width) (in.)	16x20/25x 16/25x20
Total Filter Face Area (square feet)	55.8
<b>Filters -12" Rigid 95%, 2" 30% Prefilter (Pre-Filter Position)</b>	
Quantity	2 / 8 / 9
Size (length x width) (in.)	16x20/25x 16/25x20
Total Filter Face Area (square feet)	55.8

MODEL SIZE	070
<b>Filters - 2" Carbon (Pre-Filter Position)</b>	
Quantity	10 / 15
Size (length x width) (in.)	25X16 / 25x20
Total Filter Face Area (square feet)	77.1
<b>Filters - 12" rigid 95% in Post-filter Position</b>	
Quantity	2 / 7 / 9
Size (length x width) (in.)	16x20/25x 16/25x20
Total Filter Face Area (square feet)	55.1
<b>Gas Furnace</b>	
Staged Furnace Sizes (input/output/stages)	375 mbh / 300 mbh / 2 stages
	750 mbh / 600 mbh / 4 stages
	1125 mbh / 900 mbh / 6 stages
Inlet Gas Pressure Range (min. to max. IWG)	4.5 - 13.5" w.c.
Airflow Range (min. to max. CFM)	6,950-36,000
Modulating Furnace Sizes (input/output/turndown)	375 mbh / 300 mbh / 8:1 turndown
	750 mbh / 600 mbh / 16:1 turndown
	1125 mbh / 900 mbh / 24:1 turndown
Inlet Gas Pressure Range (min. to max. IWG)	4.5 - 13.5" w.c.
Minimum Heat Exchanger Entering Supply Air Temperature	40.0 °F
Airflow Range (min. to max. CFM)	8,250-36,000
<b>Electric Heaters</b>	
Size Range (min. to max. kW)	80-200
Heating Steps <sup>1</sup>	2-7
<b>Minimum Outside Air Temp. For Mech. Cig.</b>	45
<b>Low Ambient Option Min. Outside Air Temp</b>	0

1. Electric heat steps and airflow range depends on voltage and size. Consult the air pressure drop tables for specific number of steps for a given voltage.
3. Weights are for components only and need to be added to the extended cabinet weights. The diffuser is required in the extended cabinet for any unit with hot water or final filter option.

**TABLE 2 - PHYSICAL DATA (CONT'D)****75 - 105 TON MODELS**

<b>MODEL SIZE</b>	<b>075</b>	<b>080</b>	<b>090</b>	<b>105</b>
<b>General Data</b>				
Standard cabinet length without hoods (inches)	454	454	488	488
Extended cabinet length without hoods (inches)	517	517	557	557
Width (Inches)	92	92	92	92
Height (Inches)	92	92	92	92
<b>Weights (Lbs.) (base unit, no option)</b>				
Base cabinet, cooling only with economizer	11,880	12,066	12,171	12,391
Extended cabinet, cooling only with economizer	13,090	13,276	13,467	14,687
<b>Option Weights (Lbs.)</b>				
Power Exhaust (Blower, mtr, mtr base, fan skid, mod damper & hood)	1045	1045	1074	1074
Power Exhaust (Blower, mtr, mtr base, fan skid, VFD,baro damper & hood)	1044	1044	1068	1068
100% AMS (Measurement Station & Mounting)	125	125	140	140
25/75% AMS (Measurement Station & Mounting)	146	146	162	162
Min. AMS (Measurement Station & Mounting)	45	45	50	50
Barometric only	45	45	55	55
375 MBH Gas Heat	162	162	162	162
750 MBH Gas Heat	324	324	324	324
1050 MBH Gas Heat	486	486	486	486
40 kW/415/3/60 or 40 kW/480/3/60 2 Steps Electric Heat	NA	NA	NA	NA
80 kW/208/3/60 or 108 kW/240/3/60 5 Steps Electric Heat	510	510	NA	NA
108 kW/415/3/60 4 steps Electric Heat	470	470	510	510
150 kW/415/3/60 5 Steps Electric Heat	490	490	530	530
200 kW/415/3/60 or 200 kW/480/3/60 6 Steps Electric Heat	510	510	550	550
250 kW/480/3/60 7 Steps Electric Heat	NA	NA	570	570
Condenser Wire Guard	40	40	45	45
Copper Condenser Coils (additional)	617	1,058	1,190	1,190
Copper Evaporator Coils (additional)	460	280	460	580
Hot water coil	318	318	318	318
Steam heating coil	236	236	236	236
Diffuser3	53	53	53	53
Final filters3	535	535	565	565
Final filters, racks only3	297	297	327	327

**TABLE 2 - PHYSICAL DATA (CONT'D)**

**75 - 105 TON MODELS**

<b>MODEL SIZE</b>	<b>075</b>	<b>080</b>	<b>090</b>	<b>105</b>
<b>Roof Curb Weights (Lbs.)</b>				
14" Full Perimeter Roof Curb	1,020	1,020	1,040	1,040
14" Open Condenser Roof Curb	577	577	615	615
<b>Compressor Data</b>				
Quantity/Size (Nominal HP)	4x11, 2x13	4x13, 2x11	2x13, 4x15	4x20, 2x15
Type	Scroll	Scroll	Scroll	Scroll
Capacity Steps (Qty x %)	4x15, 2x20	4x18, 2x14	4x18, 2x14	4x18, 2x14
<b>Refrigerant Charge (R410a STD Cabinet)</b>				
SYS 1 - LB (KG)	34.5	29.9	33.3	36.1
SYS 2 - LB (KG)	24.3	21.1	23.5	25.9
SYS 3 - LB (KG)	24.3	24.3	23.5	25.5
<b>Refrigerant Charge (R410a EXTD Cabinet)</b>				
SYS 1 - LB (KG)	36.9	32.3	35.7	38.5
SYS 2 - LB (KG)	26.7	23.5	25.9	28.3
SYS 3 - LB (KG)	26.7	26.7	25.9	27.9
<b>Supply Fan and Drive</b>				
Quantity	1	1	1	1
Type	FC	FC	FC	FC
Size	28-25	28-25	28-28	28-28
Motor Size Range (min. to max. HP)	7.5-50	7.5-50	7.5-60	7.5-60
Air Flow Range (min. to max. cfm)	14000-32000	14000-32000	18000-36000	18000-36000
Static Pressure Range (min. to max. ESP)	0-4"	0-4"	0-4"	0-4"
<b>Optional Airfoil Supply Fan</b>				
Quantity	1 / 1	1 / 1	1 / 1	1 / 1
Type	AF	AF	AF	AF
Size	32	32	32	32
Motor Size Range (min. to max. HP)	7.5-50	7.5-50	7.5-60	7.5-60
Air Flow Range (min. to max. cfm)	14000-32000	14000-32000	18000-36000	18000-36000
Static Pressure Range (min. to max. ESP)	0-6"	0-6"	0-6"	0-6"
<b>Exhaust Fan</b>				
Quantity	2	2	2	2
Type	FC	FC	FC	FC
Size	18-18	18-18	18-18	18-18
Motor Size Range (min. to max. HP)	5-20	5-20	5-20	5-20
Air Flow Range (min. to max. cfm)	0-20000	0-20000	0-20000	0-27000
Static Pressure Range (min. to max. ESP)	0-1"	0-1"	0-1"	0-1"

**2**

**TABLE 2 - PHYSICAL DATA (CONT'D)****75 - 105 TON MODELS**

<b>MODEL SIZE</b>	<b>075</b>	<b>080</b>	<b>090</b>	<b>105</b>
<b>Optional Exhaust Fan</b>				
Quantity Fans/Motors	2 / 1	2 / 1	2 / 1	2 / 1
Type	FC	FC	FC	FC
Size	20-18	20-18	20-18	20-18
Motor Size Range (min. to max. HP)	5-30	5-30	5-30	5-30
Airflow Range (min. to max. CFM)	0-32000	0-32000	0-36000	0-36000
Static pressure range (min. to max., IWG)	0-2"	0-2"	0-2"	0-2"
<b>Optional Return Fan</b>				
Quantity Fans/Motors	2 / 2	2 / 2	2 / 2	2 / 2
Type	Plenum	Plenum	Plenum	Plenum
Size	270	270	270	270
Motor Size Range (min. to max. HP)	5-30	5-30	5-40	5-40
Airflow Range (min. to max. CFM)	0-32000	0-32000	0-36000	0-36000
Static pressure range (min. to max., IWG)	0-3"	0-3"	0-3"	0-3"
<b>Model Size</b>				
<b>Evaporator Coil R410A</b>				
Size (square feet)	56.9	56.9	56.9	56.9
Number of rows/fins per inch	3/17	3/17	3/17	3/17
Tube Diameter (enhanced tubes)	3/8"	3/8"	3/8"	3/8"
<b>Model Size</b>				
<b>Condenser Coil (R410A Microchannel)</b>				
Size (square feet)	162.2	162.2	162.2	162.2
Number of rows/fins per inch	1/21	1/21	1/21	1/21
Diameter	1 mm	1 mm	1 mm	1 mm
Number of channels	18	18	18	18
<b>Condenser Fans</b>				
Quantity	6	6	6	6
Type	Prop.	Prop.	Prop.	Prop.
Diameter (inches)	36	36	36	36
Power (hp each)	2	2	2	2
<b>Filters - 2" Throwaway (Pre-Filter Position)</b>				
Quantity	10 / 15	10 / 15	12 / 18	12 / 18
Size (length x width) (in.)	25X16 / 25x20	25X16 / 25x20	25X16 / 25x20	25X16 / 25x20
Total Filter Face Area (square feet)	77.1	77.1	92.5	92.5
<b>Filters - 2" Cleanable (Pre-Filter Position)</b>				
Quantity	10 / 15	10 / 15	12 / 18	12 / 18
Size (length x width) (in.)	25X16 / 25x20	25X16 / 25x20	25X16 / 25x20	25X16 / 25x20
Total Filter Face Area (square feet)	77.1	77.1	92.5	92.5
<b>Filters - 2" Pleated, 30% Efficient (Pre-Filter Position)</b>				
Quantity	10 / 15	10 / 15	12 / 18	12 / 18
Size (length x width) (in.)	25X16 / 25x20	25X16 / 25x20	25X16 / 25x20	25X16 / 25x20
Total Filter Face Area (square feet)	77.1	77.1	92.5	92.5



**TABLE 2 - PHYSICAL DATA (CONT'D)**

**75 - 105 TON MODELS**

MODEL SIZE	075	080	090	105
<b>Filters -12" Rigid 65%, 2" 30% Prefilter (Pre-Filter Position)</b>				
Quantity	2 / 8 / 9	2 / 8 / 9	8 / 12	8 / 12
Size (length x width) (in.)	16x20/25x16/25x20	16x20/25x16/25x20	25x16/25x20	25x16/25x20
Total Filter Face Area (square feet)	55.8	55.8	61.6	61.6
<b>Filters -12" Rigid 95%, 2" 30% Prefilter (Pre-Filter Position)</b>				
Quantity	2 / 8 / 9	2 / 8 / 9	8 / 12	8 / 12
Size (length x width) (in.)	16x20/25x16/25x20	16x20/25x16/25x20	25x16/25x20	25x16/25x20
Total Filter Face Area (square feet)	55.8	55.8	61.6	61.6
<b>Filters - 2" Carbon (Pre-Filter Position)</b>				
Quantity	10 / 15	10 / 15	12 / 18	12 / 18
Size (length x width) (in.)	25X16 / 25x20	25X16 / 25x20	25X16 / 25x20	25X16 / 25x20
Total Filter Face Area (square feet)	77.1	77.1	92.5	92.5
<b>Filters - 12" Rigid 95% In Post-Filter Position</b>				
Quantity	2 / 7 / 9	2 / 7 / 9	7 / 12	7 / 12
Size (length x width) (in.)	16x20/25x16/25x20	16x20/25x16/25x20	25x16/25x20	25x16/25x20
Total Filter Face Area (square feet)	55.1	55.1	61.1	61.1
<b>Gas Furnace</b>				
Staged Furnace Sizes (input/output/stages)	375 mbh / 300 mbh / 2 stages			
	750 mbh / 600 mbh / 4 stages			
	1125 mbh / 900 mbh / 6 stages			
Inlet Gas Pressure Range (min. to max. iwg)	4.5 - 13.5" w.c.			
Minimum Air ON Temperature	The Heat Exchanger 40 °F			
Airflow Range (min. to max. cfm)	6,950-36,000	11,150-36,000	15,150-36,000	
Modulating Furnace Sizes (input/output/turndown)	375 mbh / 300 mbh / 8:1 turndown			
	750 mbh / 600 mbh / 16:1 turndown			
	1125 mbh / 900 mbh / 24:1 turndown			
Inlet Gas Pressure Range (min. to max. IWG)	4.5 - 13.5" w.c.			
Minimum Heat Exchanger Entering Supply Air Temperature	40 °F			
Airflow Range (min. to max. cfm)	8,250-36,000	11,150-36,000	15,150-36,000	
<b>Electric Heaters</b>				
Size Range (min. to max. kW)	80-200	80-200	108-250	108-250
Heating steps1	2-7	2-7	2-7	2-8
Minimum Outside Air Temp. for Mech. Cig.	45	45	45	45
Low Ambient Option Min. Outside Air Temp	0	0	0	0

1. Electric heat steps and airflow range depends on voltage and size. Consult the air pressure drop tables for specific number of steps for a given voltage.
3. Weights are for components only and need to be added to the extended cabinet weights. The diffuser is required in the extended cabinet for any unit with hot water or final filter option.

## ELECTRICAL DATA

### Electrical Service Sizing

In order to use the electrical service required for the cooling only YPAL rooftop, use the appropriate calculations listed below from U.L. 1995. Based on the configuration of the rooftop, the calculations will yield different MCA (minimum circuit ampacity), and MOP (maximum overcurrent protection).

Using the following load definitions and calculations, determine the correct electrical sizing for your unit. All concurrent load conditions must be considered in the calculations, and you must use the highest value for any combination of loads.

### Load Definitions

- **LOAD1** is the current of the largest motor – compressor or fan motor.
- **LOAD2** is the sum of the remaining motor currents that may run concurrently with LOAD
- **LOAD3** is the current of the electric heaters – zero for cooling only units.
- **LOAD4** is the sum of any remaining currents greater than or equal to 1.0 amp.

Use the following calculations to determine MCA and MOP for units supplied with a single-point power connection:

$$\text{MCA} = (1.25 \times \text{LOAD1}) + \text{LOAD2} + \text{LOAD3} + \text{LOAD4}$$

$$\text{MOP} = (2.25 \times \text{LOAD1}) + \text{LOAD2} + \text{LOAD3} + \text{LOAD4}$$

If the MOP does not equal a standard current rating of an overcurrent protective device, then the marked maximum rating is to be the next lower standard rating. However, if the device selected for MOP is less than the MCA, then select the lowest standard maximum fuse size greater than or equal to the MCA.

**TABLE 3 - ELECTRICAL DATA**

**SUPPLY, EXHAUST, RETURN FAN MOTOR DATA**

**2**

OPEN MOTOR HIGH EFFICIENCY				
MOTOR HP	208/3/60 FLA	230/3/60 FLA	460/3/60 FLA	575/3/60 FLA
5	16.1	13.2	6.6	5.3
7.5	25.0	21.6	10.8	8.2
10	33.0	28.0	14.0	11.0
15	44.8	40.6	20.3	16.2
20	61.0	50.0	25.0	20.0
25	74.0	62.0	31.0	23.8
30	87.0	72.0	36.0	28.0
40	113.0	98.0	49.0	38.8
50	144.0	124.0	62.0	49.2
60	167.0	144.0	72.0	57.4

OPEN MOTOR PREMIUM EFFICIENCY				
MOTOR HP	208/3/60 FLA	230/3/60 FLA	460/3/60 FLA	575/3/60 FLA
5	14.9	12.8	6.4	5.2
7.5	21.3	20.0	10.0	7.4
10	29.0	25.8	12.9	10.3
15	40.7	35.4	17.7	14.1
20	54.3	47.0	23.5	18.9
25	69.5	60.0	30.0	24.2
30	81.0	70.0	35.0	28.0
40	111.0	92.0	46.0	37.4
50	137.0	114.0	57.0	46.0
60	160.0	136.0	68.0	56.0

TOTALLY ENCLOSED HIGH EFFICIENCY				
MOTOR HP	208/3/60 FLA	230/3/60 FLA	460/3/60 FLA	575/3/60 FLA
5	15.2	13.4	6.7	5.4
7.5	24.8	20.4	10.2	8.2
10	29.5	28.4	14.2	11.4
15	43.7	38.8	19.4	15.5
20	60.0	48.0	24.0	19.1
25	73.0	60.0	30.0	24.2
30	87.0	74.0	37.0	29.6
40	113.0	94.0	47.0	38.0
50	140.0	118.0	59.0	47.4
60	161.0	140.0	70.0	56.0

TOTALLY ENCLOSED PREMIUM EFFICIENCY				
MOTOR HP	208/3/60 FLA	230/3/60 FLA	460/3/60 FLA	575/3/60 FLA
5	14.6	13.0	6.5	5.2
7.5	22.0	20.0	10.0	8.0
10	28.5	25.0	12.5	10.0
15	42.4	37.0	18.5	14.8
20	56.0	48.0	24.0	19.0
25	68.4	60.0	30.0	23.9
30	83.0	72.0	36.0	29.0
40	107.0	94.0	47.0	37.0
50	131.0	118.0	59.0	46.0
60	159.0	138.0	69.0	55.0

CONDENSER FAN MOTORS / TOTAL				
NOMINAL TONS	208/3/60 FLA	230/3/60 FLA	460/3/60 FLA	575/3/60 FLA
70	43.8	37.2	18.6	15
75	43.8	37.2	18.6	15
80	43.8	37.2	18.6	15
85	43.8	37.2	18.6	15
90	43.8	37.2	18.6	15
95	43.8	37.2	18.6	15
105	43.8	37.2	18.6	15

CONTROL TRANSFORMER				
DESCRIPTION	NOMINAL VOLTAGE			
	208/3/60 AMPS	230/3/60 AMPS	460/3/60 AMPS	575/3/60 AMPS
YPAL070-105	4.8	4.3	2.2	1.7

**TABLE 3 – ELECTRICAL DATA (CONT'D)**

COMPRESSOR DATA R-410A								
MODEL	COMPRESSOR	MODEL	NOMINAL VOLTAGE					
			208-230/360		460-3-60		575/3/60	
			RLA	LRA	RLA	LRA	RLA	LRA
070	1 A & B	ZP120	33.3	239	17.9	125	12.8	80
	2 A & B	ZP120	33.3	239	17.9	125	12.8	80
	3 A & B	ZP137	48.0	245	18.6	125	14.7	100
075	1 A & B	ZP137	48.0	245	18.6	125	14.7	100
	2 A & B	ZP137	48.0	245	18.6	125	14.7	100
	3 A & B	ZP154	51.3	300	22.4	150	19.8	109
080	1 A & B	ZP137	48.0	245	18.6	125	14.7	100
	2 A & B	ZP154	51.3	300	22.4	150	19.8	109
	3 A & B	ZP154	51.3	300	22.4	150	19.8	109
090	1 A & B	ZP154	51.3	300	22.4	150	19.8	109
	2 A & B	ZP182	55.7	340	26.9	172	23.7	132
	3 A & B	ZP182	55.7	340	26.9	172	23.7	132
105	1 A & B	ZP235	73.9	505	30.4	225	24.6	180
	2 A & B	ZP182	55.7	340	26.9	172	23.7	132
	3 A & B	ZP235	73.9	505	30.4	225	24.6	180

All data given applies to individual compressors

ELECTRIC HEAT				
KW	NOMINAL VOLTAGE			
	208/3/60	230/3/60	460/3/60	575/3/60
	AMPS	AMPS	AMPS	AMPS
40	96	96	48	40
80	193	193	96	80
108	260	260	130	109
150	—	—	181	151
200	—	—	241	201
250	—	—	301	251

**TABLE 4 - AIRFLOW AND ENTERING AIR/AMBIENT LIMITATIONS**

Limitations	Model Size								
	50	55	60	65	70	75	80	90	105
Minimum Airflow at Standard Design Conditions. CFM* (min to max)	10000 - 22500	12000 - 24000	14000 - 27000	14000 - 27000	14000 - 32000	14000 - 32000	14000 - 32000	18000 - 36000	20000 - 36000
Entering Wet Bulb Temp (°F) (min/max)	57/75	57/75	57/75	57/75	57/75	57/75	57/75	57/75	57/75
Entering Dry Bulb Temp (°F) (min/max)	68/90	68/90	68/90	68/90	68/90	68/90	68/90	68/90	68/90
Ambient Temp (°F) without Low Amb option	50/120	50/120	50/120	50/120	50/120	50/120	50/120	50/120	50/120
Ambient Temp (°F) with Low Amb option	0/120	0/120	0/120	0/120	0/120	0/120	0/120	0/120	0/120

\* Cooling Only Units

## FILTERS

Two-inch “throwaway” filters are standard and factory installed in a filter rack located prior to the evaporator coil. Any optional pre-filters ordered with the unit will be shipped inside the unit, but must be filed installed. The unit can also be ordered with an extended cabinet and 95% efficient post-filters. These post-filters are installed at the factory.

Pre-filters must always be installed ahead of the evaporator coil. Post and pre-filters must be kept clean and replaced with the same size and type as shipped with the unit. Dirty filters will reduce the capacity of the unit and may result in frosted coils and safety shutdowns. Required filter sizes and qualities are shown in *Table 2 on page 20*. The unit should never be operated for any length of time without the proper filters installed in the unit.

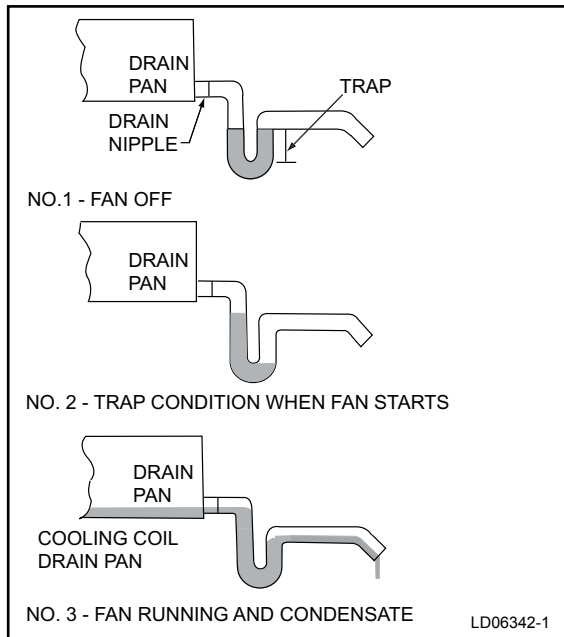
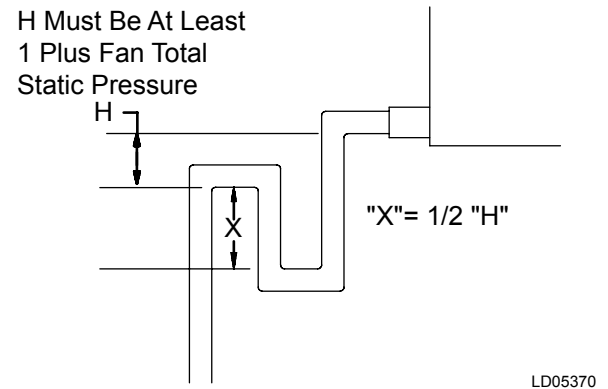

**FIGURE 5 - DRAIN TRAP SHOWING WATER LOCATION DURING DRAW THROUGH OPERATION STAGES**

## CONDENSATE DRAIN

### Condensate Drain Piping

The YPAL 2 cooling coils are located in the units so that the supply air is drawn through them. This results in the condensate being subjected to negative (-) static pressure. Unless some means of pressure equalization is provided in the condensate drain, the air rushing back through the drainpipe will cause the condensate to build up in the drain pan. As the unit continues to operate, the accumulated water will be carried with the air stream, overflowing the drain pan causing possible water leaks into the supply duct and/or causing water damage in the building. A trap must be installed to prevent this condensate water build-up (*see Figure 5 on page 29 and Figure 6 on page 29*).

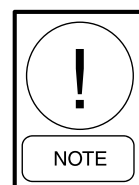

**FIGURE 6 - TRAP DETAIL FOR DRAW THROUGH APPLICATION**

### Condensate Drain Trap

For “Draw-through” applications install a trapped condensate drain line at unit drain connection (*see Figure 6 on page 29*) according to all governing codes. “H” dimension must be at least 1 inch greater than design Total Static Pressure (TSP) of fan.

The trap and drain lines should be protected from freezing. Plumbing must conform to local codes. Use a sealing compound on male pipe threads. Install condensate drain lines from the 1-1/4 inch NPT female connections on the unit to an open drain.



***The unit must be properly trapped and charged with water before the units are started.***

## AIR HOODS FOR ECONOMIZER

There are three economizer outside air intake hoods provided with the unit. The hood on the end of the unit is factory mounted. The two front and rear hoods are made operational per the following instructions:

1. Remove the screws holding the economizer hood shipping covers in place. Discard covers.
2. Apply a bead of RTV sealer along the edge of both hoods and each pivot joint to prevent water leakage.
3. Rotate the hoods out (each hood is hinged). Secure the hoods with screws along the top and sides.
4. Seal any unused screw holes with RTV or by replacing the screw.

## AIR HOODS FOR FIXED OUTSIDE AIR (UNITS WITHOUT ECONOMIZER)

These hoods are factory installed. The dampers may be adjusted by loosening the thumb screw, turning the lever to the desired position, and retightening the thumb screw.

## AIR HOODS FOR EXHAUST AIR

When furnished, these hoods and dampers are factory installed.

## FIELD WIRING

*Figure 7 on page 33 and Figure 8 on page 34* show the field control wiring to CTB1. All field control wiring is field supplied and installed.

### Thermostat

A thermostat (2 stage cool or 2 stage heat) can be used on CV units. On CV units the thermostat is the primary means of control for the unit. The thermostat should be mounted on an inside wall approximately 56" above the floor where it will not be subject to drafts, sun exposure or heat from electrical fixtures or appliances.

### Space Sensor

The space sensor (if used) can be used on either CV or VAV units. The space saver sensor can be used for unit control in lieu of a thermostat on CV units. For SZVAV units, only a space sensor can be used. This can be hardwired or a communicated signal. Even if a thermostat is wired to the rooftop unit, the space sensor will supply space air temperature values if connected. When mounting a space sensor, it should be located on an inside wall approximately 56 inches above the floor where it will not be subject to drafts, sun exposure or heat from electrical fixtures or appliances. **Shielded Wire must be used that is grounded at control panel only.**

### CO<sub>2</sub> Sensor

The optional CO<sub>2</sub> sensor is used for demand ventilation. When ordered a CO<sub>2</sub> sensor is installed in the outdoor and return air stream.

### Occupied/Unoccupied Input

A contact-closure input is provided for hard-wiring an external device such as a central time clock, a thermostat with scheduling or BAS system, or a manual switch.

Contact Closure = Occupied

Contacts Open = Unoccupied

Note that 24 volts (24VAC), terminal 1 of the terminal block CTB1, must be used as the 24VAC source for switching the contact to the Unit Controller Occupied/Unoccupied input. Use of any power source external to the controller will result in damage to the Unit Controller.

### Shutdown Input

A contact-closure input is provided for emergency shutdown of the unit. When this circuit is open, the unit shuts down with supply fan, exhaust fan turned OFF, and outside air dampers are closed. This state is maintained until the input is activated (contacts closed).

- Contact Closed = Normal Operation
- Contacts Open = Shutdown

Note that a jumper is installed at the factory between terminals 3 (24VAC) and terminal 4 (SD) of the low voltage terminal block CTB1. When a field shutdown input is used, the jumper must be removed and the external dry contact connected between terminal 3 and 4. The connection of an external power supply to these terminals will result in damage to the Unit Controller.

### Smoke Purge Input

There are three field connection points for Smoke Purge operation, “Smoke Purge 1”, “Smoke Purge 2” and “Smoke Purge 3”. When a field supplied dry contact is closed between terminal 3 (24VAC) and terminal 6 (SMK1) the unit will initiate whatever smoke purge sequence has been programmed into the Unit Controller for Smoke Purge Sequence 1. When a field supplied dry contact is closed between terminal 3 (24VAC) and terminal 7 (SMK2) the unit will initiate whatever smoke purge sequence has been programmed into the Unit Controller for Smoke Purge Sequence 2. When a field supplied dry contact is closed between terminal 3 (24VAC) and terminal 8 (SMK3) the unit will initiate whatever smoke purge sequence has been programmed into the Unit Controller for Smoke Purge Sequence 3. Refer to “Smoke Purge” on page 100 for additional programming information. The Smoke Purge operating state will be maintained until the contact is opened.

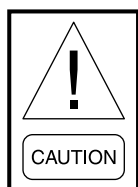

***No external power source may be used when field wiring any of the above inputs. The 24VAC source on terminal 3 of the terminal block CTB1 must be used as the power source when field wiring these inputs, as shown in Figure 7 and 8. Failure to do so will result in improper unit operation and damage to the Unit Controller.***

### VAV Heat Relay Output

This is a field wired *OUTPUT* that is used to command the VAV boxes to full open during morning warm up operation. This 24VAC signal should have a maximum current draw not to exceed 20VA. If the VA requirement of the VAV boxes approaches 20VA, isolation relays should be field supplied and installed to avoid overloading the unit power supply.

Note that this signal is used to drive the VAV boxes open in morning warm up operations. Failure to drive the VAV boxes open during this mode of operation can cause unit shutdown and/or damage to the ductwork due to over pressurization.

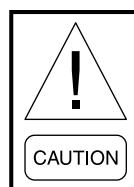

***The VAV Heat Relay Output cannot exceed a current draw of 20VA. If the power requirements of the VAV boxes exceed this amount, isolation relays must be field supplied and installed to prevent overloading the Unit Controller power supply.***

### RETURN AIR BYPASS DAMPER

Units built with the FlexSys option will have an opening in the base of the unit between the evaporator coil and the supply air blower. A FlexSys unit requires a means to bypass return air and mix it with the air off the evaporator coil. YORK does have a special curb with the return duct bypass built into the curb. The purpose of the damper is to temper the supply air to the under floor system by mixing return air with the air off the evaporator coil. After the system is initialized, the mixed air damper modulates based on the ratio of the difference between the mixed air temperature minus the supply air temperature compared to the return air temperature minus the supply air temperature. As the mixed air temperature decreases, the damper opens allowing more air to bypass the evaporator coil resulting in a higher mixed air temperature supply to the under floor system.

The mixed air damper must be wired and installed into the system in the field. The wires to connect the actuator are located in the supply fan section, in the proximity of the actuator in the supply fan section floor, opposite the supply fan motor side. The plug assembly/wires are attached with an elastic band and must be wired to the actuator, and the “plugs” mated together. Connect the wires to the motor as follows:

- Wire labeled “412” to terminal 1 in the actuator
- Wire labeled “303” to terminal 2 in the actuator
- Wire labeled “411” to terminal 5 in the actuator

## **BACNET COMMUNICATION**

The YPAL rooftop unit can communicate to any building automation system using BACnet MSTP communication protocol.

The field connections are made by connecting shielded two-wire cable to Port 1 on the IPU control board.

*Refer to Communication on page 131 for additional information.*

## **DIRTY FILTER SWITCH**

On units with a dirty filter switch option, an adjustable differential pressure switch is installed to monitor the pressure drop across the filters. When the pressure drop across the filters exceeds the setting of the switch the switch closes sending a 24-volt signal to the Unit Controller. The Unit Controller posts a trouble fault in the service memory buffer; but will not shut down the unit.

## **ALARM CONTACTS**

The Unit Controller has three sets dry Alarm Contacts that are closed during a fault. If the unit experiences a Supply Fan Fault, the Unit Controller will close a set of dry contacts between terminals 28 and 29 of the low voltage terminal block (CTB1). If the unit experiences a Cooling/Heating Fault, the Unit Controller will close a set of dry contacts between terminals 30 and 31 of the low voltage terminal block (CTB1). If the unit experiences a Sensor/Misc. Fault, the Unit Controller will close a set of dry contacts between terminals 32 and 33 of the low voltage terminal block (CTB1).



## CTB1 FIELD CONTROL WIRING (INPUTS)

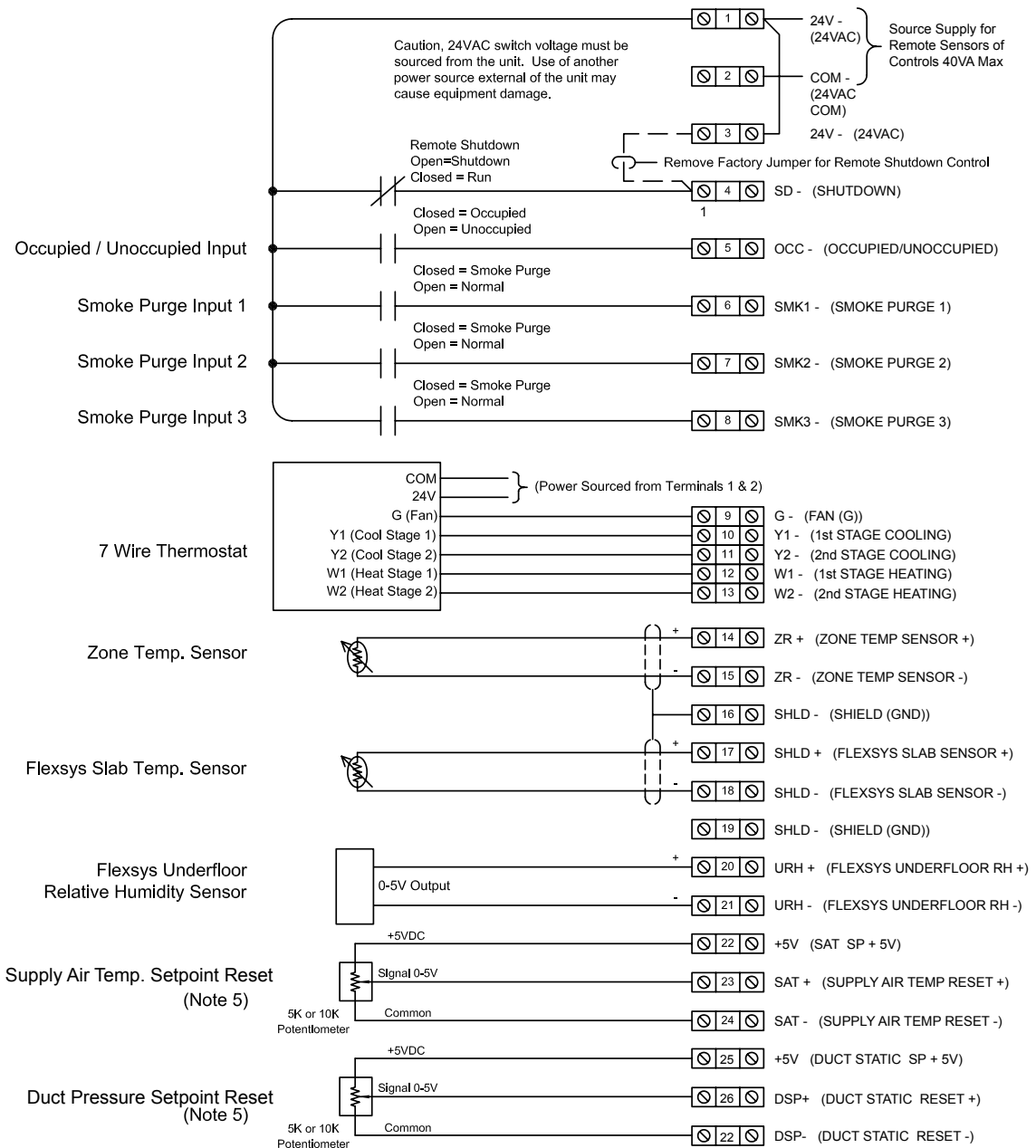

LD08184D

### WIRING NOTES

1. Wiring shown indicates typical wiring. Refer to IOM for more detailed wiring methods and options.
2. All wiring is Class 2, low voltage.
3. Maximum power available from the 24VAC terminal is 40VA.
4. Use shielded wire where shown.
5. Potentiometer application shown. As an alternative, signal inputs can be driven from an analog output of a third party controller. Note: Input resistance is 15 K ohms.
6. The FlexSys Underfloor Relative Humidity Sensor is field supplied. In addition to two wires which transmit the 0 to 5VDC signal from the sensor to the Unit Controller, the Underfloor Relative Humidity Sensor will also need to be powered. The type of voltage required to power the sensor will depend on the sensor selected. If the sensor uses 24VAC additional wires will need to be run to terminal 1 (24VAC) and terminal 2 (24VAC COM) of the CTB1 terminal block. If the sensor required a different power source than 24VAC it will need to be field supplied.

FIGURE 7 - FIELD CONTROL WIRING - INPUTS

### CTB1 FIELD CONTROL WIRNG (OUTPUTS)

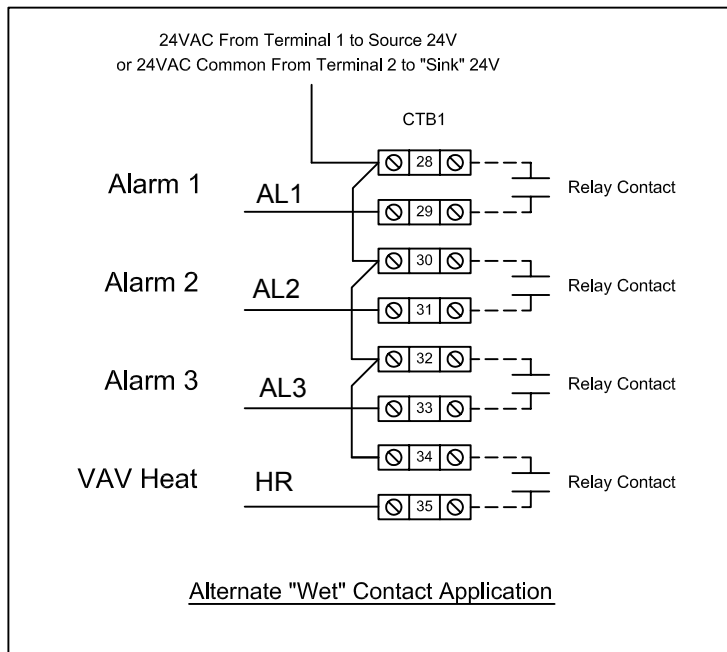
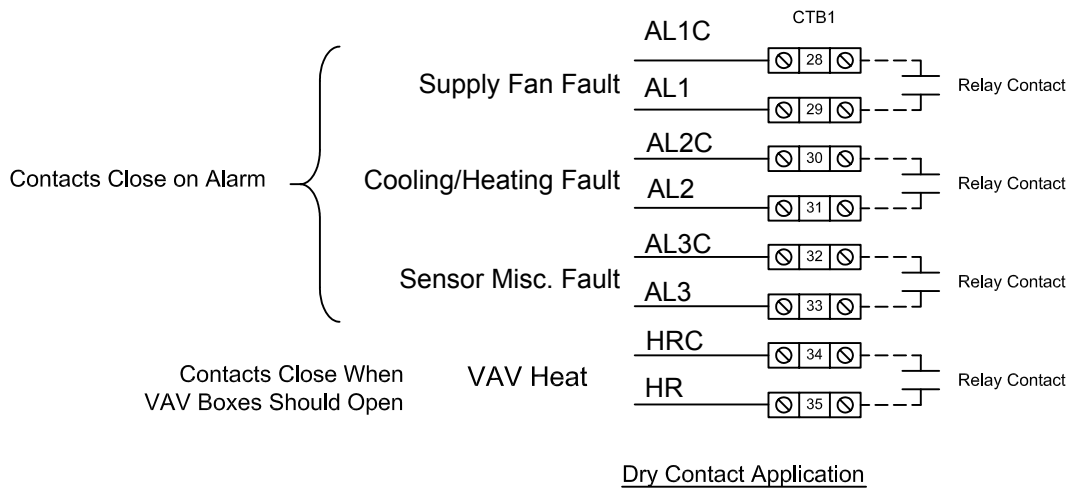

Id08186C

**WIRING NOTES:**

1. Wiring shown indicates typical wiring. Refer to the IOM for more detailed wiring methods and options.
2. All wiring is Class 2, low voltage.
3. Maximum power available from the 24VAC terminal is 40VA.
4. Use shielded wire where shown.
5. Relay contacts suitable for pilot duty to 1A from 24VAC to 120VAC.

**FIGURE 8 - FIELD CONTROL WIRING - OUTPUTS**

## POWER WIRING

Field wiring to the unit must conform to provisions of National Electrical Code (NEC) ANSI / NFPA 70 latest edition and / or local ordinances. The unit must be electrically grounded in accordance with the NEC and / or local codes. Voltage tolerances, which must be maintained during starting and running conditions, are indicated on the unit data plate.

The internal wiring harnesses furnished with this unit are an integral part of the design certified unit. Field alteration to comply with electrical codes should not be required. If any of the wire supplied with the unit must be replaced, replacement wire must be of the type shown on the wiring diagram and the same minimum gauge as the replaced wire.

Power supply to the unit must be NEC Class 1 and must comply with all applicable codes. A disconnect switch must be provided (factory option available). The switch must be separate from all other circuits. Wire entry at knockout openings requires conduit fittings to comply with NEC and/or Local Codes.

Refer to *Figure 9 on page 36*, *Figure 10 on page 37*, and *Figure 11 on page 38* for typical field wiring and to the appropriate unit wiring diagram mounted inside control doors for control circuit and power wiring information.

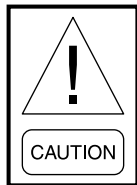

***Field power wiring connected to the incoming power termination point must be copper conductor only. Aluminum wire cannot be connected to the incoming power termination point.***

## ELECTRICAL SERVICE SIZING

Electrical service required for the cooling only YPAL rooftop, use the appropriate calculations listed below from U.L. 1995. Based on the operating mode and configuration of the rooftop, the calculations will yield different MCA (minimum circuit ampacity), and MOP (maximum overcurrent protection). **MCA and Overcurrent Protection Device Data is supplied on the unit data plate.**

The following calculations apply to electrical data for the rooftop unit. All concurrent load conditions must be considered in the calculations, and you must use the highest value for any combination of loads.

**Minimum Circuit Ampacity (MCA)** is based on 125% of the rated load amps for the largest motor plus 100% of the rated load amps for all other loads included in the circuit, per N.E.C. Article 440-34.

The minimum recommended disconnect switch is based on 115% of the rated load amps for all loads included in the circuit, per N.E.C.

**Maximum overcurrent protection** is based upon 225% of the rated load amps for the largest motor plus 100% of the rated load amps for all other loads included in the circuit, per N.E.C. Article 440-22. If the maximum overcurrent protection does not equal a standard current rating of an overcurrent protective device, then the marked maximum rating is to be the next lower standard rating. However, if the device selected for maximum overcurrent protection is less than the MCA, then select the lowest standard maximum fuse size greater than or equal to the MCA.

*Figure 9 on page 36*, *Figure 10 on page 37*, and *Figure 11 on page 38* show the power wiring that must be field supplied and installed.

For dual point power connections, TB1 in the power panel supplies the all unit compressors and condenser fans. TB2 in the power panel supplies power to the unit supply, return and exhaust fans, and control circuitry.

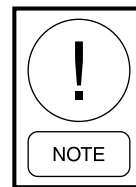

***All wiring must conform to the National Electrical Code (NEC) and local codes that may be in addition to NEC.***

## SINGLE-POINT POWER SUPPLY WIRING

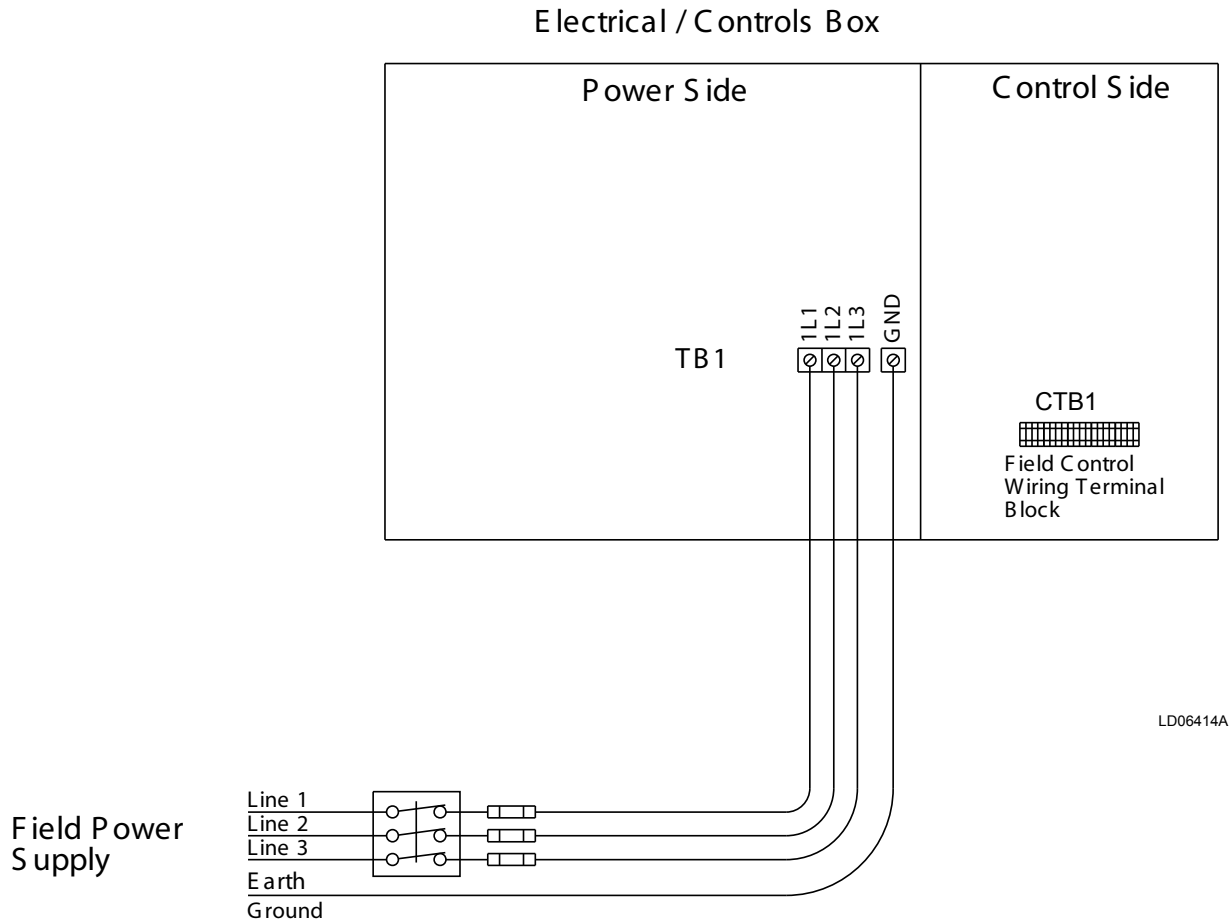

### NOTES:

1. All field wiring must be provided through a field-supplied fused disconnect switch to the unit terminals (or optional molded disconnect switch).
2. All electrical wiring must be made in accordance with all N.E.C. and/or local code requirements.
3. Minimum Circuit Ampacity (MCA) is based on U.L. Standard 1995, Section 36.14 (N.E.C. Section 440-34).
4. Maximum Dual Element Fuse size is based on U.L. Standard 1995, Section 36.15 (N.E.C. Section 440-22).
5. Use copper conductors only.
6. On units with an optional disconnect switch, the supplied disconnect switch is a "Disconnecting Means" as defined in the N.E.C. Section 100, and is intended for isolating the unit from the available power supply to perform maintenance and troubleshooting. This disconnect switch is not intended to be a Load Break Device.

**FIGURE 9 - SINGLE-POINT POWER SUPPLY WIRING**

# SINGLE-POINT POWER SUPPLY WIRING WITH NON-FUSED DISCONNECT SWITCH

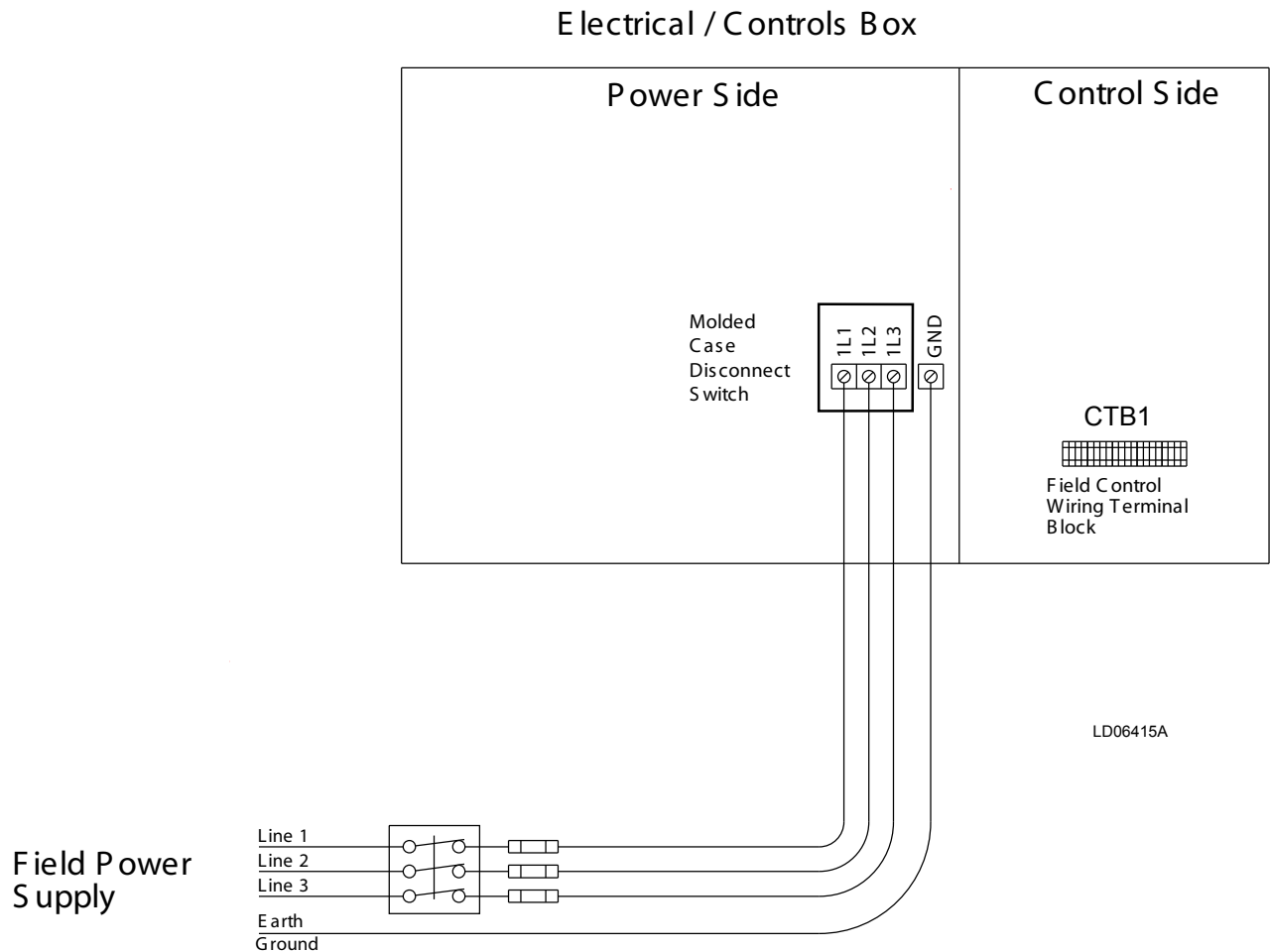

**NOTES:**

1. All field wiring must be provided through a field-supplied fused disconnect switch to the unit terminals (or optional molded disconnect switch).
2. All electrical wiring must be made in accordance with all N.E.C. and/or local code requirements.
3. Minimum Circuit Ampacity (MCA) is based on U.L. Standard 1995, Section 36.14 (N.E.C. Section 440-34).
4. Maximum Dual Element Fuse size is based on U.L. Standard 1995, Section 36.15 (N.E.C. Section 440-22).
5. Use copper conductors only.
6. On units with an optional disconnect switch, the supplied disconnect switch is a "Disconnecting Means" as defined in the N.E.C. Section 100, and is intended for isolating the unit from the available power supply to perform maintenance and troubleshooting. This disconnect switch is not intended to be a Load Break Device.

**FIGURE 10 - SINGLE-POINT POWER SUPPLY WIRING WITH NON-FUSED DISCONNECT**



## TRANSDUCER PNEUMATIC TUBING

### Static Pressure Control Plastic Tubing (Pneumatic Tubing)

Duct static transducers (all VAV units) and any unit with an optional building pressure control transducer, require pneumatic tubing to be field supplied and installed. The “High” side of the respective transducer must be routed to the location in the building or ductwork where a constant pressure is desired. Both the duct static transducer (VAV only) and optional building pressure transducer are mounted behind the left hand damper door. All wiring from the transducers is factory installed.

#### Duct Static Transducer

Plastic tubing (3/16" ID) must be run from the high pressure tap of the transducer to a static pressure tap (field supplied) in the supply duct, located at a point where constant pressure is desired. This is normally 2/3rds of the way down the duct, before the first take off.

#### Building Pressure Transducer

Plastic tubing (3/16" ID) must be run from the high pressure tap of the building static pressure transducer to a static pressure tap (field supplied) located in the conditioned space. The tap should be placed in a location where over pressurization will cause a problem (e.g., in the lobby area where excessive pressure will cause the doors to remain open). The tap should never be placed above the ceiling.

This will allow for standard building pressure control through the unit controller. There is an option to control the VFD Driven Exhaust Fan speed through the BAS, if desired. If the unit has a return fan, the same point can be used to control the Modulating Exhaust Damper. The point for BAS control can be enabled in the Service key.

#### Static Pressure Probe Installation

On units with duct static transducers (VAV units) and any unit with an optional building pressure, a factory supplied Static Pressure Probe must be field installed at the top of the rear corner post on the unit (see *Figure 12 on page 40*).

The factory supplied atmospheric pressure probe and associated mounting hardware are shipped inside the unit controller panel. The hardware consists of a mounting bracket and a short section of pneumatic tub-

ing. **The pneumatic tubing must be field installed from a factory pressure tap (next to the mounting location for the static pressure probe) to the atmospheric pressure probe (see *Installation Instructions (Form 100.50-N1)*).**

If the unit is equipped with both a building pressure transducer and a duct static transducer, a “tee” will be factory installed, and both the duct static pressure transducer and building pressure will be connected to the “tee” - both building static pressure transducer and duct static transducer will use the same factory supplied atmospheric pressure probe.

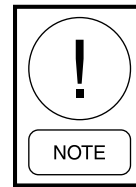

***The “Low” side connection of the duct static or building pressure transducers are shipped with the pneumatic tubing factory installed and routed, to the external factory pressure tap.***

## ROOF CURB INSTALLATION

### General Information

When ordered, the roof curb is shipped knocked-down in a separate container and needs to be field assembled and installed. *Refer to Installation Manual that is shipped with the roof curb for specific instructions.*

On full perimeter roof curb the opening in the roof should not extend under the condenser section of the curb. The condenser section of the roof curb is not insulated and could result in condensation build up under the condenser section as well as higher than normal sound levels in the conditioned space.

The roof curb drawings contained in the Johnson Controls literature are not intended as construction documents for the field fabrication of a roof curb. Johnson Controls will not be responsible for the unit fit up, leak integrity, or sound level with field fabricated roof curbs. Construction documents for field fabricated roof curbs are available upon request.

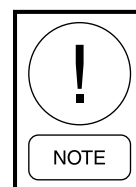

***Wood or Fiber Cant Strips, Roofing Felts, Roofing Material, Caulking and Curb-To-Roof Fasteners are to be field supplied.***

## DUCT SYSTEM

### Duct Connection Guidelines

All intake and discharge air duct connection to the unit may be made directly to the unit. These air duct connections should be on flexible material and should be installed so they are sufficiently loose. Duct runs and transitions must be made carefully to hold friction loss to a minimum. Avoid short turns, and duct elbows should contain splitters or turning vanes.

Duct work connected to the fan discharge should run in a straight line for at least **two** equivalent outlet diameters. Never deadhead the discharge into the flat surface of a plenum.



*Installation of elbows, discharge damper and other abrupt flow area changes installed directly at the fan outlet will cause system losses. These losses must be taken into account during the design phase and must be added to any field measurements.*

## SOUND AND VIBRATION TRANSMISSION

All roof mounted air handling units generate some sound and vibration, which may or may not require some special treatment of the air conditioned space. The noise generated by the air handling unit is dependent on the speed of the fan, the amount of air the fan is moving, the fan type and the static efficiency of the fan. In applications where sound and vibration transmissions may be objectionable, good acoustical engineering practices must be incorporated in the system design.

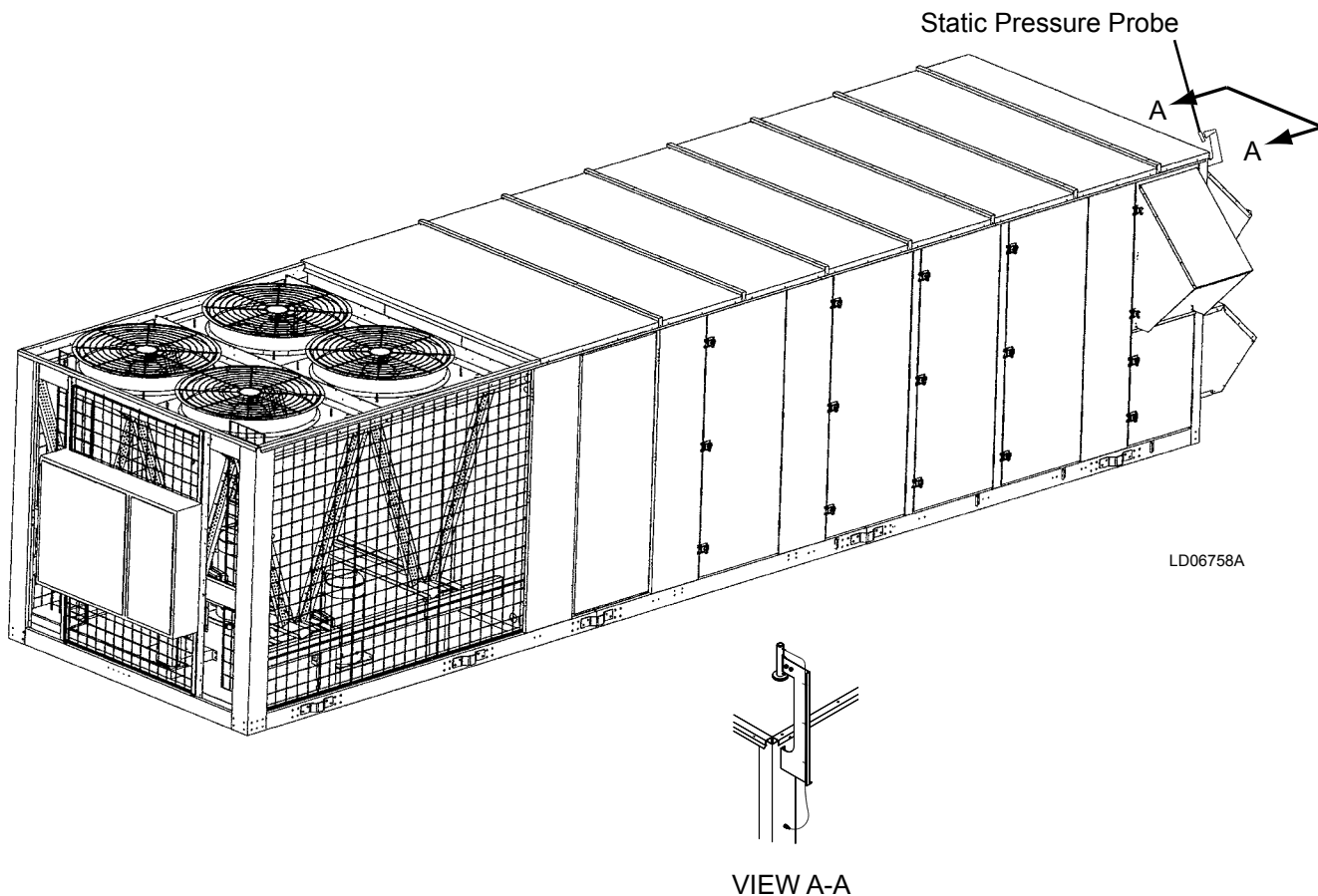

**FIGURE 12 - STATIC PRESSURE PROBE LOCATION**



## GAS HEATING

### Gas Piping

Proper sizing of the gas piping depends on the cubic feet per hour of gas flow required, specific gravity of the gas and the length of run. The latest edition of the National Fuel Gas Code Z223.1 should be followed in all cases unless superseded by local codes or gas company requirements. Refer to *Table 5 on page 41*.

**TABLE 5 - PIPE SIZES**

LENGTH IN FEET	NOMINAL IRON PIPE SIZE	
	1-1/2 IN. <sup>1</sup>	2 IN. <sup>1</sup>
10	1,600	3,050
20	1,100	2,100
30	890	1,650
40	760	1,450
50		1,270
60		1,150
70		1,050
80		990

<sup>1</sup> Maximum capacity of pipe in cubic feet of gas per hour (based upon a pressure drop of 0.3 inch water column and 0.6 specific gravity gas).

The heating value of the gas may differ with locality. The value should be checked with the local gas utility.

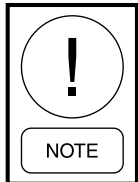

***There may be a local gas utility requirement specifying a minimum diameter for gas piping. All units require a 1 1/2-inch pipe connection at the entrance fitting. Line size should not be sized smaller than the entrance fitting size.***

### Gas Connection

The gas supply line should be routed within the space and penetrate the roof at the gas inlet connection of the unit. Many local codes require that a shut off valve be located external to the unit. In these cases it is easier to run the gas piping on the roof and enter the unit through the side of the base rail. Typical supply piping arrangements are shown in *Figure 13 on page 41*.

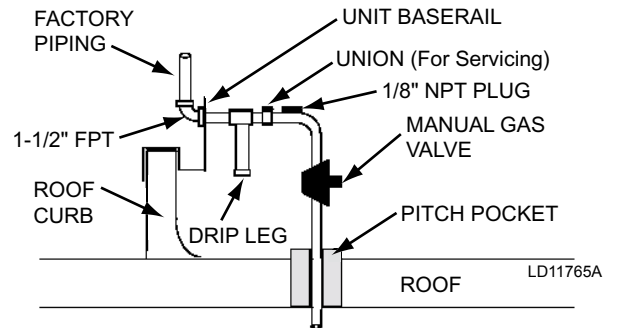

**FIGURE 13 - TYPICAL GAS PIPING CONNECTION**

### Gas Piping Recommendations

1. A drip leg and a ground joint union must be installed in the gas piping.
2. When required by local codes, a manual shut-off valve will have to be installed outside of the unit.
3. Use wrought iron or steel pipe for all gas lines. Pipe dope should be applied sparingly to male threads only.



***Natural gas may contain some propane. Propane being an excellent solvent will quickly dissolve white lead or most standard commercial compounds. Therefore, a special pipe dope must be applied when wrought iron or steel pipe is used. Shellac base components such as Gaskolac or Stalastic, and compounds such as Rectorseal #5, Clyde's or John Crane may be used.***

4. All piping should be cleaned of dirt and scale by hammering on the outside of the pipe and blowing out the loose particles. Before initial start-up, be sure that all of the gas lines external to the unit have been purged of air.
5. The gas supply should be a separate line and installed in accordance with all safety codes as prescribed under "Limitations" listed in the beginning of *SECTION 2 – INSTALLATION* of this manual. After the gas connections have been completed, open the main shutoff valve admitting gas pressure to the mains. Check all joints for leaks with soap solution or other material suitable for the purpose. **NEVER USE A FLAME!**
6. The furnace and its individual manual shut-off valve must be disconnected from the gas supply piping system during any pressure testing of that system at test pressures in excess of 0.5 PSIG.



***Disconnect gas piping from unit when leak testing at pressures greater than 0.5 PSIG. Pressures greater than 0.5 PSIG will cause gas valve damage resulting in a hazardous condition. If gas valve is subjected to pressure greater than 0.5 PSIG, it must be replaced.***

7. A 1/8 inch N.P.T plugged tapping, accessible for test gage connection, must be installed immediately upstream of the gas supply connection to the furnace.

### Combustion Vent

The combustion vent assembly is shipped in the return air section of the unit. The combustion vent assembly must be mounted over the flue gas outlet fixed panel located to the right of the gas heat access door. Install as follows:

1. Remove the combustion vent assembly from the return compartment.
2. Remove the vertical row of six screws on either side of the flue gas outlet fixed panel.
3. Mount the combustion vent assembly over the flue gas outlets and attach to the gas outlet fixed panel using the screws removed in step 2.
4. See *Figure 14 on page 42* for the proper orientation of the combustion vent. The internal baffle(s) must direct the flue gases upward.

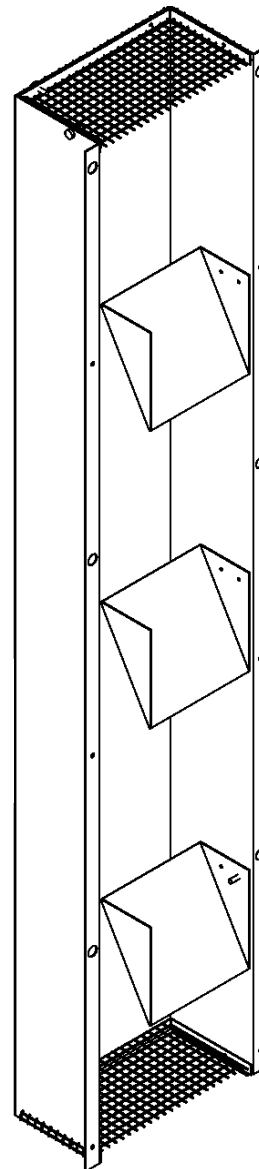

**FIGURE 14 - COMBUSTION VENT**

## SECTION 3 – START-UP

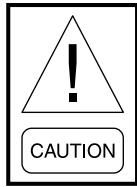

*To protect warranty, this equipment must be installed and serviced by an authorized Johnson Controls service mechanic or a qualified service person experienced in air handling and condenser unit installation. Installation must comply with all applicable codes, particularly in regard to electrical wiring and other safety elements such as relief valves, HP cut-out settings, design working pressures and ventilation requirements consistent with the amount and type of refrigerant charge.*

*Lethal voltages exist within the Control Panel. Before servicing, open and tag all disconnect switches.*

*Reference Quick Startup Guide (Form 100.50-SU1) for additional information.*

### CRANKCASE HEATERS

With power applied to the rooftop unit, the crankcase heater for each compressor will be ON whenever the compressor is not running. The heater is interlocked into the compressor motor contactor and is not controlled by the microprocessor.

The purpose of the crankcase heater is to prevent the migration of refrigerant to the crankcase during shutdown, assuring proper lubrication of the compressor on start-up.

Anytime power is removed from the unit for more than an hour, the crankcase heater should be left ON for 24 hours prior to start.

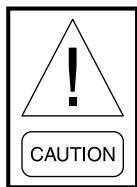

*Power must be applied to the rooftop unit 24 hours prior to starting the unit compressors. Failure to observe this requirement can lead to compressor damage and voiding of the compressor warranty.*

### CHECKING THE SYSTEM PRIOR TO INITIAL START (NO POWER)

#### Unit Checks

1. Inspect the unit for shipping or installation damage.
2. Visually check for refrigerant piping leaks.
3. The compressor oil level should be maintained so that an oil level is visible in the sight glass. The oil level can only be tested when the compressor is running in stabilized conditions, guaranteeing that there is no liquid refrigerant in the lower shell of the compressor. In this case, the oil must be between 1/4 and 3/4 in the sight glass. At shutdown, the oil level can fall to the bottom limit of the oil sight glass.
4. Check the control panel to assure it is free of foreign material (wires, metal chips, etc.).
5. Visually inspect field wiring (power and control). Wiring MUST meet N.E.C. and local codes.
6. Check tightness of terminal lugs inside the power panel on both sides of the contactors, overloads, fuses, and power connections.
7. Verify fuse sizing in main circuits.
8. Verify field wiring for thermostat (if applicable), optional zone sensor, etc.
9. Verify all applicable pneumatic tubing has been field installed for duct static pressure transducers (VAV units), optional building pressure transducer for power exhaust option, and outdoor static pressure probe.
10. Supply fan isolators spring bolts removed (refer to Figure 15 on page 44).
11. Verify proper bearing and locking collar torque values on supply and exhaust fans (refer to SECTION 4 – MAINTENANCE of this manual).
12. Verify proper drive alignment of supply and exhaust fans (refer to SECTION 4 – MAINTENANCE of this manual).



*The supply, exhaust and return fans have tie down bolts installed at the factory to prevent movement in the fan assemblies during shipment. **THESE HOLD DOWN BOLTS MUST BE REMOVED PRIOR TO OPERATION OF THE ABOVE FANS.** There are eight bolts per assembly two at each corner of the fan skirts, front and rear. The bolt locations are shown in Figure 15. The bolt heads are red in color and a label identifies their location in the unit.*

13. Verify proper belt tension of supply fan, exhaust fan or return fan (refer to *SECTION 4 – MAINTENANCE of this manual*). Belts must be checked after 24 hours of initial operation.
14. Manually rotate condenser fan blades, supply exhaust and return blower wheels and motors, to assure freedom of movement.
15. Verify proper condensate drain trap installation (refer to *Figure 15 on page 44*). Fill traps with water prior to unit start-up.
16. If applicable, verify installation of air filters (refer to *SECTION 2 – INSTALLATION of this manual for size and quantity*).

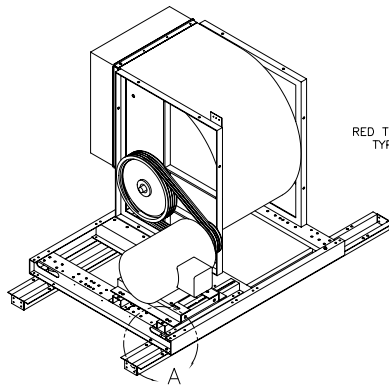

RED TIE DOWN BOLTS  
TYP FOUR PLACES

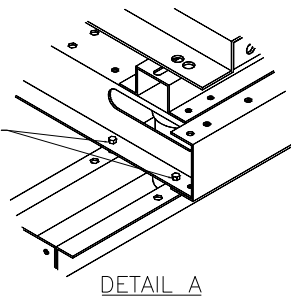

DETAIL A

#### SUPPLY FAN ASSEMBLY

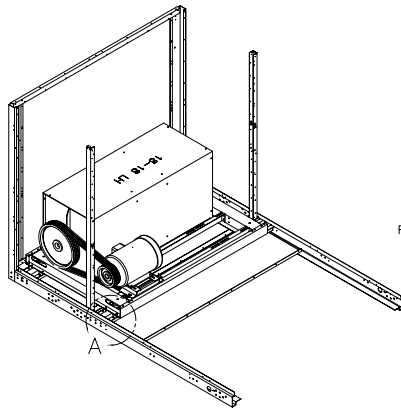

RED TIE DOWN BOLTS  
TYP FOUR PLACES

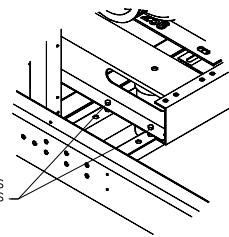

DETAIL A

#### EXHAUST FAN ASSEMBLY

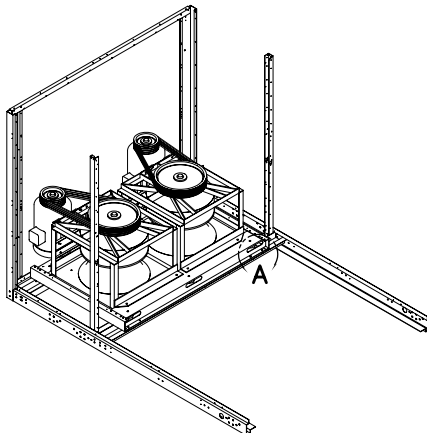

RED TIE DOWN BOLTS  
TYP FOUR PLACES

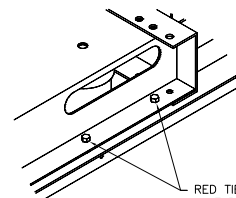

DETAIL A

#### RETURN FAN ASSEMBLY

**FIGURE 15 - FAN ISOLATOR SPRING BOLTS (TOTAL OF 8)**

17. Verify Variable Frequency Drive setpoints for VAV units and optional Variable Frequency Drive Exhaust or Return Fans. Both VFD's are located in the supply blower section of the unit. *Refer to the Installation, Operation & Maintenance Manual (Form 100.40-NO4) and Literature Supplement (Form 100.40-NO4 (LS02) dated 706) supplied with the rooftop unit for VFD operation and programming.*
18. If equipped, open suction line ball valve, discharge line ball valve, and liquid line ball valve for each refrigerant system.

### UNIT CHECKS – POWER APPLIED

1. Apply 3-phase power and verify its value. Voltage imbalance should be no more than 2% of the average voltage.
2. Verify programmed units setpoints (*refer to Quick Start-Up Guide (Form 100.50-SU1)*).
3. Verify correct fan rotation (fan should rotate in direction of arrow on fan housing).
4. Insure proper compressor rotation. *See the following section for instruction on Verifying Compressor Rotation.*

### Verifying Compressor Rotation



***This unit uses scroll compressors, which will only operate in one direction. Failure to observe these steps could lead to compressor failure.***

The YPAL rooftop unit uses hermetic scroll compressors, which only pump in one direction. Therefore, it is necessary to verify proper rotation at unit start-up. Operation of the compressor in the reverse direction will not produce any capacity, and cause the compressor to cycle on internal overload. Operating the compressor in reverse for “extended” periods can result in failure of the compressor.

To verify proper rotation, monitor the suction and discharge pressures of the respective refrigerant circuit while the compressor cycles ON. If the discharge pressure increases and suction pressure decreases as the compressor cycles ON, the compressor is properly phased and operating in the correct rotation.

Suction and discharge pressure may be monitored with the User Interface if the optional suction and discharge pressure transducers are installed (*for menu navigation, refer to User Interface Control Center on page 101*). If the optional transducers are not installed, pressures must be monitored with a manifold gauge connected to the service valves located on the suction and discharge lines.

### Compressor Oil Level Check

The oil level can only be tested when the compressor is running in stabilized conditions, to ensure that there is no liquid refrigerant in the lower shell of the compressor. When the compressor is running in stabilized conditions, the oil level must be between 1/2 and 3/4 in the oil sight glass.

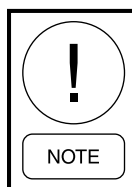

***At shutdown, the oil level can fall to the bottom limit of the oil sight glass.***

**INITIAL START-UP**

After all of the preceding checks have been completed and the control panel has been programmed as required, the unit may be placed into operation by performing the following:

1. Place the Unit Switch in the control panel to the ON position.
2. With a demand, the supply fan will cycle ON, and permit compressor operation if the air proving
3. The first compressor will start. After several minutes of operation, a flow of refrigerant will be noted in the sight glass, the vapor in the sight glass will clear, and there should be a solid column of liquid visible in the sight glass when the TXV stabilizes.
4. Allow the compressor to run a short time, being ready to stop it immediately if any unusual noise or adverse conditions develop.
5. Check the system operating parameters by checking evaporator superheat and condensing subcooling. Connect a gauge manifold set to the Schrader service valve connections on the liquid and common suction line in the condensing section of the unit. After the system is running and the pressures have stabilized, measure the temperature at the liquid and common suction lines near the Schrader service valves. Calculate evaporator superheat and condensing subcooling. Both should be approximately 15 degrees, *Refer to the preceding section Checking Superheat and Subcooling for information on how to calculate evaporator superheat and condenser subcooling.* Repeat the above process for each of the refrigerant systems.
6. With an ammeter, verify that each phase of the condenser fans, compressors, supply fan, and exhaust fan are within the RLA/FLA as listed on the unit data plate.

**Refrigerant Charge**

This rooftop unit comes fully charged from the factory with refrigerant R-410A as standard.

**Checking Superheat and Subcooling**

An R-410A temperature and pressure chart lists the associated *saturation* temperature in one column, with the associated pressure in another column. As a result, only one temperature/pressure column is needed to show the relationship.

**Subcooling (R-410A)**

When the refrigerant charge is correct, there will be no vapor in the liquid sight glass with the system operating under full load conditions.

The subcooling temperature of each system can be calculated by recording the temperature of the liquid line at the outlet of the condenser and subtracting it from the saturation temperature listed in *Table 6 on page 47*, for the corresponding discharge pressure.

*Example:*

On a YPAL 070 the liquid pressure is 375 PSIG and the liquid temperature is 97 °F

Saturation Temperature for 375 PSIG = 112 °F

Minus the liquid line temp = 97 °F

Liquid Line Subcooling of = 15 °F

The subcooling should be 15 °F at design conditions.

**TABLE 6 - R410-A PRESSURE / TEMPERATURE CHART**

PSIG	TEMP °F	PSIG	TEMP °F
0	-60	78	20
2	-58	80	21
4	-54	85	24
6	-50	90	26
8	-46	95	29
10	-42	100	32
12	-39	105	34
14	-36	110	36
16	-33	115	39
18	-30	120	41
20	-28	125	43
22	-26	130	45
24	-24	135	47
26	-20	140	49
28	-18	145	51
30	-16	150	53
32	-14	160	57
34	-12	170	60
36	-10	180	64
38	-8	190	67
40	-6	200	70
42	-4	210	73
44	-3	220	76
46	-2	225	78
48	0	235	80
50	1	245	83
52	3	255	85
54	4	265	88
56	6	275	90
58	7	285	92
60	8	295	95
62	10	305	97
64	11	325	101
66	13	355	108
68	14	375	112
70	15	405	118
72	16	500	134
74	17	600	149
76	19	700	159

**3**

## Superheat (R-410A)

The superheat should be checked only after steady state operation of the unit has been established, the discharge air temperature has been pulled down to within the control range, and the unit is running in a fully loaded condition.

The superheat is calculated as the difference between the actual temperature of the refrigerant gas in the suction line and the temperature corresponding to the Suction Pressure as shown in *Table 6 on page 47*.

*Example:*

The suction pressure is 130 PSIG and the suction line temperature is 57 °F

Suction Line Temperature = 57 °F

Saturation Temperature for 130 PSIG = 45 °F

Evaporator Superheat = 12 °F

When adjusting the expansion valve, the adjusting screw should be turned not more than one turn at a time, allowing sufficient time (approximately 15 minutes) between adjustments for the system and the thermal expansion valve to respond and stabilize.

The superheat setting should be adjusted to 12 °F at design conditions.

## Leak Checking

Leak check compressors, fittings and piping to assure no leaks. Verify the evaporator distributor tubes do not have bare copper touching each other or are against a sheet metal edge. If you are leak checking a unit charged with R-410A make sure the leak test device is capable of sensing refrigerant R-410A.

If the unit is functioning satisfactorily during the initial operating period, no safeties trip and the unit controls are functioning properly, the rooftop unit is ready to be placed into operation.

## Gas Heat Models

### Pre-Start Checks

Startup of gas heat includes verification of incoming gas line pressure and leak checks of the field installed gas lines, these items are the responsibility of the installing contractor; however, they should also be verified prior to unit start-up. Correct values and the proper procedures are described later in this section of the manual.

Verify wiring inside the burner compartment to insure the wiring/terminals are tight and securely connected to the components, such as the ignition control, flame sensor, gas valve, rollout switches and igniter.

The gas heat start up sequence begins with a 30 second prepurge. The next step in the sequence is the closure of the air proving switch. The heat section has a combustion air-proving switch. This switch must close before the ignition sequence can initiate. If the air-proving switch is closed after the 30 second prepurge the ignition control will energize the spark igniter and open the gas valve.

The furnace ignition control uses flame rectification as verification of burner operation. The minimum allowable flame current for operation is 0.7 DC microamps.

If the furnace ignition control does not prove flame in 7 seconds, it will turn off the spark signal and close the gas valve. It will wait 30 seconds and then initiate a second ignition sequence. If flame is not proven during the second 7 second trial for ignition the control will turn off the spark signal, close the gas valve, wait 30 seconds and initiate a third ignition sequence. If flame rectification is not proven on the third try, the ignition control will lock out.

The heat section has two roll out switches mounted above the burners. The purpose of the roll out switch is to protect the gas heat section from flame roll out, flame burning outside the heat exchanger. A restriction in the heat exchanger or breach in the flue passages could result in a roll out situation. The roll out switch is a manual reset device.

The unit has two high temperature limit switches. One located at the heat exchanger vestibule panel and the other located in the area of the heat exchanger return bend. These limits are automatic reset devices. If the limit opens the ignition control will de-energize the gas valve. On staged gas heat, as soon as the limit closes the ignition control will reinitiate the ignition sequence. If the limit opens on a modulating gas heat section the Unit Controller will lockout the heat section.

The control circuit is tested in the factory to insure that all of these steps are followed, however, natural gas is not actually introduced to the system in the plant; nitrogen is used in its place.



### Post Start Checks

When a signal is received at the gas heat control module from the Unit Controller, verify:

- Combustion blower starts and runs for 30 seconds before the spark is initiated.
- Spark igniter sparks.
- Gas valve opens.
- Burners light from right to left, in a 2.5-second time frame.
- Each burner lights in sequential order from right to left; and establishes stable flame immediately upon ignition.
- No gas leaks in the unit piping as well as the supply piping.
- Correct manifold gas pressures. *See Manifold Gas Pressure Adjustment on page 50.*
- The supply pressure is adequate. It must be within the limitations shown in *Table 7 on page 49.*

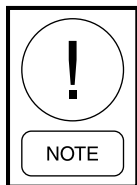

***Supply pressure should be checked with all gas appliances in the building at full fire. At no time should the standby gas pressure exceed 13.5" W.C., nor the operating pressure drop below 4.5" W.C. for natural gas or 11.0" W.C. for propane. If the gas pressure is outside these limits, contact the installing mechanical contractor for corrective action.***

- The flame is stable, with the flame present only at the end of the burner and that there isn't any burning occurring inside the burner.

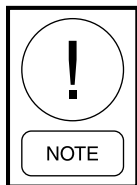

***There should be a little yellow tipping of the flame.***

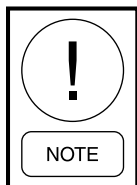

***There may be some smoke thru the flue, due to tooling oil burning off of the heat exchanger tubing.***

**TABLE 7 - LOW FIRE / HIGH FIRE PRESSURE - STAGED**

TYPE OF GAS	LINE PRESSURE		MANIFOLD PRESSURE	
	MINIMUM	MAXIMUM	LOW FIRE +/- 0.3" W.C.	HIGH FIRE +/- 0.3" W.C.
NATURAL	4.5" W.C.	13.5" W.C.	1.4" W.C.	3.5" W.C.
PROPANE	11.0" W.C.	13.5" W.C.	4.2" W.C.	10.0" W.C.

**TABLE 8 - LOW FIRE / HIGH FIRE MODULATING**

TYPE OF GAS	LINE PRESSURE		PRESSURE TO MAXITROL VALVE	
	MINIMUM	MAXIMUM	LOW FIRE +/- 0.3" W.C.	HIGH FIRE +/- 0.3" W.C.
NATURAL	4.5" W.C.	13.5" W.C.	1.4" W.C.	3.5" W.C.

### MANIFOLD PRESSURE – MODULATING GAS

**TABLE 9 - LOW FIRE (INDUCER FAN ON LOW, 1.4" W.C. INPUT TO MAXITROL VALVE)**

INPUT VOLTAGE TO SIGNAL CONDITIONER (VDC)	MANIFOLD PRESSURE ("W.C.)
0.0	0.22
0.5	0.22
1.0	0.22
1.5	0.22
2.0	0.22
2.5	0.32
3.0	0.45
3.5	0.66
4.0	0.84
4.5	1.05
5.0	1.25
5.5	1.30
6.0	1.30
6.5	1.30

**TABLE 10 - HIGH FIRE (INDUCER FAN ON HIGH, 3.5" W.C. INPUT TO MAXITROL VALVE)**

INPUT VOLTAGE TO SIGNAL CONDITIONER (VDC)	MANIFOLD PRESSURE ("W.C.)
4.0	1.10
4.5	1.40
5.0	1.70
5.5	2.10
6.0	2.50
6.5	2.90
7.0	3.15
7.5	3.25
8.0	3.30
8.5	3.30
9.0	3.30

### Manifold Gas Pressure Adjustment

Small adjustments to the manifold gas pressure can be made by following the procedure outlined below. Refer to *Figure 16 on page 50* for the high and low fire pressure regulator adjustment locations.

1. Turn the gas OFF to the unit.
2. Use a 3/16 inch Allen wrench to remove the 1/8 inch NPT plug from the outlet pressure tap of the valve.
3. Install a brass adapter to allow the connection of a hose to the outlet pressure tap of the valve.
4. Connect the hose to a manometer capable of reading the required manifold pressure value.
5. Turn the gas back ON.
6. Place the heat section into high fire operation.
7. Compare the high fire manifold pressure to *Table 7 on page 49*.
8. To adjust the high fire manifold pressure remove the cap from the high fire pressure regulator. Use a 3/32 Allen wrench to make the manifold pressure adjustment. To increase the manifold pressure, turn the screw clockwise; to decrease the manifold pressure, turn the screw counterclockwise. Place your finger over the adjustment opening while verifying the manifold pressure.
9. Place the heat section into low fire operation.
10. Compare the low fire manifold pressure to *Table 7 on page 49*.

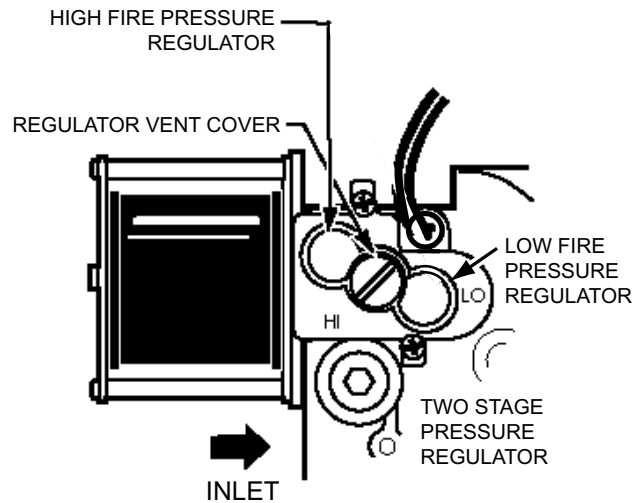

**FIGURE 16 - MANIFOLD GAS PRESSURE ADJUSTMENT**

11. To adjust the low fire manifold pressure remove the cap from the low fire pressure regulator. Use a 3/32 inch Allen wrench to make the manifold pressure adjustment. To increase the manifold pressure, turn the screw clockwise; to decrease the manifold pressure, turn the screw counterclockwise. Place your finger over the adjustment opening while verifying the manifold pressure.
12. Turn the heat OFF.
13. Turn the gas OFF.
14. Remove the brass tubing adapter and replace the plug in the outlet pressure tap.

**TABLE 11 - GAS HEAT PERFORMANCE DATA**

UNIT	GAS INPUT CAPACITY (BTU/HR X 1000)	MAXIMUM OUTPUT CAPACITY (BTU/HR X 1000)	AIRFLOW		TEMP. RISE (°F)
			MIN.	MAX.	
70-85	375	300	6,950	27,750	10-40
	750	600	11,150	27,750	20-50
	1125	900	15,150	33,325	25-55
90-105	375	300	6,950	27,750	10-40
	750	600	11,150	27,750	20-50
	1125	900	15,150	33,325	25-55

## SECTION 4 – MAINTENANCE



***Make sure power is removed from the unit before performing the maintenance items contained in this section of the manual.***

### GENERAL

A planned program of regularly scheduled maintenance will return dividends by averting possible costly and unexpected periods of down time. It is the responsibility of the owner to provide the necessary maintenance for the air handling units and coils. If a system failure occurs due to improper maintenance during the warranty period, Johnson Controls will not be liable for costs incurred to return the unit to satisfactory operation.

### PERIODIC MAINTENANCE – MONTHLY

#### Filters

Check the cleanliness of the filters and replace or clean as required.

#### Linkages

Examine the damper and operator linkages to insure that each is free and operating smoothly.

#### Compressors

**Oil Level Check:** The oil level can only be tested when the compressor is running in stabilized conditions, to ensure that there is no liquid refrigerant in the lower shell of the compressor. When the compressor is running in stabilized conditions, the oil level must be between 1/4 and 3/4 in the oil sight glass. Note: at shutdown, the oil level can fall to the bottom limit of the oil sight glass.

**Oil Analysis:** Use YORK Type “T” POE oil (clear) for units charged with R-410a refrigerant. The type of refrigerant and amount per system is listed on the unit rating plate. A change in the oil color or odor may be an indication of contaminants in the refrigeration system. If this occurs, an oil sample should be taken and analyzed. If contaminations are present, the system must be cleaned to prevent compressor failure. This can be accomplished through the installation of oversized suction and liquid line driers. The driers may have to be changed several times to clean up the system depending on the degree of contamination.



***Never use the scroll compressor to pump the refrigerant system down into a vacuum. Doing so will cause internal arcing of the compressor motor, which will result in failure of compressor.***

#### Fan Bearing Lubrication

Add grease slowly with shaft rotating until a slight bead forms at the seals. If necessary, re-lubricate while bearing is stationary. The fan data plate (attached to the fan scroll) lists the type of grease that must be used for lubricating the bearings. Refer to *Table 12 on page 51* for lubricating schedule.

Re-lubrication is generally accompanied by a temporary rise in operating temperature. Excess grease will be purged at seals.

**TABLE 12 - FAN BEARING – LUBRICATION INTERVALS**

RELUBRICATION SCHEDULE (MONTHS) BALL BEARING PILLOW BLOCKS									
SPEED (RPM)	500	1000	1500	2000	2500	3000	3500	4000	4500
Shaft Dia									
1/2” thru 1-11/16”	6	6	5	3	3	2	2	2	1
1-15/16” thru 2-7/16”	6	5	4	2	2	1	1/2	1/4	1/4
2-11/16” thru 2-15/16”	5	4	3	2	1	1/2	1/2		
3-7/16” thru 3-15/16”	4	3	2	1	1/2	1/2			

## Recommended Lubricant for Fan Bearings

A Lithium / Petroleum base grease conforming to an NLGI Grade II consistency is normally used. Lubricant must be free of any chemical impurities such as free acid or free alkali, dust, rust, metal particles or abrasive. This light viscosity, low torque grease is rust inhibited and water resistant, has a temperature range of -30 °F to +200 °F with intermittent highs of +250 °F. Lubricate bearings as required by the severity of required duty.

## Condenser Coils

Dirt should not be allowed to accumulate on the condenser coil surfaces. Cleaning should be as often as necessary to keep coil clean.

If the coil needs to be cleaned, it should be washed with water or with non-acidic Calgon Coilclean (mix one part Coilclean with seven parts water). Allow the Coilclean solution to remain on the coil for 30 minutes before rinsing with water. The solution should not be allowed to come into contact with painted surfaces. Do not use pressurized water greater than that found in common garden hose/pressure nozzle equipment. Use of a high pressure power washer to clean the coil will damage the coil and could result in poor system performance or system failure.

## PERIODIC MAINTENANCE – THREE TO SIX MONTHS



***Disconnect and lock-out power from the unit anytime service is being performed on the fan section. Failure to do so could result in serious injury or death due to the fan turning ON while work is in progress.***



***Squealing belts during starting is caused by slipping belts that are not tensioned properly.***

## Motor Bearing Lubrication

Bearings must be re-lubricated periodically to assure long life. Motor bearing should be lubricated yearly, but may need lubrication more frequently, depending on severe operating conditions.

## Belt Tension

Adjust the belt tension if necessary. Required belt tension data is supplied on the fan “skid” data plate, attached to the fan housing. Never use a belt dressing on the belts. If belts slip with the proper tension, use a good grade of belt cleanser to clean the belts. Refer to *Figure 17 on page 52*.

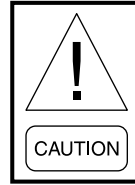

***Never use excessive belt tension, as this could result in damaging the bearing, motor pulleys or motor base. See drive label on fan housing adjacent to drive for specific details on tension.***

When it is necessary to replace one belt in a given set, the entire set of belts must be replaced.

## PERIODIC MAINTENANCE – YEARLY

Check the fan wheels and inspect the drain pan for sludge and foreign material. Clean if required.

Observe the operation of all dampers and make any necessary adjustments in linkage and blade orientation for proper operation.

## Entire Unit Inspection

In addition to the checks listed in this section of the manual, periodic overall inspections of the unit should be accomplished to ensure proper equipment operation. Items such as loose hardware, component operation, refrigerant leaks, unusual noises, etc. should be investigated and corrected immediately.

## Sheave Alignment

To check sheave alignment, a straight edge or a piece of string can be used. If the sheaves are properly aligned, the string or straight edge will touch at all points, as indicated in *Figure 17 on page 52*. Rotating the sheaves will determine if the sheave is wobbly or the drive shaft is bent. Alignment error must be corrected to avoid bearing and belt failure.

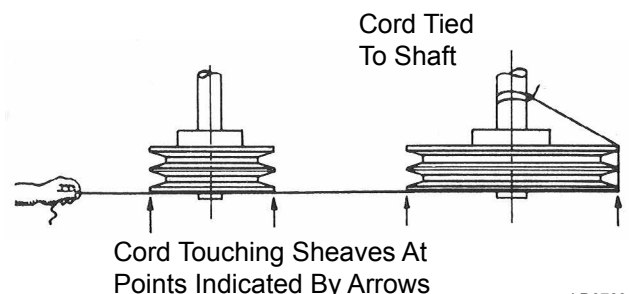

**FIGURE 17 - SHEAVE ALIGNMENT**

LD07634

## Belts

New belts should be re-checked after 24 hours of operation. On multiple belt adjustable pulleys, the pitch depth should be checked to insure identical belt travel, power transfer and wear. Adjustable motor bases are provided for belt adjustment.

Motor pulleys and blower shaft pulleys are locked in position with either set screws or split taper lock bushings. All set screws and/or taper lock bolts must be checked for tightness and alignment before putting equipment into operation.

An incorrectly aligned and tensioned belt can substantially shorten belt life or overload blower and motor bearings, shortening their life expectancy. A belt tensioned too tightly can overload the motor electrical, causing nuisance tripping of the motor overloads and/or motor failure and/or shaft failure.

## Belt Replacement

Always replace belts as a set. Follow the steps below to replace belts:

1. Release the tension on the belts by loosening the adjusting nuts on the fan motor.
2. Remove old belts and recheck the sheave alignment with a straight edge.
3. Install the new belts on the sheaves.

Never place the belts on the sheaves by using a screwdriver to pry the belt over the rim of the sheave. This will permanently damage the belts.

## Belt Tensioning

Belt tension information is included on the fan skid data plate as shown in *Figure 18 on page 53*. Sample data plate shows 4.3 lbs pressure at .30-inches deflection.

A Browning Belt tension gauge is used in *Figure 19 on page 53* to properly tension belts.

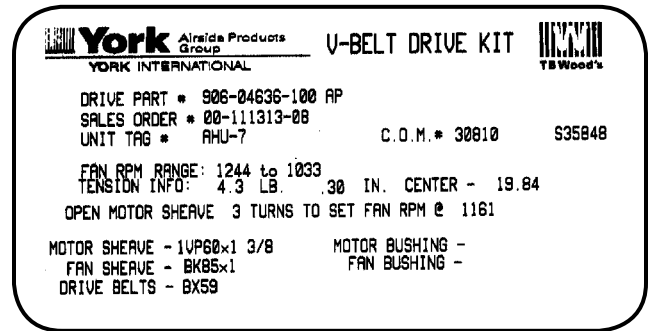

00494vip

FIGURE 18 - FAN DATA PLATE - BELT TENSION

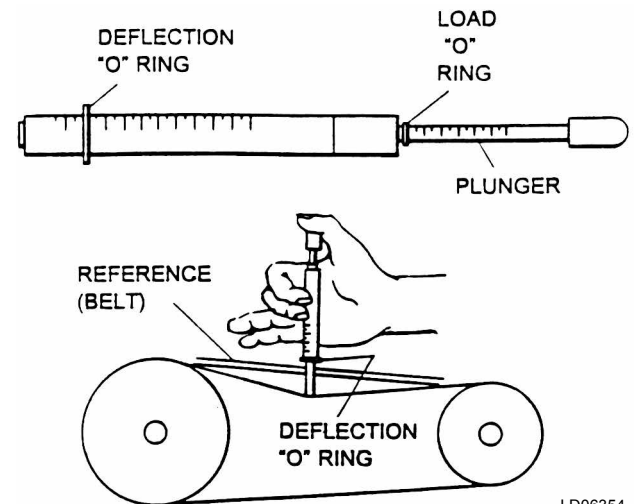

LD06354

FIGURE 19 - BELT TENSIONING GAUGE

## Filter Drier Replacement

The filter/drier should be replaced any time work is performed on the refrigerant circuit. The rooftop unit comes with sealed type (non-replaceable) cores as standard. If the unit is not equipped with the optional valve package (suction, discharge, and liquid line valves); the refrigerant will need to be recovered with a recovery machine to replace the filter/drier.

If the unit is equipped with a valve package, the unit can be pumped down by closing the liquid line ball valve (prior to the filter/drier) while the unit is running, initiating a unit pump-down. The unit will shut off when the mechanical low-pressure switch opens. When the unit shuts down, close the ball valve located after the filter/drier and remove power from the unit to prevent the unit from running. Once the filter/drier core has been replaced, the filter/drier section should be evacuated via the Schrader access valve located next to the filter/drier prior to opening the ball valves and restoring the unit to normal operation.



***Never shut the discharge valve while the unit is running. Doing so could cause a rupture in the discharge line or components, resulting in death or serious injury.***



***Never close the suction line ball valve with the compressor running. Doing so will cause the compressor to pump-down into a vacuum and damage the compressor due to internal arcing.***

## Forward Curved Fans

The forward curved fan wheel must be removed through the fan discharge opening. The location of other clamps, fan wheel, and shaft must be marked so each of these components can be reassembled in the same location (see *Figure 20 on page 54*). This will preserve the balance of the rotating assembly. Proceed with the following steps:

1. Disconnect all duct work or guards attached to the blower housing to permit unobstructed access.
2. Remove the cut off plate attached at the discharge or blast area of the blower housing.
3. Thoroughly clean the shaft of all grease and rust inhibitor. Be careful not to contaminate the bearing grease. Use emery cloth to remove all rust or the wheel may become “locked” to the shaft.

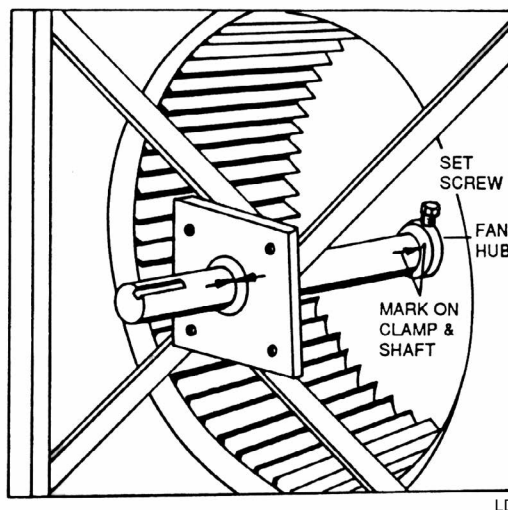

**FIGURE 20 - EXAMPLE OF FC FAN SHAFT/WHEEL MARKING**

4. Loosen and remove set screws on both bearing locking collars. Inspect and, if necessary, replace.
5. Loosen and remove set screws from both sides of the wheel hub. Inspect and, if necessary, replace.
6. Using a rubber mallet or brass bar, slowly drive the shaft in one direction until the set screw marks on the shaft are fully exposed. File the marks completely smooth. Drive the shaft in the opposite direction and file smooth the set screw marks. Continue to clean the shaft of all dirt and residuals.
7. To remove the key, use a rubber mallet or brass bar to drive the shaft and wheel in one direction. Drive the key in the opposite direction using a nail set or smaller size key stock until the key is completely free of the wheel. Be sure that key does not get bent by allowing it to ride up the key way edge. The slightest bend will prevent quick assembly. Should this occur, replace the key stock.
8. Remove the shaft, supporting the weight of the wheel, particularly for larger diameter wheels. Do not allow the weight of the shaft to be supported by one bearing as you disassemble.
9. Remove the wheel through the discharge or outlet area of the blower housing.
10. Reassemble in reverse order, centering the wheel between the edges of the inlet venturi. If bearings were removed or replaced, be sure to reuse any shim stock found between the mounting support/plate and bearing housings.
11. Torque all hardware.



***Disconnect and lock-out power from the unit anytime service is being performed on the fan section. Failure to do so could result in serious injury or death due to the fan turning ON while work is in progress.***

### Fan Motor

1. Shut OFF unit power and lock out.
2. Disconnect and tag power wires at motor terminals.
3. Loosen motor base-to-mounting-rail attaching bolts.
4. Mark belt as to position. Remove and set aside belts.
5. Remove motor bracket hold down bolts.
6. Remove motor pulley and set aside.
7. Remove motor.
8. Install new motor. Reassemble by reversing steps 1 thru 6. Be sure to reinstall multiple belts in their original position. Use a complete new set if required. Do not stretch belts over sheaves. Review the sections on motor and sheave installation, sheave alignment, and belt tensioning discussed previously in this manual.
9. Reconnect motor leads and restore power. Check fan for proper rotation as described in Start-Up Check List.

### Fan Shaft Bearings

**General** – When removing and replacing the bearings, care should be taken to ensure that the area where the bearings fit on the shaft does not become scored or damaged. The shaft in this area should be thoroughly cleaned before the bearing is removed and again before the new bearing is installed.

### Mounting Details

1. Check the shaft. It should be straight, free of burrs and full size. Be sure the bearing is not seated on a worn section of shafting.
2. Make certain any set screws are not obstructing the bearing bore.
3. Align the bearing in its housing and slide the bearing into position on shaft (never hammer the ends of the inner race). If necessary, use a brass bar or pipe against the inner race to drift bearing into place (never hit the housing, as bearing damage may result). Make sure there is lubricant between the bearing outer ring and the housing.
4. Fasten the bearing housing to the unit mounting support with hex head cap screws, washers, new lock washers and hex nuts before securing the bearing to the shaft. This permits the bearing to align itself in position along the shaft and eliminates any possibility of cramping loads.
5. Rotate the shaft to make certain it turns freely.
6. Bearings may employ one of several different methods to lock the bearing to the shaft.

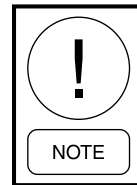

***Shaft should be free from burrs. If old shaft is used, be sure a ball bearing is not seated on worn section and shaft is not bent.***

There are various degrees of self-alignment in bearings of the same manufacturer. The force required for the self-alignment of the bearings used in YORK manufactured units has been specified and is closely monitored at the factory. If it is necessary to purchase a bearing locally, be sure it can be worked around in the housing with a short shaft made of wood or other soft material placed in the bearing.

Prior to installing the bearing on the shaft, it should be worked around in the housing to make sure that self-alignment will be obtained where the bearing is installed. After the shaft journal has been inspected for cleanliness, metal chips or burrs, the bearing is slipped, not forced, onto the shaft. Forcing the bearing onto the shaft by the use of flange, pillow block, or outer ring will damage the bearing internally. Force applied in this way transmits the load to the inner race through the balls in the bearing. Since the bearings are not designed for axial loading, the sides of the races in which the balls turn can be damaged. If the bearing cannot be made to slip onto the shaft by pressing on the inner ring of the bearing, check the shaft for burrs. Install the bearing so the part of the inner race, which receives the locking collar or contains setscrews, is toward the outside of the unit.

If the grease fitting must be changed on bearings that utilize a locking pin under the fitting, it is important to properly replace it. If an adapter or grease fitting of improper size and length is used, the locking pin may be either too tight or loose and can affect the alignment and re-lubrication of the bearing.

### Bearing Lock Devices

Various types of locking devices are used to secure bearing(s) to the fan shaft. Refer to the instructions packed with bearings for special information. Figure 21 on page 56 is a typical bearing with a setscrew-type locking device. The various locking devices can be classified under basic types: eccentric locking type, concentric locking type, and Skwezloc type.

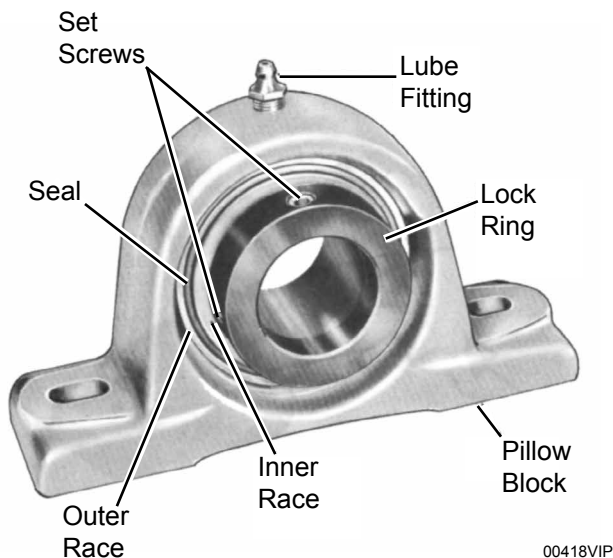

**FIGURE 21 - BEARING WITH SETSCREW TYPE LOCKING DEVICE**

### Eccentric Type

An eccentric self-locking collar is turned and driven with a punch in the direction of shaft rotation to lock the bearing inner ring to the shaft. See Figure 23 on page 57.

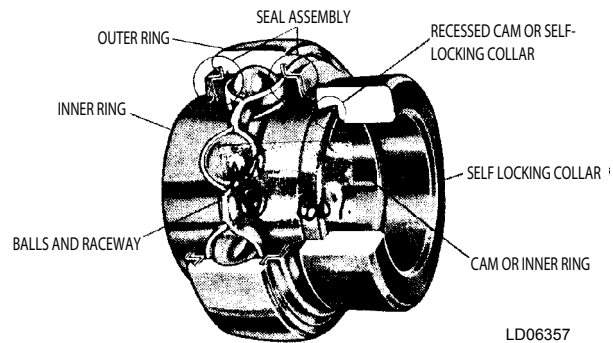

**FIGURE 22 - BEARING WITH ECCENTRIC CAM**

When the eccentric collar is engaged to the cam on the bearing inner ring and turned in direction of rotation, it grips the shaft with a positive binding action. The collar is then locked in place with the setscrew provided in the collar.

The self-locking collar is placed on the shaft with its cam adjacent to the cam on the end of the bearing's wide inner ring. In this position, with collar and bearing cams disengaged, the collar's bore is concentric with that of the bearing's inner ring. The wide inner ring is loose on the shaft. By turning the collar in the direction of normal shaft rotation, the eccentric recessed cam will drop over and engage with the corresponding cam on the bearing inner, causing it to grip the shaft tightly with a positive binding action. See Figure 23 on page 57 and Figure 24 on page 57. Make sure the two cams engage smoothly and the locking collar is down flat against the shoulder of the inner ring. The wide inner ring is now locked to the shaft. Using a punch or similar tool in the drilled hole of the collar, tap the tool lightly to lock the collar in the direction of normal shaft rotation.

As a final step, the setscrew is tightened. Torque per Table 13 on page 57. It exerts a wedging action to hold the collar always in the engaged position, even under shock and reversing loads.

To disassemble, loosen the setscrew and tap the collar in the direction opposite shaft rotation.



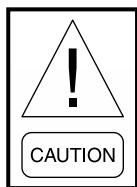
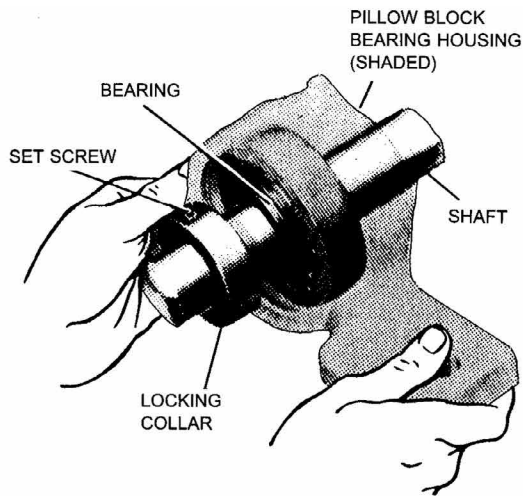

**Do not apply excessive force to the bearing housing (pillow block or flange) when installing the bearing on the shaft.**

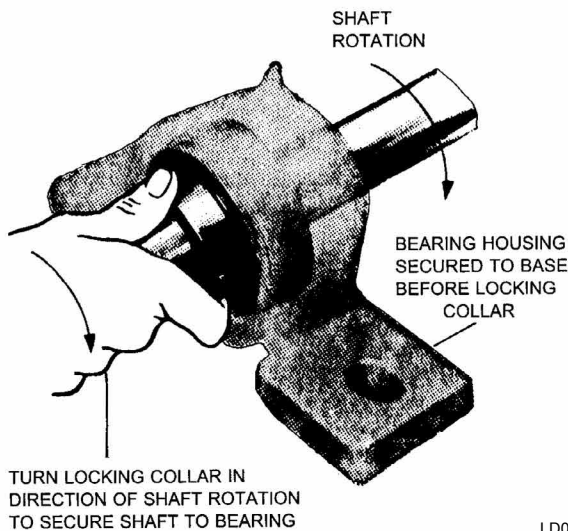

LD06358

**FIGURE 23 - ECCENTRIC CAM LOCKING COLLAR BEARING INSTALLATION**

**TABLE 13 - SET SCREW TORQUE**

SET SCREW DIA.	HEX. SIZE ACROSS FLATS LBS.	MIN. RECOMMENDED TORQUE	
		INCH LBS.	FOOT LBS.
1/4 1/8	66 - 85	5.5 - 7.2	
5/16	5/32	126 - 164	10.5 - 13.7
3/8 3/16	228 - 296	19.0 - 24.7	
7/16	7/32	348 - 452	29.0 - 37.7
1/2 1/4	504 - 655	42.0 - 54.6	
5/8 5/16	1104 - 1435	92.0 - 119.6	

**Torquing of Set-screws**

1. Torque screw "A" to 1/2 recommended torque.
2. Torque screw "B" to full min. recommended value.
3. Torque screw "A" to full recommended value.



**After proper installation of the bearing(s), run the unit for 10 to 15 minutes. Shut the unit down and lock it out. Check for proper engagement of locking collar and tightness of set screw(s).**

When replacing split bearings, refer to manufacturer's instruction provided with the bearing. It is extremely important to ensure that proper radial clearances are observed between the roller bearings and outer face. Failure to make proper adjustments will cause premature failure of the bearing.

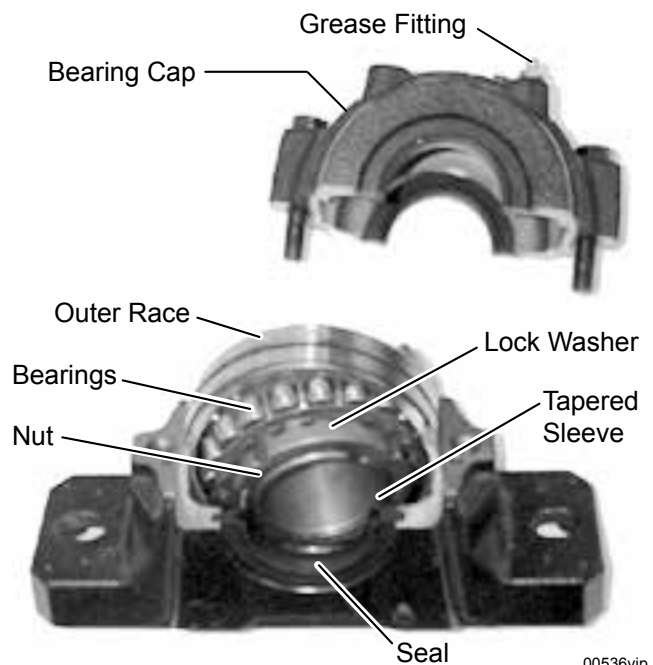

00536vip

**FIGURE 24 - SPLIT BEARING**

THIS PAGE INTENTIONALLY LEFT BLANK

## SECTION 5 – SEQUENCE OF OPERATION

### UNIT TYPE

The Unit Controller is capable of being programmed for three different “UNIT TYPE” which establish the mode of operation. The “UNIT TYPE” is set through the OPTIONS key, UNIT DATA subsection of the User Interface. The four options are:

- “CONSTANT VOLUME”
- “VARIABLE AIR VOLUM”
- “FLEXSYS”
- “SZVAV”

### CURRENT OPER MODE

The “CURRENT OPER MODE”, occupied or unoccupied, is a derived value and can be established in three ways:

- Digital Input “OCCUPANCY STATE” ON/OFF input – “ON” occupied / “OFF” unoccupied. The Digital input is made through a connection between “24V” and “OCC” on the unit field low voltage terminal block.
- Serial Input “OCCUPANCY COMMAND” usually originates from a BAS system.
- Internal Time Clock “OCCUPANCY SCHEDULE” the internal clock can be turned ON and OFF through the SCHEDULE key of the User Interface. The occupied / unoccupied schedule can be programmed through the SCHEDULE key of the User Interface.

Within the “CURRENT OPER MODE” are twenty sub-modes of operation:

- “OCCUPIED COOLING”
- “OCC COOLING LOW”
- “OCC COOLING HIGH”
- “OCC COOLING W/ BYP”
- “OCC COOLING W/O BYP”
- “OCCUPIED HEATING”
- “OCC HEATING LOW”
- “OCC HEATING HIGH”
- “OCCUPIED STANDBY”

- “UNOCCUPIED COOLING”
- “UNOC COOLING LOW”
- “UNOC COOLING HIGH”
- “UNOCCUPIED HEATING”
- “UNOC HEATING LOW”
- “UNOC HEATING HIGH”
- “UNOCCUPIED STANDBY”
- “COMFORT VENT COOLING”
- “COMFORT VENT HEATING”
- “MORNING WARM UP”
- “UNDER FLOOR TEMP OVERRIDE”

The “CURRENT OPER MODE” can be viewed at the STATUS screen.

The operation of the unit in each of the above modes of operation will be defined later in this manual.

The Unit Controller monitors the switching from the standby mode to an active cooling or heating mode. The unit must be in the standby mode for 3 minutes before the control will allow it to switch to an active heating or cooling mode.

The Unit Controller also monitors the switching between the active cooling and heating modes. The unit must remain in one of the active heating or cooling modes for 30 seconds before it can be turned OFF or switched.

### Constant Volume Mode

A “CONSTANT VOLUME” unit will be controlled by one of three “CONTROL METHOD”:

- “STAGED” (Thermostat)
- “WIRED ZONE TEMP” (Hardwired)
- “COMM ZONE TEMP” (Communicated)

The “CONTROL METHOD” is entered into the Unit Controller through the OPTIONS key, UNIT DATA subsection of the User Interface.

**TABLE 14 - DIGITAL INPUTS FOR STAGED INPUT STAGED INPUT MODE**

Y1 LOW COOL	Y2 HIGH COOL	W1 LOW HEAT	W2 HIGH HEAT	CURRENT OPER MODE	UNIT MODE
On	Off	Off	Off	Occupied	Occupied Cooling Low
On/Off	On	Off	Off	Occupied	Occupied Cooling High
Off	Off	On	Off	Occupied	Occupied Heating Low
Off	Off	On/Off	On	Occupied	Occupied Heating High
Off	Off	Off	Off	Occupied	Occupied Standby (See Also Comfort Ventilation Operation)
On	Off	Off	Off	Unoccupied	Unoccupied Cooling Low
On/Off	On	Off	Off	Unoccupied	Unoccupied Cooling High
Off	Off	On	Off	Unoccupied	Unoccupied Heating Low
Off	Off	On/Off	On	Unoccupied	Unoccupied Heating High
Off	Off	Off	Off	Unoccupied	Unoccupied Standby

### Staged Input

The unit requires the following digital inputs in order to operate in the “*STAGED*” mode of operation. The inputs are made at the low voltage terminal block of the unit.

- W1 LOW HEAT - terminal 12 of CTB1
- W2 HIGH HEAT - terminal 13 of CTB1
- Y1 LOW COOL - terminal 10 of CTB1
- Y2 HIGH COOL - terminal 11 of CTB1

Table 14 on page 60 shows what the Unit Mode would be based on the digital inputs.

### VARIABLE AIR VOLUME MODE

#### Occupied Cooling

In the OCCUPIED COOLING mode the Unit Controller monitors the “*RETURN AIR TEMP*” and compares it to the “*RAT COOLING SETPOINT*” setpoint. The “*RAT COOLING SETPOINT*” setpoint is entered into the Unit Controller through the SETPOINTS key, COOLING subsection of the User Interface. If the “*RETURN AIR TEMP*” is equal to or greater than the “*RAT COOLING SETPOINT*” setpoint plus 0.5 °F, the Unit Controller will place the unit in the OCCUPIED COOLING mode.

The unit will remain in the OCCUPIED COOLING mode until the “*RETURN AIR TEMP*” is equal to or less than the “*RAT COOLING SETPOINT*” setpoint minus 0.5 °F.

#### Occupied Heating

In the OCCUPIED HEATING mode, the Unit Controller monitors the “*RETURN AIR TEMP*” and compares it to the “*RAT HEATING SETPOINT*” setpoint.

The “*RAT HEATING SETPOINT*” setpoint is entered into the Unit Controller through the SETPOINTS key, HEATING subsection of the User Interface. If the “*RETURN AIR TEMP*” is equal to or LESS than the “*RAT HEATING SETPOINT*” setpoint minus 0.5 °F, the Unit Controller will place the unit in the OCCUPIED HEATING mode.

The unit will remain in the OCCUPIED HEATING mode until the “*RETURN AIR TEMP*” is equal to or greater than the “*RAT HEATING SETPOINT*” setpoint plus 0.5 °F.

#### Unoccupied Cooling

In the UNOCCUPIED COOLING mode, the Unit Controller will monitor the “*ZONE TEMP*” and compare it to the “*UNOCC ZONE COOLING SETPOINT*.” The “*UNOCC ZONE COOLING SETPOINT*” is set through the SETPOINTS key, COOLING subsection of the User Interface. If the “*ZONE TEMP*” is equal to or greater than the “*UNOCC ZONE COOLING SETPOINT*” temperature plus 0.5 °F, the Unit Controller will place the unit in the UNOCCUPIED COOLING mode.

The unit will remain in the UNOCCUPIED COOLING mode until the “*ZONE TEMP*” is equal to or less than the “*UNOCC ZONE COOLING SETPOINT*” setpoint minus 0.5 °F.

#### Unoccupied Heating

In order for the UNOCCUPIED HEATING to function, the “*NIGHT SET BACK*” setting must be set to ENABLE. This can be done through the PROGRAM key, HEATING subsection of the User Interface.

In the UNOCCUPIED HEATING mode the Unit Controller will monitor the “*ZONE TEMP*” and compare

it to the “UNOCC ZONE HEATING SETPOINT.” The “UNOCC ZONE HEATING SETPOINT” is set through the SETPOINTS key, HEATING subsection of the User Interface. If “ZONE TEMP” is equal to or less than the “UNOCC ZONE HEATING SETPOINT” minus 0.5 °F, the Unit Controller will place the unit in the UNOCCUPIED HEATING mode.

The unit will remain in the UNOCCUPIED HEATING mode until the “ZONE TEMP” is equal to or greater than the “UNOCC ZONE HEATING SETPOINT” plus 0.5 °F.

**SINGLE ZONE VAV MODE**

Units configured for Single Zone VAV operation shall contain a supply fan variable frequency drive. The unit shall switch between cooling mode, heating mode, and standby mode based on zone temperature. In cooling mode, the supply fan speed shall be varied based on zone temperature. If the zone temperature gets warmer, the supply fan speed shall increase. Conversely, if the zone temperature gets cooler, the supply fan speed shall decrease. In heating mode, the supply fan shall run at full speed. When the zone temperature is satisfied, the unit is neither in cooling mode nor heating mode, and the supply fan shall run at minimum speed. Control of cooling and heating stages shall operate in the same manner as a Constant Volume unit with *Unit Mode Determination*, as described in the following section.

**Unit Mode Determination**

(Hardwired or Communicated)

The unit compares the analog “WIRED ZONE TEMP” or “COMM ZONE TEMP” input to the “OCC ZONE COOLING,” “OCC ZONE HEATING,” “UNOCC ZONE COOLING,” or “UNOCC ZONE HEATING” setpoints to determine the sub-mode of operation. The following parameters must be programmed through the User Interface:

- “OCC ZONE COOLING SETPOINT” – SETPOINTS key / COOLING subsection
- “UNOCC ZONE COOLING SETPOINT” – SETPOINTS key / COOLING subsection
- “OCC ZONE HEATING SETPOINT” – SETPOINTS key / HEATING subsection
- “UNOCC ZONE HEATING SETPOINT” – SETPOINTS key / HEATING subsection

Figure 25 on page 61 shows what the UNIT MODE would be based on the difference between the zone temperature and the zone temperature setpoints.

The only difference between Hardwired and Communicated is the method the Unit Controller uses to determine the “ZONE TEMP”. In the Hardwired mode the input is an analog input to the control. In the Communicated mode the input is a serial input from a BAS control system.

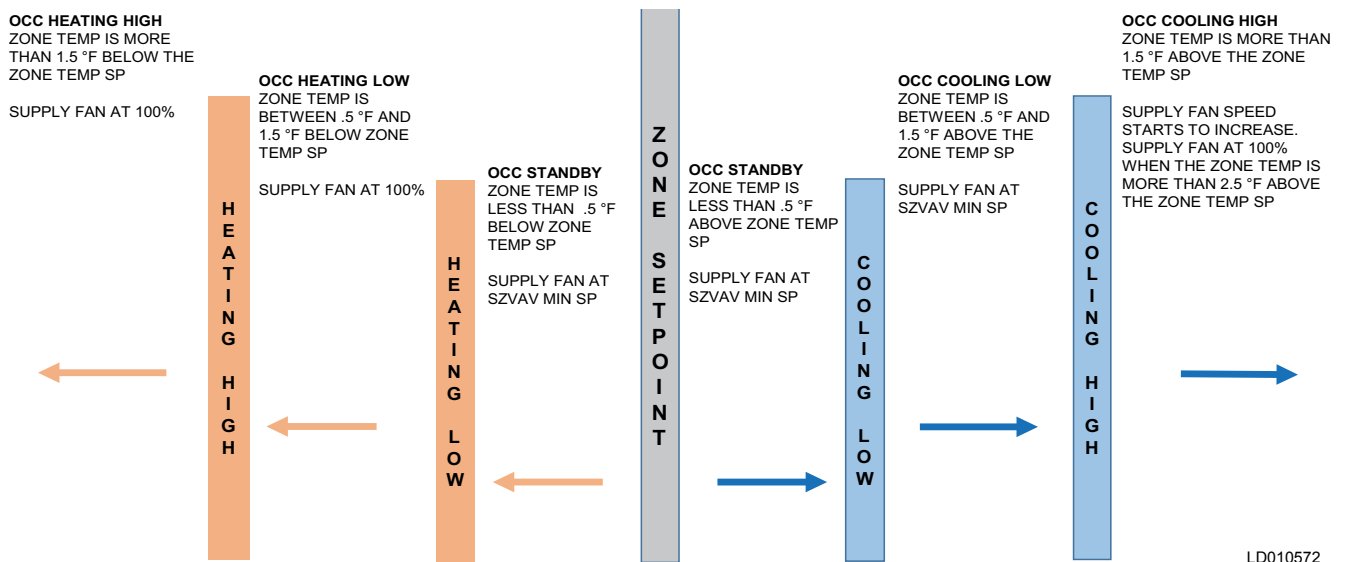

NOTES:  
 1- WHENEVER THE UNIT ENTERS AN ACTIVE COOLING OR HEATING MODE, THE UNIT CONTROLLER WILL UTILIZE AS MANY OR AS FEW STAGES OF COOLING or HEATING THAT IT NEEDS TO ACHIEVE AND MAINTAIN THE ACTIVE SUPPLY AIR TEMP SP.  
 2- UNOCCUPIED SEQUENCE WILL BE THE SAME AS ABOVE EXCEPT THE ZONE TEMP SPs USED WILL BE THE UNOCC SP's VALUES.  
 3- UNIT MODES WILL STAGE DOWN WHEN THE ZONE TEMP IS .5 °F UNDER SPs FOR COOLING AND .5 °F OVER SPs FOR HEATING.

**FIGURE 25 - OPERATIONAL MODE : SINGLE ZONE VAV**

## Supply Air Temp Active Setpoint Determination

When the “CONTROL METHOD” is set to Zone Temperature Control (either hardwired or communicated), the “SUPPLY AIR TEMP ACTIVE SP” is determined by the difference between the “ZONE TEMP” and the appropriate zone setpoint. Table 15 on page 62 shows the parameters that are used to determine the “SUPPLY AIR TEMP ACTIVE SP”:

Where:

- $\Delta T_{OC} = \text{“ZONE TEMP”} - \text{“OCC ZONE COOLING SETPOINT”}$
- $\Delta T_{OH} = \text{“ZONE TEMP”} - \text{“OCC ZONE HEATING SETPOINT”}$
- $\Delta T_{UC} = \text{“ZONE TEMP”} - \text{“UNOCC ZONE COOLING SETPOINT”}$
- $\Delta T_{UH} = \text{“ZONE TEMP”} - \text{“UNOCC ZONE HEATING SETPOINT”}$

**TABLE 15 - ACTIVE SAT SETPOINT DETERMINATION, ZONE TEMPERATURE**

$\Delta T_{OC}$ OCC COOL	$\Delta T_{OH}$ OCC HEAT	$\Delta T_{UC}$ UNOCC COOL	$\Delta T_{UH}$ UNOCC HEAT	OCCUPANCY MODE	UNIT MODE	ACTIVE SP
> 0.5 °F	---	---	---	Occupied	Occupied Cooling Low	1st Stage Cooling Setpoint
> 1.5 °F	---	---	---	Occupied	Occupied Cooling High	2nd Stage Cooling Setpoint
---	< -0.5 °F	---	---	Occupied	Occupied Heating Low	1st Stage Heating Setpoint
---	< -1.5 °F	---	---	Occupied	Occupied Heating High	2nd Stage Heating Setpoint
---	---	---	---	Occupied	Occupied Standby (See Also Comfort Ventilation Operation)	None
---	---	> 0.5 °F	---	Unoccupied	Unoccupied Cooling Low	1st Stage Cooling Setpoint
---	---	> 1.5 °F	---	Unoccupied	Unoccupied Cooling High	2nd Stage Cooling Setpoint
---	---	---	< -0.5 °F	Unoccupied	Unoccupied Heating Low	1st Stage Heating Setpoint
---	---	---	< -1.5 °F	Unoccupied	Unoccupied Heating High	2nd Stage Heating Setpoint
---	---	---	---	Unoccupied	Unoccupied Standby	None

## FlexSys

A FlexSys unit is a modified VAV system. In a FlexSys system the supply air from the unit is distributed through an underfloor air distribution system. In order to temper the air, a bypass duct between the unit return and supply duct is installed in the curb, and return air is used to temper the supply air. A damper is installed in the bypass duct in order to control the amount of bypass return air.

There are two different occupied cooling modes when a unit is configured for FlexSys operation, OCCUPIED COOLING without BYPASS and OCCUPIED COOLING with BYPASS. The Unit Controller monitors the return air temperature and compares it to the “MX SUPPLY AIR TEMP SETPOINT” plus the “RETURN AIR DIFF SP.” The “RETURN AIR DIFF SP.” can be set between 2.0 and 10.0 °F through the SETPOINTS key, COOLING subsection of the User Interface. If the return air temperature is equal to or greater than the “RAT COOLING SETPOINT” plus 0.5 °F but less than the “MX SUPPLY AIR TEMP SETPOINT” plus the “RETURN AIR DIFF SP,” the unit will operate in the COOLING without BYPASS mode. If the return air temperature is equal to or greater than the “RAT COOLING SETPOINT” plus 0.5 °F but equal to or greater than the “MX SUPPLY AIR TEMP SETPOINT”

plus the “RETURN AIR DIFF SP,” the unit will operate in the COOLING with BYPASS mode.

When the unit is in the OCCUPIED COOLING without BYPASS mode, the compressors are controlled to maintain the “MX SUPPLY AIR TEMP SETPOINT.” When the unit is in the OCCUPIED COOLING with BYPASS mode, the compressors are controlled to maintain the “EVAP LEAVING AIR TEMP HIGH” or “EVAP LEAVING AIR TEMP LOW” setpoints. The “EVAP LEAVING AIR TEMP HIGH” and “EVAP LEAVING AIR TEMP LOW” setpoints are set through the SETPOINTS key, COOLING subsection of the User Interface.

## ACTIVE SETPOINT DETERMINATION

### Constant Volume

On a Constant Volume unit, the Control Method (Staged or Zone) does not have a direct effect on the control of the compressor and heating stages. Instead the input from the Staged (usually a thermostat) or Zone (hard wired or communicated) is only used to determine the “UNIT MODE.” The staging of the compressor and heating stages is always based on the “SUPPLY AIR TEMP ACTIVE SP.”

### Staged Input Control

When the “*CONTROLMETHOD*” is set to “*STAGED*,” the “*SUPPLY AIR TEMP ACTIVE SP*” is determined by the “*1ST STAGE COOLING SETPOINT*,” “*2ND STAGE COOLING SETPOINT*,” “*1ST STAGE HEATING SETPOINT*,” and “*2ND STAGE HEATING SETPOINT*” inputs. *Table 16 on page 63* shows what the setpoints would be for each staged input combination.

The “*1ST STAGE COOLING SETPOINT*” and “*2ND STAGE COOLING SETPOINT*” setpoints are programmed into the User Interface through the SETPOINTS key COOLING subsection. The “*1ST STAGE HEATING SETPOINT*” and “*2ND STAGE HEATING SETPOINT*” setpoints are programmed into the User Interface through the SETPOINTS key HEATING subsection.

**TABLE 16 - ACTIVE SAT SETPOINT DETERMINATION, STAGED INPUT**

Y1 LOW COOL	Y2 HIGH COOL	W1 LOW HEAT	W2 HIGH HEAT	OCCUPANCY MODE	UNIT MODE	ACTIVE SP
On	Off	Off	Off	Occupied	Occupied Cooling Low	1st Stage Cooling Setpoint
On/Off	On	Off	Off	Occupied	Occupied Cooling High	2nd Stage Cooling Setpoint
Off	Off	On	Off	Occupied	Occupied Heating Low	1st Stage Heating Setpoint
Off	Off	On/Off	On	Occupied	Occupied Heating High	2nd Stage Heating Setpoint
Off	Off	Off	Off	Occupied	Occupied Standby (See Also Comfort Ventilation Operation)	None
On	Off	Off	Off	Unoccupied	Unoccupied Cooling Low	1st Stage Cooling Setpoint
On/Off	On	Off	Off	Unoccupied	Unoccupied Cooling High	2nd Stage Cooling Setpoint
Off	Off	On	Off	Unoccupied	Unoccupied Heating Low	1st Stage Heating Setpoint
Off	Off	On/Off	On	Unoccupied	Unoccupied Heating High	2nd Stage Heating Setpoint
Off	Off	Off	Off	Unoccupied	Unoccupied Standby	None

### Variable Air Volume

The “*SUPPLY AIR TEMP ACTIVE SP*” is always derived from three programmed parameters: “*SAT HIGH SETPOINT*,” “*SAT LOW SETPOINT*,” and the “*SAT RESET METHOD*.” The Unit Controller determines the derived “*SUPPLY AIR TEMP ACTIVE SP*” value to use based on the reset command sent to the controller. There are four options available to select from for the reset command method. “*SAT RESET METHOD*” can be set for “*HARDWIRED*,” “*OUTSIDE AIR*,” “*RETURN AIR*,” or “*SUPPLY FAN SPEED*.” If “*HARDWIRED*” is used and no input is available, the Unit Controller will control to the “*SAT HIGH SETPOINT*.” The following parameters are programmed through the User Interface:

- “*SAT RESET METHOD*” – OPTIONS key / UNIT DATA subsection
- “*SAT LOW SETPOINT*” – SETPOINTS key / COOLING subsection
- “*SAT HIGH SETPOINT*” – SETPOINTS key / COOLING subsection
- “*OAT SETPOINT FOR LOW SAT*” - SETPOINTS key / COOLING subsection
- “*OAT SETPOINT FOR HIGH SAT*” - SETPOINTS key / COOLING subsection
- “*RAT SETPOINT FOR LOW SAT*” - SETPOINTS key / COOLING subsection
- “*RAT SETPOINT FOR HIGH SAT*” - SETPOINTS key / COOLING subsection
- “*FAN SPEED SETP FOR LOW SAT*” - SETPOINTS key / COOLING subsection
- “*FAN SPEED SETP FOR HIGH SAT*” - SETPOINTS key / COOLING subsection

**Hardwired Sat Reset**

When the “SAT RESET METHOD” is set to “HARDWIRED,” the Unit Controller monitors the “SUPPLY AIR TEMP RST.” If the “SUPPLY AIR TEMP RST” is equal to 0.00 volts, the “SUPPLY AIR TEMP ACTIVE SP” is the “SAT HIGH SETPOINT.” If the “SUPPLY AIR TEMP RST” is equal to 5.00 volts, the “ACTIVE SP” is the “SAT LOW SETPOINT.” When the “SUPPLY AIR TEMP RST” is between 0.00 and 5.00 volts, the “SUPPLY AIR TEMP ACTIVE SP” is linearly interpolated between the “SAT HIGH SETPOINT” and the “SAT LOW SETPOINT” (see Figure 26 on page 64).

**Outside Air Based Sat Reset**

When the “SAT RESET METHOD” is set to “OUTSIDE AIR,” the Unit Controller monitors the “OUTSIDE AIR TEMP” and sets the “SUPPLY AIR TEMP ACTIVE SP” to a value between the “SAT HIGH SETPOINT” and the “SAT LOW SETPOINT.” If the “OUTSIDE AIR TEMP” is equal to or less than the “OAT SETPOINT FOR HIGH SAT,” the “SUPPLY AIR TEMP ACTIVE SP” is the “SAT HIGH SETPOINT.” If the “OUTSIDE AIR TEMP” is equal to or greater than the “OAT SETPOINT FOR LOW SAT,” the “ACTIVE SAT SP” is the “SAT LOW SETPOINT.” When the “OUTSIDE AIR TEMP” is between the “OAT SETPOINT FOR HIGH SAT” and the “OAT SETPOINT FOR LOW SAT,” the “SUPPLY AIR TEMP ACTIVE SP” is linearly interpolated between the “SAT HIGH SETPOINT” and the “SAT LOW SETPOINT” (see Figure 27 on page 64).

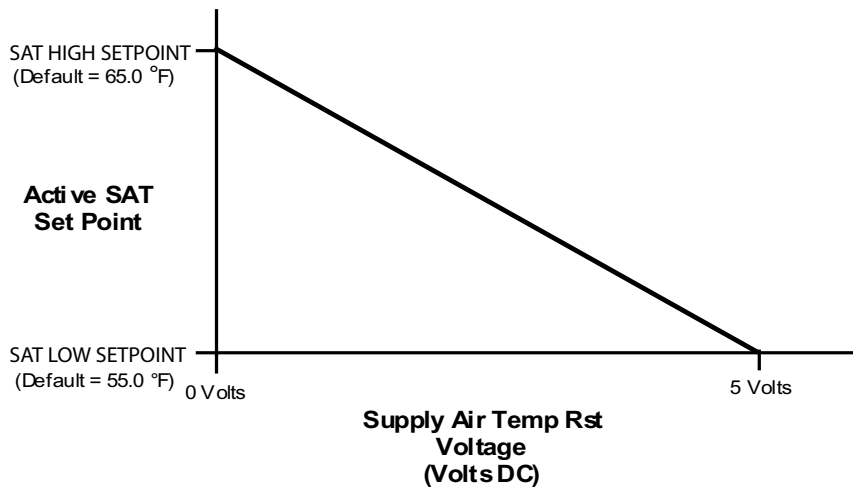

LD12587

**FIGURE 26 - ACTIVE SAT SETPOINT VS. SUPPLY AIR TEMP RST VOLTAGE**

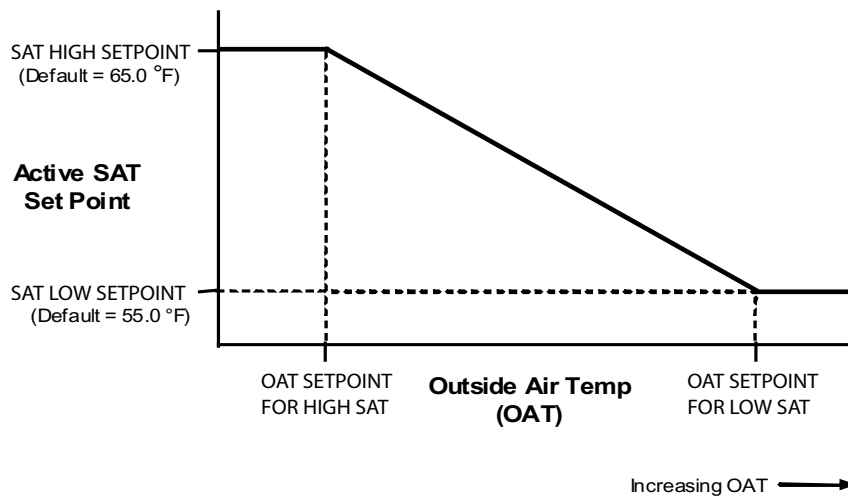

LD12588

**FIGURE 27 - ACTIVE SAT SETPOINT VS. OUTSIDE AIR TEMP**



### RETURN AIR BASED SAT RESET

When the “SAT RESET METHOD” is set to “RETURN AIR,” the Unit Controller monitors the “RETURN AIR TEMP” and sets the “SUPPLY AIR TEMP ACTIVE SP” to a value between the “SAT HIGH SETPOINT” and the “SAT LOW SETPOINT.” If the “RETURN AIR TEMP” is equal to or greater than the “RAT SETPOINT FOR LOW SAT,” the “SUPPLY AIR TEMP ACTIVE SP” shall be the “SAT LOW SETPOINT.” If the “RETURN AIR TEMP” is equal to or less than the “RAT SETPOINT FOR HIGH SAT,” the “SUPPLY AIR TEMP ACTIVE SP” shall be the “SAT HIGH SETPOINT.” When the “RETURN AIR TEMP” is between the “RAT SETPOINT FOR HIGH SAT” and the “RAT SETPOINT FOR LOW SAT,” the “SUPPLY AIR TEMP ACTIVE SP” shall be linearly interpolated between the “SAT HIGH SETPOINT” and the “SAT LOW SETPOINT” (see Figure 28 on page 65).

### Supply Fan Speed Based Sat Reset

When the “SAT RESET METHOD” is set to “SUPPLY FAN SPEED,” the Unit Controller will monitor the “SUPPLY FAN VFD SPEED” command and set the “SUPPLY AIR TEMP ACTIVE SP” to a value between the “SAT HIGH SETPOINT” and the “SAT LOW SETPOINT.” If the “SUPPLY FAN VFD SPEED” is equal to or greater than the “FAN SPEED SETP FOR LOW SAT,” the “SUPPLY AIR TEMP ACTIVE SP” shall be the “SAT LOW SETPOINT.” If the “SUPPLY FAN VFD SPEED” is equal to or less than the “FAN SPEED SETP FOR HIGH SAT,” the “SUPPLY AIR TEMP ACTIVE SP” shall be the “SAT HIGH SETPOINT.” When the “SUPPLY FAN VFD SPEED” is between the “FAN SPEED SETP FOR LOW SAT” and the “FAN SPEED SETP FOR HIGH SAT,” the “SUPPLY AIR TEMP ACTIVE SP” shall be linearly interpolated between the “SAT HIGH SETPOINT” and the “SAT LOW SETPOINT” (see Figure 29 on page 65).

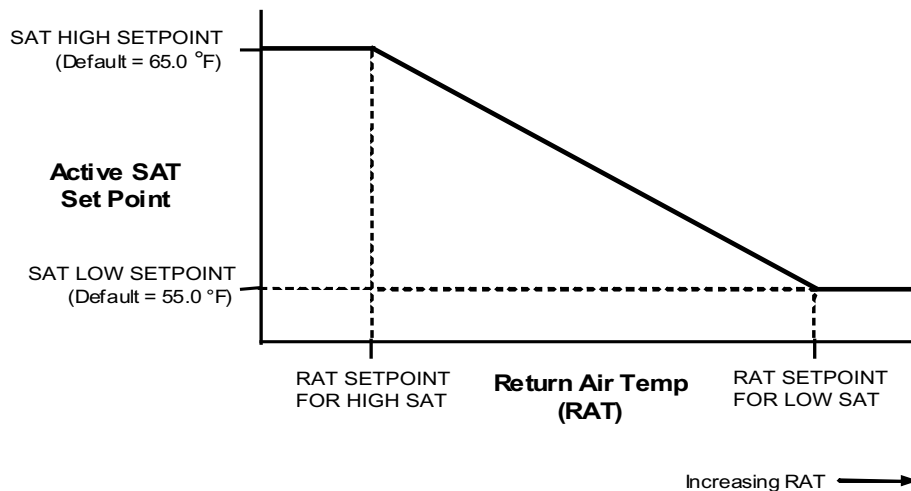

LD10307A

FIGURE 28 - ACTIVE SAT SETPOINT VS. RETURN AIR TEMP

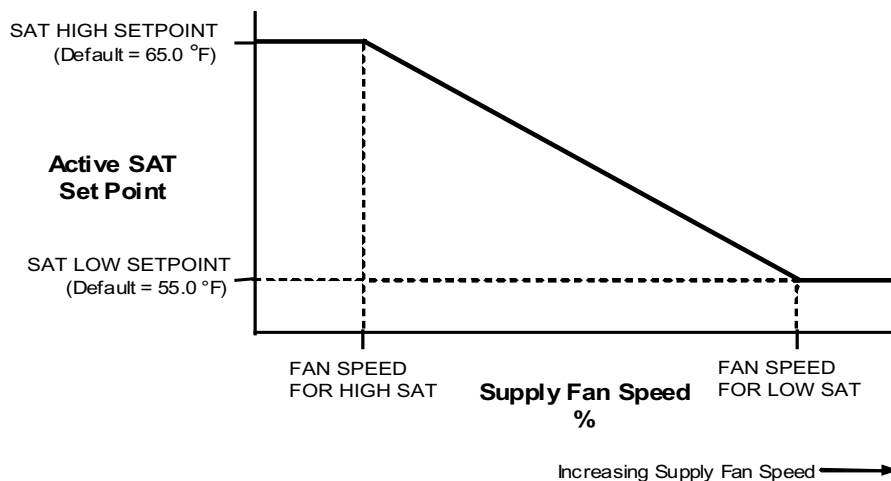

LD10308A

FIGURE 29 - ACTIVE SAT SETPOINT VS. SUPPLY FAN SPEED

**FlexSys with Bypass Damper**

The “*SUPPLY AIR TEMP ACTIVE SP*” will be the “*EVAP LEAVING AIR TEMP HIGH*” setpoint if either of the following is true:

- The Return Air Humidity sensor is not reliable.
- The Return Air Enthalpy is less than the “*RESET ENTHALPY SP*.”

The “*SUPPLY AIR TEMP ACTIVE SP*” will be the “*EVAP LEAVING AIR TEMP LOW*” setpoint if either of the following is true:

- The Return Air Enthalpy is equal to or greater than the “*RESET ENTHALPY SP*.”
- The “*UNDERFLOOR SLAB DEWPOINT*” is greater than or equal to the “*UNDERFLOOR SLAB TEMP*” minus 2.0 °F for 120 seconds.

The following parameters are programmed through the User Interface:

- “*EVAP LEAVING AIR TEMP LOW*” - SETPOINTS key / COOLING subsection.
- “*EVAP LEAVING AIR TEMP HIGH*” - SETPOINTS key / COOLING subsection.
- “*RESET ENTHALPY SP*” - SETPOINTS key / COOLING subsection.

**FlexSys without Bypass Damper**

The “*SUPPLY AIR TEMP ACTIVE SP*” is the “*MX SUPPLY AIR TEMP*”. The “*MX SUPPLY AIR TEMP*” is programmed through the SETPOINTS key / COOLING subsection of the User Interface.

**COMPRESSOR CONTROL**

Whenever a change in the unit cooling status is made (compressor turned ON, compressor turned OFF, etc.), a 3 1/2-minute Interstage Delay Timing is initiated. During the countdown of the timer no compressor can be staged ON or OFF until the timer has timed down. The only exception to this would be if the compressor protection circuit experienced a fault.

On CONSTANT VOLUME, SZVAV, and VARIABLE AIR VOLUME, when the Unit Controller enters an active cooling mode, the Unit Controller sets the “*COOLING CONTROL OFFSET*” to 2.0 °F. The Unit Controller compares the current “*SUPPLY AIR TEMP CURRENT*” to the “*SUPPLY AIR TEMP ACTIVE SP*” plus or minus the “*COOLING CONTROL OFFSET*.” If the “*SUPPLY AIR TEMP CURRENT*” is greater than the “*SUPPLY AIR TEMP ACTIVE SP*” plus the “*COOLING CONTROL OFFSET*” and all the compressors are not ON, the Unit Controller will initiate a

call for compressor or additional compressor operation based on the “*NEXT STAGE TO ENABLE*” (see Table 18 on page 70).

If the “*SUPPLY AIR TEMP CURRENT*” is less than the “*SUPPLY AIR TEMP ACTIVE SP*” minus the “*COOLING CONTROL OFFSET*” and all the compressors are not OFF, the Unit Controller will turn a compressor OFF based on the “*NEXT STAGE TO DISABLE*” (see Table 18 on page 70).

On a FLEXSYS unit with the current operating mode set to “*OCC COOLING W/O BYP*,” when the Unit Controller enters an active cooling mode, the Unit Controller sets the “*COOLING CONTROL OFFSET*” to 2.0 °F. The Unit Controller compares the current “*MX SUPPLY AIR TEMP CURRENT*” to the “*MX SUPPLY AIR TEMP SETPOINT*” plus or minus the “*COOLING CONTROL OFFSET*.” If the “*MX SUPPLY AIR TEMP CURRENT*” temperature is greater than the “*MX SUPPLY AIR TEMP SETPOINT*” plus the “*COOLING CONTROL OFFSET*” and all the compressors are not ON, the Unit Controller will initiate a call for compressor or additional compressor operation based on the “*NEXT STAGE TO ENABLE*.”

If the “*MX SUPPLY AIR TEMP CURRENT*” temperature is less than the “*MX SUPPLY AIR TEMP SETPOINT*” minus the “*COOLING CONTROL OFFSET*” and all the compressors are not OFF, the Unit Controller will turn a compressor OFF based on the “*NEXT STAGE TO DISABLE*.”

On a FLEXSYS unit with the current operating mode set to “*OCC COOLING W/BYP*,” when the Unit Controller enters an active cooling mode, the Unit Controller sets the “*COOLING CONTROL OFFSET*” to 2.0 °F. The Unit Controller compares the current “*FLEX EVAP TEMP CURRENT*” to the “*FLEX EVAP TEMP ACTIVE SP*” plus or minus the “*COOLING CONTROL OFFSET*.” If the “*FLEX EVAP TEMP CURRENT*” temperature is greater than the “*FLEX EVAP TEMP ACTIVE SP*” plus the “*COOLING CONTROL OFFSET*” and all the compressors are not ON, the Unit Controller will initiate a call for compressor or additional compressor operation based on the “*NEXT STAGE TO ENABLE*.”

If the “*FLEX EVAP TEMP CURRENT*” temperature is less than the “*FLEX EVAP TEMP ACTIVE SP*” minus the “*COOLING CONTROL OFFSET*” and all the compressors are not OFF, the Unit Controller will turn a compressor OFF based on the “*NEXT STAGE TO DISABLE*.”

When the Unit Controller turns a compressor ON or OFF, it records the SAT temperature just prior to the time the compressor is started or stopped. After the 3 1/2-minute Interstage Delay Timer has expired, the Unit Controller records the SAT temperature again. The Unit Controller then calculates the change in the SAT temperature  $SAT_{CH}$ . The Unit Controller uses the  $SAT_{(CH)}$  and FORMULA 1 to calculate a new “COOLING CONTROL OFFSET” if either of the following conditions are met:

- When a compressor is turned OFF and 3 1/2 minutes later the SAT temperature is greater than the “ACTIVE SAT SETPOINT” plus the current “COOLING CONTROL OFFSET.”
- When a compressor is turned ON and 3 1/2 minutes later the SAT temperature is less than the “ACTIVE SAT SETPOINT” minus the current “COOLING CONTROL OFFSET.”

$$“COOLING CONTROL OFFSET” = \frac{SAT \text{ (change)} + 1^\circ F}{2}$$

#### FORMULA 1

If a new “COOLING CONTROL OFFSET” is calculated, it is rounded up to the next half degree.

After a “COOLING CONTROL OFFSET” calculation is made, the Unit Controller initiates a 45-minute Cooling Control Offset Timer. If no compressor is turned ON or OFF before the Cooling Control Offset Timer has expired, the “COOLING CONTROL OFFSET” will be reset to 2.0 °F.

### COMPRESSOR OPERATION WITH ECONOMIZER

If the economizer is suitable, the Unit Controller will set the “COOLING CONTROL OFFSET” to 4.5 °F. As long as the economizer remains active, the Unit Controller will not recalculate the “COOLING CONTROL OFFSET” and it will remain at the 4.5 °F setting.

#### No Compressors On When Economizer Becomes Active

Compressors will be turned ON based on the “NEXT STAGE TO ENABLE,” when all the following are satisfied:

- The “ECONOMIZER CONTROL OUTPUT” to the economizer must be greater than 95% for 30 seconds. This value can be viewed under the ECONOMIZER key of the User Interface.
- The “SUPPLY AIR TEMP CURRENT” must be greater than or equal to the “SUPPLY AIR TEMP ACTIVE SP” plus the “COOLING CONTROL OFFSET” (4.5 °F).
- The Inter-Staged Delay Timer has expired.

Compressors will be turned OFF, based on the “NEXT STAGE TO DISABLE,” when all the following are satisfied:

- The “ECONOMIZER CONTROL OUTPUT” to the economizer is less than 5% for 30 seconds.
- The “SUPPLY AIR TEMP CURRENT” must be less than or equal to the “SUPPLY AIR TEMP ACTIVE SP” minus the “COOLING CONTROL OFFSET” (4.5 °F).
- The Inter-Staged Delay Timer has expired.

### Compressor On When Economizer Becomes Active

One compressor will be staged OFF, and then the sequenced outlined above will be followed.

### SUPPLY FAN OPERATION

#### Constant Volume Operation

The Supply Fan will be turned ON if the Supply Fan has been OFF for at least 60 seconds and one of the following conditions apply.

- The FAN (G) digital input is high; 24 volts is present at terminal “G” of the unit low voltage terminal block, or
- The “UNIT MODE” is other than OCCUPIED STANDBY OR UNOCCUPIED STANDBY, or
- The unit is in the MORNING WARMUP mode, or the unit modes of operation are CONTINUOUS VENT and OCCUPIED. “CONTINUOUS VENT” is ENABLED through the PROGRAM key, VENTILATION subsection of the User Interface. This energizes the Supply Fan on a CONSTANT VOLUME unit any time the operating mode is OCCUPIED.

The Supply Fan will be turned OFF if all of the following conditions are met:

- The Supply Fan has been ON for at least 60 seconds.
- The unit is in the OCCUPIED OR UNOCCUPIED STANDBY mode.
- The FAN (G) digital input is low; 24 volts is not present at “G” of the low voltage terminal block.
- The INACTIVE HEATING TIME is greater than or equal to 60 seconds.
- The INACTIVE COOLING TIME is greater than or equal to 60 seconds.
- The SUPPLY AIR TEMP is less than or equal to 85.0 °F.

- And either:
  - “CONTINUOUS VENT” is OFF, or
  - The CURRENT OPER MODE is set to UNOCCUPIED.

The Unit Controller monitors the operation of the Supply Fan by checking the status of a digital input from an air proving switch. After 45 seconds of operation, the Unit Controller looks for a high state (24 volt input) from the air proving switch circuit at terminal block TB7 pin 10 of the Unit Controller. It then examines the current state for 10 seconds. If the input does not go to a high state during this time frame the Unit Controller will set a SUPPLY FAN LOCKOUT and shut down all unit system operation.

### Variable Air Volume (VAV)

The Supply Fan will be turned ON if the Supply Fan has been OFF for at least 60 seconds and one of the following conditions apply:

- The FAN (G) digital input is high; 24 volts is present at terminal “G” of the unit low voltage terminal block, or
- The CURRENT OPER MODE is set to OCCUPIED, or
- The unit is in the MORNING WARMUP mode, or
- The UNIT MODE is UNOCCUPIED HEATING or UNOCCUPIED COOLING.

The Supply Fan will be turned OFF if all the following conditions are met:

- The Supply Fan has been ON for at least 60 seconds.
- The unit is in the UNOCCUPIED STANDBY mode.
- The FAN (G) digital input is low; 24 volts is not present at “G” of the unit low voltage terminal block.
- The INACTIVE HEATING TIME is greater than or equal to 60 seconds.
- The INACTIVE COOLING TIME is greater than or equal to 60 seconds.
- The SUPPLY AIR TEMP is less than or equal to 85.0 °F.

The Unit Controller monitors the operation of the Supply Fan by checking the status of a digital input from an air proven switch. After 45 seconds of operation, the control looks for a high state (24 volt input) from the air proving switch circuit at terminal block TB7 pin 10 of the Unit Controller. It then examines the current status for 10 seconds. If the input does not go to a high state during this time frame, the Unit Controller will set a SUPPLY FAN LOCKOUT and shut down all unit system operation.

The Unit Controller uses a proportional-integral control algorithm to maintain the “DUCT STATIC PRESSURE” by varying the speed of the supply fan. As the pressure goes up, the speed goes down.



*The bypass VFD is a standard Variable Frequency Drive packaged with an additional set of contactors. When bypass mode is activated, contactors route power around the VFD, connecting the indoor fan motor directly to the supply voltage. At this point, the motor will go to full RPM regardless of the duct pressure signal, because the VFD is out of the loop, and there is a potential for over pressuring the ducts.*



*The air balancer must set maximum duct static / CFM to stay within a static pressure that the ductwork of that installation can tolerate when the motor is at full RPM, considering that the VAV boxes, if they are part of the system, may not be full open.*

*If the duct system includes VAV boxes, they must be driven open in Bypass mode. Failure to do so could result in damage to the ductwork and the building structure.*

## VAV Supply Fan Speed Control

### Setpoint Determination

The following parameters must be set through the User Interface:

- “DUCT PRESS TRANSDUCER SPAN” – OPTIONS key / SUPPLY SYSTEM subsection.
- “DUCT STATIC RESET LOW SETP” – SETPOINTS key / SUPPLY SYSTEMS subsection.
- “DUCT STATIC RESET HIGH SETP” – SETPOINTS key / SUPPLY SYSTEMS subsection.

The “DUCT PRESS TRANSDUCER SPAN” can be set for 1.25" W.C., 2.50" WC, or 5.00" W.C. based on the duct static pressure transducer setting.

The Duct Static Limit can be varied through the “DUCT STATIC PRES RESET”, a 0.00- to 5.00-volt analog input to the Unit Controller. When the “DUCT STATIC PRES RESET” analog input is 0.00 volts, the “DUCT STATIC PRESS ACTIVE SP” is the “DUCT STATIC RESET HIGH SETP” value. When the “DUCT STATIC PRESSURE RESET” analog input is 5.00 volts, the “DUCT STATIC PRESS ACTIVE SETP” is the “DUCT STATIC RESET LOW SETP” value. When the “DUCT STATIC PRESSURE RESET” is between 0.00 and 5.00 volts, the “DUCT STATIC PRESS ACTIVE SETP” is linearly interpolated between the “DUCT STATIC RESET LOW SETP” and the “DUCT STATIC RESET HIGH SETP.”

The “DUCT STATIC HIGH SETP” can never be greater than the programmed “DUCT PRESS TRANSDUCER SPAN” (1.25" W.C., 2.50" W.C. or 5.00" W.C.).

The Unit Controller then varies the 0.00- to 10.00-volt analog output to the VFD to maintain the “DUCT STATIC PRESS ACTIVE SP.”

### Supply Fan Speed Determination

When the “Unit Type” is set to Single Zone VAV, the “SUPPLY FAN VFD SPEED” is determined by the difference between the “ZONE TEMP” and the appropriate zone setpoint. *Table 17 on page 69* shows the parameters that are used to determine the “SUPPLY FAN VFD SPEED.”

When the “Unit Mode” is Cooling High, a control loop shall modulate the “SUPPLY FAN VFD SPEED.” The Feedback Signal shall be the “ZONE TEMP.” The Proportional Band shall be between the COOLING SETPOINT + 1.5 °F to COOLING SETPOINT + 2.5 °F. The action of the control loop shall be direct acting (i.e., an increase in Zone Temperature will increase the Fan Speed.)

An adjustable “SINGLEZONE VAV MIN VFD SPEED” setpoint protects the unit from issues that may result from reduced supply fan airflow.

Range: 33.0% to 66.0%  
Default: 50.0%

**TABLE 17 - SUPPLY FAN VFD SPEED DETERMINATION**

$\Delta T_{OCC COOL}$	$\Delta T_{OCC HEAT}$	$\Delta T_{UNOCC COOL}$	$\Delta T_{UNOCC HEAT}$	OCCUPANCY MODE	UNIT MODE	SUPPLY FAN VFD SPEED
> 0.5 °F	---	---	---	Occupied	Occupied Cooling Low	SZVAV Min Speed
> 1.5 °F	---	---	---	Occupied	Occupied Cooling High	SZVAV Min Speed
> 2.5 °F	---	---	---	Occupied	Occupied Cooling High	100%
---	< -0.5 °F	---	---	Occupied	Occupied Heating Low	100%
---	< -1.5 °F	---	---	Occupied	Occupied Heating High	100%
---	---	---	---	Occupied	Occupied Standby (See Also Comfort Ventilation Operation)	SZVAV Min Speed
---	---	> 0.5 °F	---	Unoccupied	Unoccupied Cooling Low	SZVAV Min Speed
---	---	> 1.5 °F	---	Unoccupied	Unoccupied Cooling High	SZVAV Min Speed
---	---	> 2.5 °F	---	Unoccupied	Unoccupied Cooling High	100%
---	---	---	< -0.5 °F	Unoccupied	Unoccupied Heating Low	100%
---	---	---	< -1.5 °F	Unoccupied	Unoccupied Heating High	100%
---	---	---	---	Unoccupied	Unoccupied Standby	Off

**COMPRESSOR STAGING SEQUENCE**

Compressors are staged up or down to control the “SUPPLY AIR TEMP CURRENT” to the “SUPPLY AIR TEMP ACTIVE SP.”

The compressor staging sequence is determined by the unit size. This parameter is set through the User Interface as follows:

“UNIT SIZE” – OPTIONS key / UNIT DATA subsection.

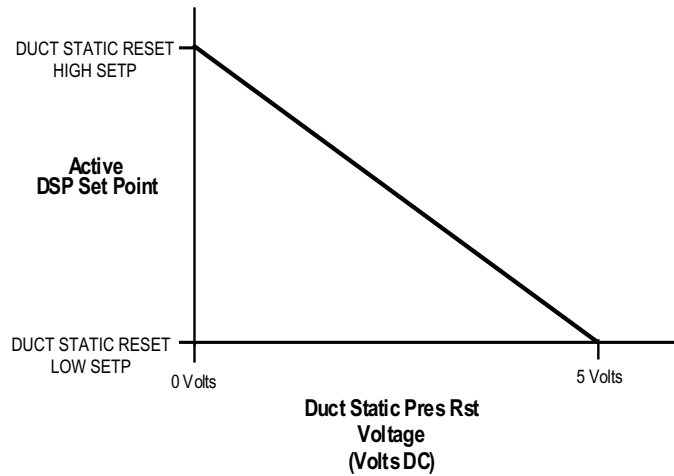

LD10309A

**FIGURE 30 - ACTIVE DSP SETPOINT VS. DUCT STATIC PRES RST VOLTAGE**

**TABLE 18 - 70-105 TON UNITS**

STAGING UP	NEXT STAGE TO ENABLE
Stage 0 to 1	If compressor 1A ready to run and compressor 1B ready to run are both true, the Unit Controller will set next stage to enable to either 1A or 1B, whichever compressor has the smallest number of starts.
Stage 1 to 2	If compressor 2A ready to run, compressor 2B ready to run, compressor 3A ready to run and compressor 3B ready to run are all true, the Unit Controller will set next stage to enable to either 2A, 2B, 3A, or 3B, whichever compressor has the smallest number of starts.
Stage 2 to 3	The Unit Controller will set next stage to enable to either the A or B compressor from the remaining system without a compressor on. For example, if a compressor is on from system 1 and system 3, then the next compressor on would be either 2A or 2B, whichever has the smallest number of starts.
Stage 3 to 4	The Unit Controller will set next stage to enable to the compressor remaining from the stage 0 to 1 transition.
Stage 4 to 5	The Unit Controller will set next stage to enable to the compressor remaining from the stage 1 to 2 transition.
Stage 5 to 6	The Unit Controller will set next stage to enable to the compressor remaining from the stage 2 to 3 transition.

STAGING DOWN	NEXT STAGE TO DISABLE
Stage 6 to 5	If compressor 3A ready to stop, compressor 3B ready to stop, compressor 2A ready to stop and compressor 2B ready to stop are all true, the Unit Controller will set next stage to disable to either 3A, 3B, 2A, or 2B, whichever compressor has the fewest number of starts.
Stage 5 to 4	The Unit Controller will set next stage to disable to either the A or B compressor from system 2 or 3 with two compressors on. For example, if system 3 has both compressors on, the Unit Controller will set the next stage to disable to either 3A or 3B, whichever has the fewest number of starts.
Stage 4 to 3	The Unit Controller will set next stage to disable to either 1A or 1B, whichever has the fewest number of starts.
Stage 3 to 2	The Unit Controller will set next stage to disable to the remaining compressor on the system the transitioned from 2 compressors to 1 compressor during the stage 6 to 5 operation.
Stage 2 to 1	The Unit Controller will set next stage to disable to the remaining compressor on the system the transitioned from 2 compressors to 1 compressor during the stage 5 to 4 operation.
Stage 1 to 0	The Unit Controller will set next stage to disable to the compressor remaining from system 1.

## CONDENSER FAN OPERATION

A call for the operation of compressor 1A or 1B will close an output at terminal TB4-9. This 24VAC output energizes the 7M contactor and turns on condenser fan 1A. This 24VAC output is also sent to pressure switch 11PS. If the discharge pressure rises above 360 plus or minus 10 PSIG, the 11PS switch closes and energizes the 8M contactor and energizes condenser fan 1B. If the discharge pressure decreases below 240 plus or minus 10 PSIG, the 11PS switch opens and de-energizes condenser fan 1B.

A call for the operation of compressor 2A or 2B will close an output at terminal TB6-2. This 24VAC output energizes the 9M contactor and turns on condenser fan 2A. This 24VAC output is also sent to pressure switch 12PS. If the discharge pressure rises above 360 plus or minus 10 PSIG, the 12PS switch closes and energizes the 10M contactor and energizes condenser fan 2B. If the discharge pressure decreases below 240 plus or minus 10 PSIG, the 12PS switch opens and de-energizes condenser fan 2B.

A call for the operation of compressor 3A or 3B will close an output at terminal TB6-4. This 24VAC output energizes the 11M contactor and turns on condenser fan 3A. This 24VAC output is also sent to pressure switch 13PS. If the discharge pressure rises above 360 plus or minus 10 PSIG, the 13PS switch closes and energizes the 12M contactor and energizes condenser fan 3B. If the discharge pressure decreases below 240 plus or minus 10 PSIG, the 13PS switch opens and de-energizes condenser fan 3B.

## LOW AMBIENT CONDENSER FAN OPERATION

The standard condenser fan arrangement will operate down to an ambient temperature of 50 °F. If mechanical cooling is required below 50 °F, the unit must be ordered with the pressure transducer option as well as a VFD (Variable Frequency Drive) for each refrigerant system that is required to operate below 50 °F. The speed of the primary condenser fan will be controlled to maintain a minimum discharge pressure of 220 PSIG.

## ECONOMIZER

Economizer is used in cooling mode only. As soon as the UNIT MODE switches to “OCCUPIED COOLING” or “UNOCCUPIED COOLING” and the conditions are within the programmed guidelines for economizer operation, the Unit Controller will attempt to use outdoor air to lower the supply air temperature to the “ACTIVE SAT SETPOINT.” The following parameters must be programmed into the Unit Controller through the User Interface to enable economizer operation:

- “ECONO METHOD TO USE” - OPTIONS key / ECONOMIZER subsection.
- The choices are “DRY BULB”, “SINGLE ENTHALPY”, “DUAL ENTHALPY”, “BEST AVAILABLE”.
- “OUTSIDE AIR ENTHALPY SETPOINT” - SETPOINTS key ECONOMIZER subsection.
- “ECONO INSTALLED” - OPTIONS key / ECONOMIZER subsection.
- The choices are “NONE,” “DRYBULB,” “SINGLE ENTHALPY,” “DUAL ENTHALPY”.

### Dry Bulb

When the “ECONO METHOD TO USE” is set to “DRY BULB,” the Unit Controller will reference the “OUTSIDE AIR TEMP” only to determine the “ECONO SYS STATUS.”

The “ECONO SYS STATUS” will be NORMAL - ACTIVE if all of the following conditions are met:

- The “OUTSIDE AIR TEMP” is less than or equal to the “SUPPLY AIR TEMP ACTIVE SP” plus 8.0 °F.
- The current “UNIT MODE” is OCC COOLING or UNOC COOLING.

Once the “ECONO SYS STATUS” is NORMAL - ACTIVE, the “ECONO SYS STATUS” is set to NORMAL - INACTIVE if any of the following are met:

- The “OUTSIDE AIR TEMP” is greater than or equal to the “SUPPLY AIR TEMP ACTIVE SP” plus 10.0 °F.
- The current “UNIT MODE” is not OCC COOLING or UNOCC COOLING.

### Single Enthalpy

When the “*ECONO METHOD TO USE*” is set to “*SINGLE ENTHALPY*,” the controller will reference the “*OUTSIDE AIR TEMP*” and “*OUTSIDE AIR ENTHALPY*” (derived from the “*OUTSIDE AIR TEMP*” and “*OUTSIDE AIR HUMIDITY*”) to determine the “*ECONO SYS STATUS*.”

The “*ECONO SYS STATUS*” will be NORMAL - ACTIVE if all of the following conditions are met:

- The “*OUTSIDE AIR TEMP*” is less than or equal to the “*SUPPLY AIR TEMP ACTIVE SP*” plus 8.0 °F.
- The “*OUTSIDE AIR ENTHALPY*” is less than or equal to the “*OUTSIDE AIR ENTHALPY SETPOINT*.”
- The current “*UNIT MODE*” is OCCUPIED COOLING or UNOCCUPIED COOLING.

Once the “*ECONO SYS STATUS*” is NORMAL - ACTIVE, the “*ECONO SYS STATUS*” is set to NORMAL - INACTIVE if any of the following are met:

- The “*OUTSIDE AIR TEMP*” is greater than or equal to the “*SUPPLY AIR TEMP ACTIVE SP*” plus 10.0 °F.
- The “*OUTSIDE AIR ENTHALPY*” is greater than or equal to the “*OUTSIDE AIR ENTHALPY SETPOINT*” plus 1 BTU/LB.
- The current “*UNIT MODE*” is not OCC COOLING or UNOCCUPIED COOLING.

### Dual Enthalpy

When the “*ECONO METHOD TO USE*” is set to “*DUAL ENTHALPY*,” the Unit Controller will reference the “*OUTSIDE AIR TEMP*,” “*OUTSIDE AIR ENTHALPY*” (derived from “*OUTSIDE AIR TEMP*” and “*OUTSIDE AIR HUMIDITY*”), and “*RETURN AIR ENTHALPY*” (derived from “*RETURN AIR TEMP*” and “*RETURN AIR HUMIDITY*”) to determine the “*ECONO SYS STATUS*.”

The “*ECONO SYS STATUS*” will be NORMAL - ACTIVE if all of the following conditions are met:

- The “*OUTSIDE AIR TEMP*” is less than or equal to the “*SUPPLY AIR TEMP ACTIVE SP*” plus 8.0 °F.
- The “*OUTSIDE AIR ENTHALPY*” is less than or equal to the “*RETURN AIR ENTHALPY*” – 1 BTU/LB.

- The current “*UNIT MODE*” is OCCUPIED COOLING or UNOCCUPIED COOLING.

Once the “*ECONO SYS STATUS*” is NORMAL - ACTIVE, the “*ECONO SYS STATUS*” is set to NORMAL INACTIVE if any of the following are met:

- The “*OUTSIDE AIR TEMP*” is greater than or equal to the “*SUPPLY AIR TEMP ACTIVE SP*” plus 10.0 °F.
- The “*OUTSIDE AIR ENTHALPY*” is greater than or equal to the “*RETURN AIR ENTHALPY*.”
- The current “*UNIT MODE*” is not OCCUPIED COOLING or UNOCCUPIED COOLING.

### Best Method

When the “*ECONO METHOD TO USE*” is set to “*BEST AVAILABLE*,” the Unit Controller will determine the “*ECONO METHOD TO USE*” based on the sensor that is installed and reliable. The “*DRY BULB*” method will be used if only the “*OAT SENSOR RELIABLE*” is true. The Single Enthalpy method will be used if both the “*OAT SENSOR RELIABLE*” and the “*OA HUMIDITY SENSOR RELIABLE*” are true. The Dual Enthalpy method shall be used if the “*OAT SENSOR RELIABLE*,” “*RET SENSOR RELIABLE*,” “*OA HUMIDITY SENSOR RELIABLE*,” and the “*RA HUMIDITY SENSOR RELIABLE*” are all true.

With this setting, all of the above logic for Dry Bulb, Single enthalpy, and Dual Enthalpy apply.

### Nonflexsys Economizer

Once the “*ECONO SYS STATUS*” is “*NORMAL - ACTIVE*,” the Unit Controller will use the “*ECONOMIZER CONTROL OUTPUT*” to control the return and outdoor damper to maintain the “*SUPPLY AIR TEMP ACTIVE SP*.”

### FlexSys Economizer

The FlexSys economizer suitability is the same as the above except for the “*OUTSIDE AIR TEMP*” requirement. On FlexSys units, the “*OUTSIDE AIR TEMP*” must be at least 2.0 °F below the “*MX SUPPLY AIR TEMP SETPOINT*” in order for the economizer to become NORMAL - ACTIVE.

When the economizer is NORMAL - ACTIVE, it will go NORMAL INACTIVE if the “*OUTSIDE AIR TEMP*” is equal to or above the “*MX SUPPLY AIR TEMP SETPOINT*.”



Also when economizer is active, the setpoint for the “*ECONOMIZER CONTROL OUTPUT*” will be the “*MX SUPPLY AIR TEMP SETPOINT*” setting, and the Feedback will be the “*MX SUPPLY AIR TEMP CURRENT*.”

## COMPRESSOR OPERATION

### Fast Compressor Start

On the Series 100, 70–105 ton, Rev F units, there is the ability to User Enable a Fast Compressor Start sequence. The Fast Compressor Start sequence allows the unit to quickly stage on numerous compressors with only a 10 second delay between compressors starting, as opposed to the standard 3.5-minute inter-stage time delay between compressors starting. This function will only be utilized when transitioning from the Occupied Standby mode to the Occupied Cooling mode.

The S100 70-105 ton Rev F units have 6 stages of cooling.

### Sequence of Operation

- Fast Compressor Start must be User Enabled
- Unit Controller transitions to Occupied Cooling from Occupied Standby
- The unit controller will perform a calculation looking at the current RAT, current SAT and the active SAT SP. The results of this calculation will determine how many stages of mechanical cooling are needed to quickly achieve and maintain the active SAT SP
- The unit controller will start the appropriate number of compressors with a 10 second delay between starts as per *Table 18 on page 70*.
- Once the unit controller has the appropriate number of compressors running, the compressor staging sequence will revert to the standard 3.5-min delay between starting another stage of mechanical cooling.

### Compressor Data

In order to assist the Service Technician and to assure equal wear on all the compressors in the unit, the Unit Controller records the following data pertinent to compressor operation for each compressor:

**COMPRESSOR STARTS** – Each time one of the compressors state transitions from OFF to ON, the “*COMPRESSOR # STARTS*” will be incremented by one, where # will vary to match the compressor number the

data is being recorded for: 1A, 1B, 2A, etc. This data can be view under the OPERATING HOURS / START COUNTER key of the User Interface.

**COMPRESSOR OPERATING HOURS** – While the compressor is in the ON state, the “*COMPRESSOR # OPER HRS*” will be incremented once for every hour of operation. This value will be accumulated over the lifetime of the compressor. # will vary to match the compressor number the data is being recorded for: 1A, 1B, 2A, etc. This data can be view under the OPERATING HOURS / START COUNTER key of the User Interface.

**COMPRESSOR RUN TIME** – While the compressor is in the ON state, the “*COMPRESSOR # RUN TIME*” shall be incremented once per minute. The value will only be accumulated during the current run state and will be reset to zero when the COMPRESSOR RUN STATE switches from ON to OFF. The # symbol will vary to match the compressor number the data is being recorded for. This data can be viewed under the COMPRESSOR SYSTEMS key of the User Interface.

### Compressor Ready To Run

With the “*COMPRESSOR # STATE*” OFF, the Unit Controller determines if a compressor is ready to run by monitoring the following derived data:

- “*HIGH DP UNLOAD*”
- “*LOW AMB INHIBIT*”
- “*LOW SUCTION TEMP UNL*”
- “*COMPR # SAFETY TRIP*”
- “*COMPR # SAFETY FAULT*”
- “*COMPR # SAFETY LOCK OUT*”

If all of the above parameters are FALSE (not active) and the minimum OFF time has been satisfied, the compressor will be placed in the ready to run state.

# number will vary to match the compressor number the data is being recorded for: 1A, 1B, 2A, etc.

### Compressor Ready To Stop

The Unit Controller will set the “*COMPRESSOR # READY TO STOP*” to true when the MINIMUM ON TIMER (3 1/2 minutes) has been satisfied.

The # symbol will vary to match the compressor number the data is being recorded for: 1A, 1B, 2A, etc.

## Compressor Safety Circuit

Each compressor system is equipped with external circuitry monitoring hardware. This hardware is intended to protect the compressors in case the operating characteristics of the refrigeration system fall outside the safe operating envelope for the compressors.

- YPAL 070 - Compressors 1A, 1B, 2A, 2B, 3A, and 3B
- YPAL 075 - Compressors 2A, 2B, 3A, and 3B
- YPAL 080 - compressors 3A and 3B

The following safeties comprise the safety circuit:

- Compressor Overload (Manual Motor Starter)
- High Pressure Cutout
- Internal Line Break In The Compressor.

Each of the compressors is protected from excessive current or temperatures by internal line break protection imbedded in the windings of the compressor. The Unit Controller will not be able to identify whether the internal line break switch is open, and no fault will be generated or reported by the Unit Controller.

If the internal line break is open, it will appear as a compressor failure. To troubleshoot, verify the contactor for the compressor that is not running is closed and line voltage is present on the load and line side of all three legs. If so, remove power from the unit and remove the cover from the compressor control box. Check for an open winding. If all three windings are open, carefully check the compressor shell. If the shell is hot, no determination can be made until the shell has cooled. If the shell is cool and the winding is open, the compressor is defective. If the windings close as the compressor cools; the internal line break switch was open. Some possible reasons for the switch to open are:

- High discharge super heat (low charge)
- Start of a bearing failure (partially locked rotor)
- High voltage

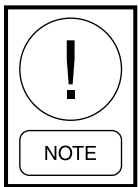

***The unit also has a low-pressure cutout and monitors the suction line temperature to protect against liquid flood back to the compressor. These items will be discussed later in this section of the manual.***

The above safety circuit supplies a digital 24V signal to the Unit Controller. The input for compressor Sys-

tem 1 is terminal block TB7 pin 1, System 2 TB7 pin 2, and System 3 TB7 pin 4. If one of the safeties opens, the signal is lost. When this occurs, the Unit Controller turns off both compressors of the compressor system having the fault. The Unit Controller then records the time it takes for the safety circuit to reestablish the 24V circuit to the Unit Controller. The time to reset is displayed in the history buffer and is identified as “*COMP STATUS (1, 2, OR 3) CLEAR TIME.*” The length of time it takes to reset is an indication of which of the safeties opened. For example, the Compressor Solid State Motor Protector takes 30 minutes to reset. The High Pressure Cutout usually resets in less than a minute, and the Manual Motor Starter must be reset by hand. If the reset time is greater than 60 minutes, as would be the case with the Manual Motor Starter, after 60 minutes the history buffer will replace “*COMP STATUS (1, 2, OR 3) CLEAR TIME*” with “*COMPRESSOR SYSTEM (1, 2, OR 3) TIME OUT.*”

- YPAL 075 - Compressor 1A and 1B
- YPAL 080 - Compressor 1A, 1B, 2A, and 2B
- YPAL 090, 105 - Compressors 1A, 1B, 2A, 2B, 3A and 3B
- The following safeties comprise the safety circuit:
  - Compressor Solid State Motor Protector
  - Compressor Overload (Manual Motor Starter)
  - High Pressure Cut Out

This safety circuit supplies a digital 24V signal to the Unit Controller. The input for compressor System 1 is terminal block TB7 pin 1, System 2 TB7 pin 2 and System 3 TB7 pin 4. If one of the safeties opens, the signal is lost. When this occurs, the Unit Controller shuts off both compressors of the compressor system having the fault. The Unit Controller then records the time it takes for the safety circuit to reestablish the 24V circuit to the Unit Controller. The time to reset is displayed in the history buffer and is identified as “*COMP STATUS (1, 2, OR 3) CLEAR TIME.*” The length of time it takes to reset is an indication of which of the safeties opened. For example, the Compressor Solid State Motor Protector takes 30 minutes to reset. The High Pressure Cutout usually resets in less than a minute and the Manual Motor Starter must be reset by hand. If the reset time is greater than 60 minutes (as would be the case with the Manual Motor Starter), the history buffer will (after 60 minutes) replace “*COMP STATUS (1, 2, OR 3) CLEAR TIME*” with “*COMP SYSTEM (1, 2, OR 3) TIME OUT.*”

The safety circuit input is ignored when both compressors of the system are OFF. If either or both of the compressors are active and the 24-volt safety circuit input is lost to the Unit Controller for two seconds, the Unit Controller turns off the active compressors for that system. The compressor system will be made active again when the safety circuit is reestablished. However, the event will be stored in the History buffer. During the time the safety circuit is open the User Interface will display the following messages:

- STATUS screen - *“COMPR SYS # STATUS - SAFETY TRIP”*
- COMPRESSOR SYSTEM # screen - *“SAFETY TRIP”*
- The HISTORY buffer will store and display the following - *“COMP # SAFETY TRIP (1 OR 2)”* depending if this is the first or second trip

If the safety circuit opens three times in a 120-minute window, the Unit Controller will lock out the compressor system having the fault and prevent further operation of that compressor system until the system is manually reset. The User Interface will display the following messages:

- STATUS screen - *“COMPR SYS # STATUS - SAFETY LOCKOUT”*.
- COMPRESSOR SYSTEM # screen - *“SAFETY-LOCKOUT”*.
- The HISTORY buffer will store and display the following - *“COMP # SAFETY LOCKOUT”*.

### Low Pressure Cutout

The operation of the low pressure cutout is the same as the other safety controls described in the previous section except the Unit Controller ignores the input from the Low Pressure cutout circuit during the first 45 seconds following the start up of the compressor system. This allows the system pressure to rise during startup particularly if the unit has the pump down option installed. The input to the Unit Controller is a 24-volt digital input at terminal block TB7 pin 5 for System 1, TB7 pin 7 for System 2, and TB7 pin 8 for System 3.

The Low Pressure Safety circuit input is ignored when both compressors of the system are OFF. If either or both of the compressors are active and the 24-volt signal is lost to the Unit Controller for two seconds, the Unit Controller turns off the active compressors for that system. The compressor system will be made

active again when the safety circuit is reestablished. However, the event will be stored in the History buffer. During the time the safety circuit is open the User Interface will display the following messages:

- STATUS screen - *“COMPR SYS # STATUS - SAFETY TRIP”*
- COMPRESSOR SYSTEM # screen - *“SAFETY TRIP”*
- The HISTORY buffer will store and display the following - *“COMP # LPCO SAFETY TRTP (1 OR 2)”* depending if this is the first or second trip

If the Low Pressure safety circuit opens three times in a 120-minute window, the Unit Controller will lock out the compressor system having the fault and prevent further operation of that compressor system until the system is manually reset. The User Interface will display the following messages:

- STATUS screen - *“COMPR SYS # STATUS - SAFETY LOCKOUT”*
- COMPRESSOR SYSTEM # screen - *“SAFETY-LOCKOUT”*
- The HISTORY buffer will store and display the following - *“COMP # LPCO SAFETY LOCK-OUT”*

### Suction Temperature Monitoring

If either or both compressors of a system are active, the Unit Controller will monitor the analog input from the suction line temperature sensors for the system. If the suction line temperature drops below the *“SUCTION LOW LIMIT”* setting, (37.0 °F) for 10 continuous seconds, the Unit Controller will post the following messages, under the STATUS key *“COMP SYS (1,2, OR 3) STATUS – LOW SUCT TEMP UN,”* COMPRESSOR SYSTEM (1,2, or 3) key *“SYSTEM STATUS LOW SUCT TEMP UNL;”* and under the HISTORY key *“LOW SUCTION TEMP (1,2, OR 3) TRIP.”* The analog suction temperature inputs enter the Unit Controller through J3 pin 1 for System 1, J3 pin 4 for System 2 and J3 pin 7 for System 3.

If both compressors were operative at the time of the fault, the Unit Controller will turn off the compressor with the longest Compressor Run Time. The Unit Controller will then wait one minute and then check the analog input from the suction line temperature sensor. If the suction line temperature drops below the setting, (34.0 °F for R-22 and 37.0 °F for R-407C and R-410A)

for 10 continuous seconds, the Unit Controller will turn off the other compressor of the system with the fault and display under the STATUS key “*COMP SYS (1,2, OR 3) STATUS – SAFETY TRIP,*” COMPRESSOR SYSTEM (1,2, or 3) key “*SYSTEM STATUS SAFETY TRIP;*” and under the HISTORY key LOW SUCTION TEMP (1,2, or 3) TRIP.

The fault will be cleared for each compressor when the suction line temperature is greater than the “*SUCTION LOW LIMIT*” setting plus 10.0 °F for 10 minutes.

## SUPPLY AIR TEMPERING

In some installations the ventilation requirements combined with low outdoor temperature can result in the Supply Air Temperature dropping below the “*SUPPLY AIR TEMP ACTIVE SP,*” resulting in an over cooling of the space. Supply Air Tempering uses the units heating source to raise the Supply Air Temperature to an acceptable level.

In order for Supply Air Tempering to be active, the following items must be programmed into the Unit Controller. Under the PROGRAM key, HEATING subsection, “*HEATING SYSTEM*” must be set to USER ENABLE. Under the PROGRAM key, COOLING subsection, “*SUP AIR TEMPERING*” must be set to USER ENABLE.

The Supply Air Tempering logic will vary depending on the type of heat installed in the unit. A description of each of the operating logics follows.

### Modulating Gas Heat, Hot Water and Steam

In order for the Supply Air Tempering to be enabled, the following conditions must be met:

- Operating Conditions
  - For CV and VAV units, the “*SUPPLY AIR TEMP*” must be less than or equal to the “*SUPPLY AIR TEMP ACTIVE SP*” minus 2.5 °F for 5 minutes.
  - For FlexSys without Bypass, the “*MX SUPPLY AIR TEMP*” must be less than or equal to the “*MX SUPPLY AIR TEMP SETPOINT*” MINUS 2.5 °F for 5 minutes.
  - For FlexSys with Bypass, the “*RETURN AIR BYPASS CURRENT*” must be more than or equal to the “*MAXIMUM BYPASS*” minus 5%.

- Economizer Output must be less than or equal to 5%.
- Compressor operation must have been OFF for 10 minutes.

On modulating hot water and steam, the following criteria must be met to terminate the Supply Air Tempering:

- Operating Conditions
  - For CV and VAV units the “*SUPPLY AIR TEMP*” must be more than or equal to the “*SUPPLY AIR TEMP ACTIVE SP*” for 5 minutes.
  - For FlexSys with or without Bypass the “*SUPPLY AIR TEMP*” must be more than or equal to the “*MX SUPPLY AIR TEMP*” for 5 minutes.
- The “*HEATING VALVE*” must be less than or equal to 2%.

On modulating gas heat, the following criteria must be met to terminate the Supply Air Tempering:

- Operating Conditions
  - For CV and VAV units the “*SUPPLY AIR TEMP*” must be more than or equal to the “*SUPPLY AIR TEMP ACTIVE SP*” plus 4.0 °F for 5 minutes.
  - For FlexSys with or without Bypass the “*MX AIR TEMP*” must be more than or equal to the “*MX SUPPLY AIR TEMP SETPOINT*” plus 4.0 °F for 5 minutes.
- The “*HEATING VALVE*” must be at minimum, inducer fan on low, and no other furnace stages ON.

### Staged Gas or Electric Heat

In order for the Supply Air Tempering to be enabled, the following conditions must be met:

- Operating Conditions
  - For CV and VAV units the “*SUPPLY AIR TEMP*” must be less than or equal to the “*SUPPLY AIR TEMP ACTIVE SP*” minus 2.5 °F for 5 minutes.
  - For FlexSys without Bypass the “*MX AIR TEMP*” must be less than or equal to the “*MX SUPPLY AIR TEMP SETPOINT*” MINUS 2.5 °F for 5 minutes.

- For FlexSys with Bypass the “*RETURN AIR BYPASS CURRENT*” must be more than or equal to the “*MAXIMUM BYPASS*” minus 5%.
- Economizer Output must be less than or equal to 5%.
- Compressor operation must have been OFF for 10 minutes.
- The “*HEAT ENTERING TEMP*” must be less than or equal to the “*SUPPLY AIR TEMP ACTIVE SP*” minus 5.0 °F for 5 minutes.

The stage heat will stage up and down based on the following criteria:

- The heat section will stage up if the “*SUPPLY AIR TEMP*” is less than or equal to the “*SUPPLY AIR TEMP ACTIVE SP*” minus 5.0 °F.
- The heat section will stage down if the “*SUPPLY AIR TEMP*” is more than or equal to the “*SUPPLY AIR TEMP ACTIVE SP*” plus 2 x the “*HEATING CONTROL OFFSET*” minus 5.0 °F.
- If 2 x the “*HEATING CONTROL OFFSET*”
- 5.0 °F is less than 5.0 °F the value will be set to 5.0 °F.

The following criteria must be met to terminate the Supply Air Tempering:

- The “*HEAT ENTERING TEMP*” must be more than or equal to the “*SUPPLY AIR TEMP ACTIVE SP*” for 5 minutes.

## COMFORT VENTILATION

In order for this mode of operation to function the following parameters must be programmed into the Unit Controller through the User Interface:

- “*UNIT TYPE*” must be set to “*CONSTANT VOLUME*” using the OPTIONS key, UNIT DATA subsection of the User Interface.
- “*COMFORT VENTILATION*” must be USER ENABLED using the PROGRAM key, VENTILATION subsection of the User Interface.
- “*OCC ZONE COOLING SETPOINT*” must be set using the SETPOINTS key, COOLING subsection of the User Interface.
- “*OCC ZONE HEATING SETPOINT*” must be set using the SETPOINTS key, HEATING subsection of the User Interface.

When “*COMFORT VENTILATION*” is selected, the Unit Controller monitors the “*SUPPLY AIR TEMP*” and uses it to energize mechanical cooling or heating even though the thermostat or zone sensor satisfies the normal heating or cooling demand. This prevents the space temperature from getting out of bounds before mechanical heating or cooling is energized. This is usually used when there is a large demand for outdoor air for ventilation.

If the “*SUPPLY AIR TEMP*” is equal to or greater than the “*OCC ZONE COOLING SETPOINT*” plus 5.0 °F the Unit Controller will enter the COMFORT VENT COOLING mode and initiate compressor operation.

If the “*SUPPLY AIR TEMP*” is equal to or less than the “*OCC ZONE HEATING SETPOINT*” minus 5.0 °F, the Unit Controller will enter the COMFORT VENT HEATING mode and initiate heating operation.

The Unit Controller will terminate COMFORT VENT mode if:

- The “*SUPPLY AIR TEMP*” is less than the “*OCC ZONE COOLING SETPOINT*” minus 5.0 °F for 5 minutes.
- The “*SUPPLY AIR TEMP*” is greater than the “*OCC ZONE HEATING SETPOINT*” plus 5.0 °F for 5 minutes.
- The unit switches into the OCCUPIED HEATING OR OCCUPIED COOLING mode as a result of a space sensor demand for cooling or heating.

## SYSTEM PUMP DOWN CONTROL



***It is strongly recommended that the pump down option be kept at USER DISABLED. Failure to do so could result in the following nuisance faults: AUTO RESET - LPCO 1, AUTO RESET - LPCO 2, LOCKOUT LPCO.***

In order for the pump down cycle to work the unit must have a liquid line solenoid valve installed in the main liquid line of each compressor system at the factory. In addition, “*PUMP DOWN*” must be set to USER ENABLED through the User Interface. To do this, enter the PROGRAM key, COMPRESSOR SYSTEM subsection and scroll to “*PUMP DOWN*” and enter USER ENABLED.

Whenever either compressor of a compressor system is turned ON, the Unit Controller will energize the digital output to “*PUMP DOWN LLSV (1, 2 OR 3)*.” This digital output can be found at terminal 2 of terminal block TB5 for system 1, terminal 4 of terminal block TB5 for system 2, and terminal 6 of terminal block TB5 for system 3. Terminal block TB5 is located on the Unit Controller. This is done regardless of whether pump down is enabled or not.

When the last compressor of a compressor system is shut off and pump down is enabled, the Unit Controller will de-energized the “*PUMPDOWN LLSV*” for that system, start a 30-second Pump Down Monitor Timer, and set the internal Pump Down Active flag to ON. The compressor will continue to operate until the Pump Down Active flag is turned OFF. The Pump down Active flag will be turned OFF if either of the following conditions is met:

- The COMPRESSOR LPCO (low pressure cutout) for that system opens.
- The 30-second Pump Down Monitor timer has timed out.

If the liquid line solenoid valve is installed but “*PUMP DOWN*” is set to USER DISABLED, the internal Pump Down Active flag will remain OFF when the last compressor of the system is shut off and the compressor will shut off and the solenoid valve will close as soon as the call for compressor operation is terminated.

If the compressor is shut down due to a Refrigerant System Safety fault the compressor will shut down immediately and the system will not pump down.

### HIGH DISCHARGE PRESSURE UNLOADING

By unloading compressors before the discharge pressure reaches the high pressure cutout setting we can help prevent systems lock outs because of high pressure cut out, and continue to provide some cooling with high outside air temperatures, overcharged systems, or dirty condenser coils.

The High Discharge Pressure Unloading setpoint “*SYSTEM UNLOADING PRESSURE*” is programmed through the User Interface SETPOINT, subsection COMPRESSOR SYSTEMS key.

In order for this feature to be active the unit must have a discharge pressure transducer installed on each system where High Discharge Pressure Unloading is intended to function. The operation of the High Discharge Pressuring Unloading feature is as follows:

- Both compressors must be active in the system before High Discharge Pressure Unloading can occur.
- The system discharge pressure must be more than or equal to the “*SYSTEM UNLOADING PRESSURE SETPOINT*” for 10 seconds.
- The Unit Controller will then turn off one of the compressor from the system with the fewest number of starts.
- At the point the compressor is turned OFF the Unit Controller will record the Outdoor Temperature.
- The Unit Controller will then compare the current Outdoor Air Temperature to the Outdoor Temperature at the time the compressor shut down.
- If the Current Outdoor Temperature is less than or equal to the Outdoor Temperature at the time of shut down minus 5.0 °F, the Unit Controller will remove the High Pressure Unloading fault and allow the compressor to restart.

During the time the High Discharge Pressure is active, the STATUS display of the User Interface will show “*HIGH DP UNLOAD*” under the COMP SYS (1, 2 OR 3) STATUS subsection. The SYSTEM STATUS subsection of the COMPRESSOR SYSTEM (1, 2, or 3) key will also show “*HIGH DP UNLOAD.*”

### LOW AMBIENT LOCK OUT

The Unit Controller will allow compressor operation down to 0.0 °F for each refrigerant system that has a discharge pressure transducer and a condenser fan VFD installed. If the refrigerant system does not have both a discharge pressure transducer and a condenser fan VFD, the minimum outdoor temperature is 50.0 °F. However the decision can be made to prevent compressor operation above this minimum allowable setting; 0.0 °F when discharge pressure transducers and condenser fan VFD’s are installed or 50.0 °F when discharge pressure transducers and condenser fan VFD’s are not installed.

For low ambient operation, the Lock Out Temperature (“*MECH CLG LOCKOUT TEMP*”) value is programmed under the SETPOINT subsection, COOLING key of the User Interface. THE “*MECH COOL LOCKOUT TEMP*” can never be set lower than 0.0 °F. The addition of a condenser fan VFD is programmed through “*LOW AMBIENT PKG,*” which is under the OPTION subsection, COMP SYSTEM 01, 02, or 03 key of the User Interface. The addition of discharge pressure transducers is programmed through “*PRESS TRANS PKG,*” which is under the OP-

TION subsection, COMP SYSTEM 01, 02, or 03 key of the User Interface. Both “PRESS TRANS PKG” and a “LOW AMBIENT PKG” can be programmed for NONE; SYS 1; SYS 1, 2; or SYS 1, 2, 3.

The Unit Controller will derive an “ACTIVE MECH COOL LOCKOUT TEMP” value based on the following criteria:

- If the Discharge Pressure Transducer is unreliable, the “ACTIVE MECH COOL LOCKOUT TEMP” is the higher of the “MECH CLG LOCKOUT TEMP” or 50.0 °F.
- If the Outdoor Temperature sensor is unreliable all compressor operation is prohibited.
- If the Discharge Pressure Transducer and the Outdoor Temperature sensor are reliable, the “ACTIVE MECH COOL LOCKOUT TEMP” will be the higher of the “MECH CLG LOCKOUT TEMP” or 0.0 °F.
- If a “PRESSURE TRANS PKG” or “LOW AMBIENT PKG” is not installed and the Outdoor Temperature sensor is reliable, the “ACTIVE MECH COOL LOCKOUT TEMP” will be the higher of the “MECH CLG LOCKOUT TEMP” or 50.0 °F.

If the Outside Air Temperature is less than or equal to the “ACTIVE MECH COOL LOCKOUT TEMP” for 10 seconds, the Unit Controller will turn off all the compressors for the system.

If the Outside Air Temperature is more than or equal to the “ACTIVE MECH COOL LOCKOUT TEMP” plus 2.0 °F for 10 seconds and the compressor minimum OFF time has been satisfied, the compressors will be allow to restart.

During the time the Low Ambient Lock Out is active, the STATUS display of the User Interface will show “LOW AMB INHIBIT” under the COMP SYS (1, 2 OR 3) STATUS subsection. The SYSTEM STATUS subsection of the COMPRESSOR SYSTEM (1, 2, or 3) key will also show “LOW AMB INHIBIT.”

### LOW AMBIENT FAN CONTROL OPTION

#### General

If the refrigerant system is configured for low ambient operation, “LOW AMBIENT PKG” is turned ON for the refrigerant system. In addition, the unit will have a VFD installed to control the speed of the first condenser fan (1A, 2A, or 3A). The VFD is located in an

enclosure on the right hand side of the condenser section, attached beneath the condenser coil support for the refrigerant system it is controlling.

### Operation and Pressure Control Range

The VFD controls the speed of the fan based on a discharge pressure setpoint and a differential range. When discharge pressure reaches approximately 270 PSIG, the VFD will start the fan if the Unit Controller is calling for compressor / condenser fan operation. The binary outputs from the Unit Controller are as shown in *Table 19 on page 79*.

**TABLE 19 - BINARY OUTPUTS**

CONDENSER FAN	TERMINAL BLOCK	TERMINAL #	WIRE #	CONTACTOR
1A	TB-4	9	437	7M
2A	TB-6	2	439	9M
3A	TB-6	5	441	11M

As soon as the respective contactor is energized, the VFD will be activated and will begin to control. As the pressure rises over the next 80 PSIG (270 – 350 PSIG), the fan speed will increase to full speed at approximately 350 PSIG.

The VFD control input signal originates from the discharge pressure transducer for the compressor system it is controlling. The transducer signal feeds both the Unit Controller and the VFD. The VFD controls the fan speed based on discharge pressure.

### Configuration (Jumpers and Potentiometers)

The inverter is configured at the factory. The jumpers must be in the positions shown in *Table 20 on page 79*.

**TABLE 20 - VFD JUMPERS**

JUMPER	60 HZ	50 HZ
J2	REMOVE	REMOVE
J3	REMOVE	REMOVE
J4	REMOVE	REMOVE
J5	MIDDLE 2 PINS	MIDDLE 2 PINS
J6	MIDDLE 2 PINS	MIDDLE 2 PINS
J7	IN	IN
J8	IN	IN
J9	IN	REMOVE

Potentiometer settings are also preset at the factory. The potentiometers should be in the positions shown in *Table 21 on page 80*. The potentiometers do not have numerical settings and are set according to the

positions indicated. DO NOT change potentiometer settings unless they do not match the positioning of the potentiometers shown in *Figure 31 on page 80*. Modifying these settings may cause damage to the unit, control problems, and/or poor operating efficiency.

**TABLE 21 - POTENTIOMETER SETTINGS**

P1	P2
350 PSIG	80 PSIG
6 O'CLOCK	6 O'CLOCK

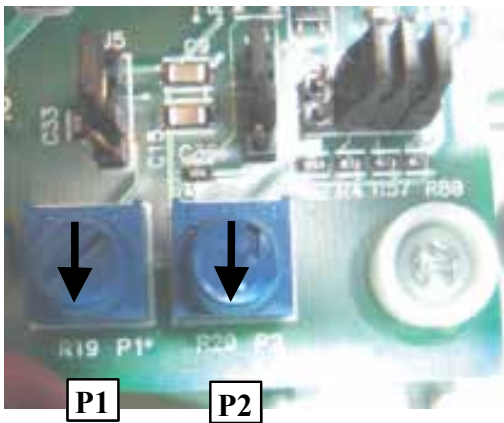

LD11300B

**FIGURE 31 - CONDENSER FAN VFD  
POTENTIOMETER SETTINGS**

### FLEXSYS BYPASS DAMPER OPERATION

On some FlexSys installations, a bypass damper may be installed to temper the air going to the underfloor or overhead delivery system. The bypass damper mixes return air with the air leaving the evaporator coil in order to meet the programmed “MX SUPPLY AIR TEMP SETPOINT” going to the conditioned space.

To determine the “RETURN AIR BYPASS ACTIVE SP,” the controller uses the “MX SUPPLY AIR TEMP,” “FLEX EVAP TEMP ACTIVE SETPOINT,” and the “RETURN AIR TEMP” to calculate the “RETURN AIR BYPASS ACTIVE SP” using Formula 1.

If the “RETURN AIR BYPASS ACTIVE SP” is calculated to be greater than the “MAXIMUM BYPASS,” the “RETURN AIR BYPASS ACTIVE SP” shall be equal to the “MAXIMUM BYPASS.”

The following logic is used in the control of the Bypass Damper:

- If the “FLEX EVAP TEMP” is more than the “MX SUPPLY AIR TEMP” setpoint for 10 minutes, the control will set the bypass damper to 0%.
- If the “FLEX EVAP TEMP” is less than the “MX SUPPLY AIR TEMP” setpoint and a compressor has been started or stopped in the last 7 minutes, the bypass damper is held at its current position.
- If the “FLEX EVAP TEMP” is less than the “MX SUPPLY AIR TEMP” setpoint and the difference between the “FLEX EVAP TEMP” and the “FLEX EVAP TEMP ACTIVE SP” is less than or equal to the “COOLING CONTROL OFFSET” divided by 2, closing and opening of the bypass damper is allowed.
- If the “FLEX EVAP TEMP” is less than the “MX SUPPLY AIR TEMP” setpoint and the difference between the “FLEX EVAP TEMP” and the “FLEX EVAP TEMP ACTIVE SP” is more than the “COOLING CONTROL OFFSET” divided by 2 and the “FLEX EVAP TEMP” is more than “FLEX EVAP TEMP ACTIVE SP,” opening of the of the bypass damper is allowed.
- If the “FLEX EVAP TEMP” is more than the “MX SUPPLY AIR TEMP” setpoint and the difference between the “FLEX EVAP TEMP” and the “FLEX EVAP TEMP ACTIVE SP” is more than the “COOLING CONTROL OFFSET” divided by 2 and the “FLEX EVAP TEMP” is less than or equal to “FLEX EVAP TEMP ACTIVE SP,” closing of the bypass damper is allowed.
- If opening is allowed and the “RETURN AIR BYPASS CURRENT” is 2.5% more than the “RETURN AIR BYPASS ACTIVE SP,” the damper will open.
- If closing is allowed and the “RETURN AIR BYPASS CURRENT” is 2.5% less than the “RETURN AIR BYPASS ACTIVE SP,” the damper will close.
- If the “RETURN AIR BYPASS” is within plus or minus 2.5% of the “RETURN AIR BYPASS ACTIVE SP,” the damper will remain in the hold position.



$$\text{“RETURN AIR BYPASS ACTIVE SP”} = \frac{\text{“MX SUPPLY AIR TEMP”} - \text{“FLEX EVAP TEMP ACTIVE SP”}}{\text{“RETURN AIR TEMP”} - \text{“FLEX EVAP TEMP ACTIVE SP”}} * 100$$

**FORMULA 1**

$$\text{“RETURN AIR BYPASS CURRENT”} = \frac{\text{“MX SUPPLY AIR TEMP”} - \text{“FLEX EVAP TEMP”}}{\text{“RETURN AIR TEMP”} - \text{“FLEX EVAP TEMP”}} * 100$$

**FORMULA 2**

**EVAPORATOR SUPERHEAT CALCULATION**

In order to make it easier for the Service Technician to set the proper superheat at the expansion valves, the Unit Controller has the capability to calculate Evaporator Superheat.

In order to perform the calculation, the compressor system must have a suction pressure transducer installed. If the suction pressure transducer and the suction line temperature sensor are reliable the Unit Controller will display the derived “SUPERHEAT” value under the COMPRESSOR SYSTEMS key of the User Interface whenever a compressor for that system is active.

**STAGED INPUT FAULT**

This can only occur on Constant Volume units with the CONTROL METHOD set to “STAGED.” If the Unit Controller receives a digital input for either Y1 or Y2 and W1 or W2 at the same time, the Unit Controller will declare a STAGED INPUT FAULT. When a STAGED INPUT FAULT is active, the Unit Controller will lockout all cooling and heating operation. If either the Y1, Y2 or the W1, W2 digital input is removed for 10 seconds, the STAGED INPUT FAULT will be removed.

While the STAGED INPUT FAULT is active, the SENSOR / MISC STATUS subsection under the STATUS key will display “SAFETY LOCKOUT.” In addition, a “STAGED INPUT FAULT” will be recorded and displayed under the HISTORY key.

**ELECTRIC HEAT**

**Programmed Data**

The following parameters must be programmed into the Unit Controller:

- “HEATING SYSTEM” must be set to USER ENABLE through the PROGRAM key, HEATING subsection of the User Interface.

- “HEATING SYSTEM TYPE” must be set to ELECTRIC through the OPTIONS key, HEATING subsection of the User Interface.
- “ELEC HEAT CAPACITY” must be set to the nameplate capacity through the OPTIONS key, HEATING subsection of the User Interface.
- “1ST STAGE HEATING SETPOINT” must be programmed for CONSTANT VOLUME units through the SETPOINTS key, HEATING subsection of the User Interface.
- “2ND STAGE HEATING SETPOINT” must be programmed for CONSTANT VOLUME units through the SETPOINTS key, HEATING subsection of the User Interface.
- “HEATING SAT” must be programmed for Variable AIR VOLUME and FLEXSYS units through the SETPOINTS key, HEATING subsection of the User Interface.\

**Heating Control Offset**

The Unit Controller calculates a “HEAT CONTROL OFFSET” (HCO) using the following formula:

Where:

- HCO = “HEATING CONTROL OFFSET”
- KW = “ELEC HEAT CAPACITY”
- CFM = (See Table 22 on page 82)
- STAGES = Derived value based on the “ELEC HEAT CAPACITY” (See Table 23 on page 82 for number of stages)

$$\text{HCO} = \frac{\text{KW} * 3414}{2.16 * \text{CFM} * \text{STAGES}}$$

The “HEATING CONTROL OFFSET” will be rounded up to the nearest half degree. If the “HEATING CONTROL OFFSET” is calculated to be less than 2.0 °F, it will be set at 2.0 °F.

When the UNIT MODE is “COMFORT VENT HEATING,” or “SUP AIR TEMPERING” is active, the “HEATING CONTROL OFFSET” will be fixed at 5.0 °F and the heat will be staged up or down as required.

### Active SP

See Table 15 on page 62 and Table 16 on page 63 to determine what the “SUPPLY AIR TEMP ACTIVE SP” value is for CONSTANT VOLUME units.

On VARIABLE AIR VOLUME and FLEXSYS units, the “SUPPLY AIR TEMP ACTIVE SP” is the “HEATING SAT”.

### Heating Control

The Unit Controller uses the “SUPPLY AIR TEMP” as described below to determine when to cycle stages ON and OFF:

- If the “SUPPLY AIR TEMP” is less than the “SUPPLY AIR TEMP ACTIVE SP” minus the “HEATING CONTROL OFFSET,” additional stages will be brought ON after an Interstage Delay timer has expired.
- If the “SUPPLY AIR TEMP” is greater than the “SUPPLY AIR TEMP ACTIVE SP” plus the HEATING CONTROL OFFSET,” additional stages will be turned OFF after an Interstage Delay timer has expired.

TABLE 22 - CFM

UNIT SIZE	CV UNITS CFM	VAV UNITS FLEXSYS UNITS CFM
70 – 75 Ton	21000	11500
80 Ton	24000	12000
90 Ton	27000	13500
105 Ton	31000	15500

TABLE 23 - HEAT STAGES

“ELEC HEAT CAPACITY”		MAXIMUM STAGES
KW	VOLTAGE	
40	240	3
80	240	5
108	240	6
40	480	2
80	480	3
108	480	3
150	480	4
200	480	6
250	480	7

During the initial call, the Unit Controller uses the following formula to determine how many stages of electric heat to bring ON, after which the Unit Controller uses the procedure above for staging additional capacity ON or OFF.

$$N = \frac{SAT - SATSP}{2 * HCO}$$

Where:

- N = Number of Heat Stages Required (Rounded Down to the Nearest Integer)
- SAT = “SUPPLY AIR TEMP”
- SATSP = “SUPPLY AIR TEMP ACTIVE SP”
- HCO = “HEATING CONTROL OFFSET”

If the Number of Heat Stages required calculates to less than 1, the Number of Stages is set to 1.

If the Number of Heat Stages required calculates to be greater than the derived “HEAT STAGES” value, the Number of Heat Stages required will be set to the “HEAT STAGES” derived value.

When the UNIT MODE is “COMFORT VENT HEATING” or “SUP AIR TEMPERING” is active, the initial number of heating stages will not be estimated. Instead, one stage of heat will be brought ON at a time.

When UNIT MODE is “STANDBY” and “UNDER FLR TEMP OVRD” is active, one stage of heat is turned ON.

### STAGED GAS HEAT

#### Programmed Data

The following parameters are programmed into the Unit Controller:

- “HEATING SYSTEM” must be set to USER ENABLE through the PROGRAM key, HEATING subsection of the User Interface.
- “HEATING SYSTEM TYPE” must be set to STAGED GAS through the OPTOPNS key, HEATING subsection of the User Interface.
- “GAS HEAT CAPACITY” must be set to the rating plate value through the OPTIONS key, HEATING subsection of the User Interface.
- “HEAT LIMIT TEMPERATURE” must be programmed using the SETPOINTS key, HEATING subsection of the User Interface.

- “*1ST STG HEATING SETPOINT*” must be programmed for CONSTANT VOLUME units through the SETPOINTS key, HEATING subsection of the User Interface.
- “*2ND STAGE HEATING SETPOINT*” must be programmed for CONSTANT VOLUME units through the SETPOINTS key, HEATING subsection of the User Interface.
- “*HEATING SAT*” must be programmed for “*VARIABLE AIR VOLUM*” and “*FLEXSYS*” units through the SETPOINTS key, HEATING subsection of the User Interface.

### Heating Control Offset

The Unit Controller calculates a “HEAT CONTROL OFFSET” (HCO) using the following formula:

$$HCO = \frac{180000}{2.16 * CFM}$$

**TABLE 24 - CFM**

CV UNITS CFM	UNIT SIZE	VAV UNITS FLEXSYS UNITS CFM
21000	70 – 75 Ton	11500
24000	80 Ton	12000
27000	90 Ton	13500
31000	105 Ton	15500

**TABLE 25 - HEAT STAGES**

“GAS HEAT CAPACITY” (MBH)	MAXIMUM STAGES
375	2
750	4
1125	6

Where:

- HCO = “*HEAT CONTROL OFFSET*”
- CFM = (See *Table 24 on page 83*)

The “*HEAT CONTROL OFFSET*” will be rounded up to the nearest half degree. If the “*HEAT CONTROL OFFSET*” is calculated to be less than 2.0 °F, it will be set at 2.0 °F.

When the UNIT MODE is “*COMFORT VENT HEATING*” and active, the “*HEATING CONTROL OFFSET*” will be fixed at 5.0 °F and the heat will be staged up or down as required.

### Active SP

See *Table 15 on page 62* and *Table 16 on page 63* to determine what the “*SUPPLY AIR TEMP ACTIVE SP*” value is for CONSTANT VOLUME units.

On “*VARIABLE AIR VOLUM*” and “*FLEXSYS*” units, the “*SUPPLY AIR TEMP ACTIVE SP*” is the “*HEATING SAT*”.

### Heating Control

The Unit Controller uses the “*SUPPLY AIR TEMPERATURE*” as described below to determine when to cycle stages ON and OFF.

- If the “*SUPPLY AIR TEMP*” is less than the “*SUPPLY AIR TEMP ACTIVE SP*” minus the “*HEATING CONTROL OFFSET*,” additional stages will be brought ON after an Interstage Delay timer has expired.
- If the “*SUPPLY AIR TEMP*” is greater than the “*SUPPLY AIR TEMP ACTIVE SP*” plus the “*HEATING CONTROL OFFSET*,” additional stages will be turned OFF after an Interstage Delay timer has expired.
- If the “*SUPPLY AIR TEMP*” plus 2 x the “*HEATING CONTROL OFFSET*” is more than or equal to the “*HEAT LIMIT TEMPERATURE*,” the Unit Controller will prevent any heat stages from being energized.

$$N = \frac{SAT - SATSP}{2 * HCO}$$

During the initial call, the Unit Controller uses the following formula to determine how many stages of gas heat to bring ON, after which the Unit Controller uses the procedure above for staging ON or OFF additional capacity:

Where:

- N = Number of Heat Stages Required (Rounded Down to the Nearest Integer)
- SAT = “*SUPPLY AIR TEMP*”
- SATSP = “*SUPPLY AIR TEMP ACTIVE SP*”
- HCO = “*HEATING CONTROL OFFSET*”

If the Number of Heat Stages required calculates to less than 1, the Number of Stages is set to 1.

If the Number of Heat Stages required calculates to be greater than the derived “*HEAT STAGES*” value the Number of Heat Stages required will be set to the “*HEAT STAGES*” derived value.

When the UNIT MODE is “*COMFORT VENT HEATING*” or “*SUP AIR TEMPERING*” is active, the initial number of heating stages will not be estimated. Instead, one stage of heat will be brought ON at a time.

When UNIT MODE is “*STANDBY*” and “*UNDER FLR TEMP OVRD*” is active, one stage of heat is turned “ON”.

### Staged Gas Heat Mode of Operation Status

The Unit Controller monitors the time it takes to go between stages of operation (prepurge, ignition, on, purge, etc.) and the specified operating state (off, low fire, high fire) to monitor and display the current mode of operation for each gas heat sections.

The following information can be viewed for each of the gas heat sections (“*FURNACE 1 MODE*,” “*FURNACE 2 MODE*,” “*FURNACE 3 MODE*”) by pressing the HEATING key of the User Interface:

- OFF
- PURGE
- IGNITION
- ON-LOW
- ON-HIGH
- SAFETY TRIP
- SAFETY FAULT
- SAFETY LOCKOUT
- FAULT - L/O

“*FURNACE 1 MODE*,” “*FURNACE 2 MODE*,” or “*FURNACE 3 MODE*” will be determined as follows:

- If the “*GAS HEAT CAPACITY*” is set to 375 MBH, the display shall show the “*FURNACE 1 MODE*” data.
- If the “*GAS HEAT CAPACITY*” is set to 750 MBH, the display shall show the “*FURNACE 1 MODE*” and “*FURNACE 2 MODE*” data.
- If the “*GAS HEAT CAPACITY*” is set to 1125 MBH, the display shall show the “*FURNACE 1 MODE*,” “*FURNACE 2 MODE*,” and “*FURNACE 3 MODE*” data.

When a heating fault is registered by the Unit Controller, the control turns off the gas heat operation for that section and places that gas heat section in a “*SYSTEM LOCKOUT*” mode. The Unit Controller then initiates a call to the next available heating section.

The “*SYSTEM LOCKOUT*” will remain in effect for 1 hour or until the Unit Controller is reset. A “*SYSTEM LOCKOUT*” can be reset by turning the “*LOCAL*”

“*STOP*” switch OFF for 5 seconds and then back ON or by switching the “*HEATING SYSTEM*” parameter from “*USER ENABLED*” to “*USER DISABLED*” for 5 seconds and then back to “*USER ENABLED*.” This can be done through the PROGRAM key, HEATING subsection of the User Interface. The faulted heat section will then initiate an ignition sequence, provided the heating demand is still present.

### Staged Gas Heat Ignition Sequence

1. The Unit Controller sends a 24-volt signal to the furnace section ignition control from terminal block TB3 Terminals 2, 4, or 7.
2. The furnace section ignition control sends a 230-volt signal to the inducer motor.
3. When the inducer comes up to speed, the heat section pressure switch closes.
4. The ignition control waits 30 seconds and then starts a high voltage spark for 7 seconds. This allows for a prepurge of the heat exchanger.
5. At the same time, the ignition control sends a 24-volt signal to low fire solenoid of the gas valve.
6. The ignition control then checks for a flame rectification signal. If the signal is present for 15 seconds, an analog signal is sent to the Unit Controller identifying proper operation of the heat section. The 0.0- to 5.0-volt signal enters the Unit Controller through pin 18 of the J5 connector.
7. If ignition control does not receive a flame rectification signal in 7 seconds, it closes the gas valve, turns off the spark and waits 30 seconds.
8. The ignition control then energizes the gas valve and initiates the spark for a second ignition sequence. If flame rectification is recognized for 15 seconds, an analog signal is sent to the Unit Controller identifying proper operation of the heat section. The 0.0- to 5.0-volt signal enters the Unit Controller through pin 18 of the J5 connector.
9. If the ignition control does not receive a flame rectification signal in 7 seconds, it closes the gas valve, turns off the spark and waits 30 seconds.
10. The ignition control then energizes the gas valve and initiates the spark for a third ignition sequence. If flame rectification is recognized for 15 seconds, an analog signal is sent to the Unit Controller identifying proper operation of the heat section. The 0.0- to 5.0-volt signal enters the Unit Controller through pin 18 of the J5 connector.

11. If the ignition control does not receive a flame rectification signal in 7 seconds, it closes the gas valve, turns off the inducer, and locks out the operation of that heat section. The heat section remains locked out until the 24-volt power to the ignition control is removed, or 1 hour, whichever occurs first.
12. The Unit Controller will then try to energize the next available heat section and will show the status of that heat section as "SAFETY LOCKOUT."
13. If the "SUPPLY AIR TEMP" continues to be less than the "SUPPLY AIR TEMP ACTIVE SP" minus the "HEATING CONTROL OFFSET," the Unit Controller energizes the high fire solenoid of the gas valve and the heat section switches to high fire operation. This 24-volt signal originates at terminal block TB-3, Terminals 3, 5, or 8 of the Unit Controller.
14. If the "SUPPLY AIR TEMP" continues to be less than the "SUPPLY AIR TEMP ACTIVE SP" minus the "HEATING CONTROL OFFSET" additional gas heat sections, if available, are energized. The sequence of operation for the additional heat sections is the same as discussed above.

## MODULATING GAS HEAT

### Overview

Modulating gas heat can be ordered with a minimum of two gas heat stages (1 heat exchanger section) and a maximum of 6 stages (three heat exchanger sections).

Figure 32 on page 85 shows the staging sequence for the modulating heat stages. As can be seen from the chart, Heat section 1A (modulating) is always the first section ON and the last section OFF. Heat section 1B is always the last section ON and the first section OFF. The number of stages between 1A and 1B operation is depended on the number of heating sections installed in the unit. The modulating heat section, 1A, must always modulate to full fire before any additional stages can be brought ON. When additional stages are required, the modulating heat section will go to minimum fire and the next stage of heating will be brought ON. If there continues to be a demand for additional heat, the modulating heat section remodulates to high fire before any additional stages can come ON. During a decrease in heating demand, the modulating heat section must be at a minimum fire condition before any stages are turned OFF.

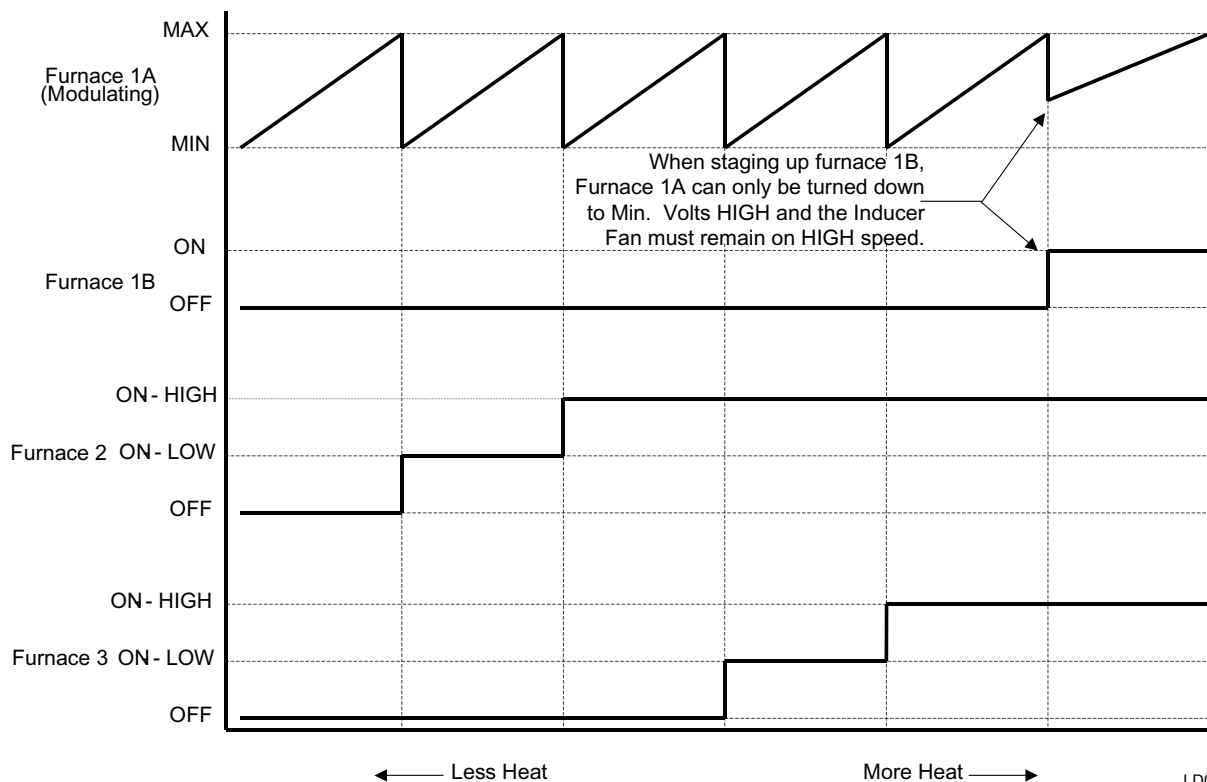

FIGURE 32 - MODULATING GAS HEAT STAGING SEQUENCE

## Programmed Data

The following parameters are programmed into the Unit Controller:

- “HEATING SYSTEM” must be set to USER ENABLE through the PROGRAM key, HEATING subsection of the User Interface.
- “HEATING SYSTEM TYPE” must be set to “MODULATING GAS” through the OPTIONS key, HEATING subsection of the User Interface.
- “GAS HEAT CAPACITY” must be set to the rating plate value through the OPTIONS key, HEATING subsection of the User Interface.
- “HEAT LIMIT TEMPERATURE” must be programmed using the SETPOINTS key, HEATING subsection of the User Interface.
- “1ST STAGE HEATING SETPOINT” must be programmed for CONSTANT VOLUME units through the SETPOINTS key, HEATING subsection of the User Interface.
- “2ND STAGE HEATING SETPOINT” must be programmed for CONSTANT VOLUME units through the SETPOINTS key, HEATING subsection of the User Interface.
- “HEATING SAT” must be programmed for “VARIABLE AIR VOLUM” and “FLEXSYS” units through the SETPOINTS key, HEATING subsection of the User Interface.

## Active SP

See Table 15 on page 62 and Table 16 on page 63 to determine what the “SUPPLY AIR TEMP ACTIVE SP” value is for CONSTANT VOLUME units.

On Variable AIR VOLUME and FLEXSYS units, the “SUPPLY AIR TEMP ACTIVE SP” is the “HEATING SAT.”

The modulating heat becomes active as soon as the unit transitions into an OCCUPIED HEATING or UNOCCUPIED HEATING mode.

## Heating Control Offset

The Unit Controller uses the “SUPPLY AIR TEMP” as described below, to determine when to increase or decrease the heating capacity:

- If the “SUPPLY AIR TEMP” is less than the “SUPPLY AIR TEMP ACTIVE SP” minus the “HEATING CONTROL OFFSET,” the Unit Controller will be set to the Increase Mode.

- If the “SUPPLY AIR TEMP” is greater than the “SUPPLY AIR TEMP ACTIVE SP” plus or minus the “HEATING CONTROL OFFSET,” the Unit Controller will be set to the Decrease Mode.
- If the “SUPPLY AIR TEMP” is within the range of the “SUPPLY AIR TEMP ACTIVE SP” +/- the “HEATING CONTROL OFFSET,” the Unit Controller will be set to the Hold Mode.
- The “HEATING CONTROL OFFSET” is programmed at 1 1/2 °F.
- If the “UNDER FLR TEMP OVRD” is active, the unit will be modulated to the “UNDERFLOOR TEMP CONTROL SP” ± the “HEATING CONTROL OFFSET”.

## Modulating Step Size

During the modulating sequence of furnace Section 1A the Heating Valve is stepped UP or DOWN as required. The amount or magnitude of each step increment is determined using the following equation:

$$\text{STEP} = \frac{\text{VHIGH} - \text{VLOW}}{\text{INCREMENTS}} \quad (1)$$

And

$$\text{INCREMENTS} = \frac{\text{RAMPTIME}}{\text{CYCLETIME}} \quad (2)$$

Where:

- STEP = Step Voltage of the HEATING VALVE (VDC)
- VHIGH = Programmed Variable Maximum Voltage High (VDC) - 8.5 volts high fire, 6.0 volts low fire
- VLOW = Programmed Variable Minimum Voltage Low (VDC) - 4.0 volts high fire, 1.0 volt low fire
- RAMPTIME = Time required to modulate HEATING VALVE from Minimum to Maximum
- CYCLE TIME = Algorithm Cycle Time

RAMPTIME will vary based on the difference between the “SUPPLY AIR TEMP” and the “SUPPLY AIR TEMP ACTIVE SP.” If the difference is large, the RAMPTIME shall be relatively fast. If the difference is small, the RAMPTIME shall be relatively slow. The following chart shows the relationship between RAMPTIME and SAT error (difference between the “SUPPLY AIR TEMP” and the “SUPPLY AIR TEMP ACTIVE SP”).

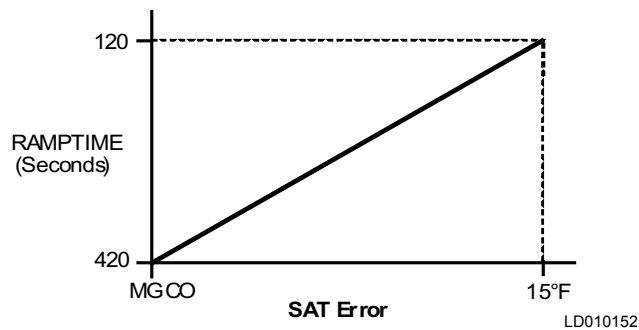

**FIGURE 33 - SAT ERROR**

### Modulating Gas Heat Mode of Operation Status

The Unit Controller monitors the time it takes to go between stages of operation (purge, ignition, on, etc.) and the specified operating state (off, low fire, high fire) to monitor and display the current mode of operation for each gas heat sections.

The following information can be viewed for each of the gas heat sections (“FURNACE 2 MODE,” “FURNACE 3 MODE”) by pressing the HISTORY key of the User Interface:

- OFF
- PURGE
- IGNITION
- ON-LOW
- ON-HIGH
- SAFETY TRIP
- SAFETY FAULT
- SAFETY LOCKOUT
- FAULT - L/O

The following information is displayed for gas heat sections “FURNACE 1A MODE” and “FURNACE 1B MODE”:

- OFF
- PURGE
- IGNITION
- ON
- SAFETY TRIP
- SAFETY FAULT
- SAFETY LOCKOUT
- FAULT - L/O

“FURNACE 1A, 1B, 2, OR 3 MODE” will be determined as follows:

- If the “GAS HEAT CAPACITY” is set to 375 MBH, the display shall show the “FURNACE 1A MODE” and “FURNACE 1B MODE” data.
- If the “GAS HEAT CAPACITY” is set to 750 MBH, the display shall show the “FURNACE 1A MODE,” “FURNACE 1B MODE” and “FURNACE 2 MODE” data.
- If the “GAS HEAT CAPACITY” is set to 1125 MBH, the display shall show the “FURNACE 1A MODE,” “FURNACE 1B MODE,” “FURNACE 2 MODE,” and “FURNACE 3 MODE” data.

When a heating fault is registered by the Unit Controller, the control turns off the gas heat operation for that section and places that gas heat section in a “SYSTEM LOCKOUT” mode. The Unit Controller then initiates a call to the next available heating section. The “SYSTEM LOCKOUT” will remain in effect for one hour or until the Unit Controller is reset. A “SYSTEM LOCKOUT” can be reset by turning the “LOCAL STOP” switch OFF for 5 seconds and then back ON or by switching the “HEATING SYSTEM” parameter from “USER ENABLED” to “USER DISABLED” for 5 seconds and then back to “USER ENABLED”. This can be done through the PROGRAM key HEATING subsection of the User Interface. The faulted heat section will then initiate an ignition sequence, provided the heating demand is still present. If furnace section 1A is in a “SYSTEM LOCKOUT” mode furnace section 1B will also be locked out.

### Furnace Ignition Sequence

1. The Unit Controller sends a 24-volt signal to start heat section 1A heat section through terminal block TB3 - Terminal 2.
2. The Unit Controller sends a 24-volt signal to place the inducer and gas valve on high fire through terminal block TB3 – Terminal 3.
3. When the inducer comes up to speed the low fire and high fire pressure switches closes.
4. The ignition control waits 30 seconds and then starts a high voltage spark for 7 seconds. The 30 seconds delay allows for a prepurge of the heat exchanger.
5. At the same time, the ignition control sends a 24-volt signal to the low and high fire solenoids of the gas valve and ramps the modulating gas valve to minimum high fire.

6. The ignition control then checks for a flame rectification signal, if the signal is present for 15 seconds, an analog signal is sent to the Unit Controller identifying proper operation of the heat section. The 0.0- to 5.0-volt signal enters the Unit Controller through pin 18 of the J5 connector.
7. If the ignition control does not receive a flame rectification signal in 7 seconds, it closes the gas valve, turns off the spark and waits 30 seconds.
8. The ignition control then energizes the gas valve and initiates the spark for a second ignition sequence. If flame rectification is recognized for 15 seconds, an analog signal is sent to the Unit Controller identifying proper operation of the heat section. The 0.0- to 5.0-volt signal enters the Unit Controller through pin 18 of the J5 connector.
9. If the ignition control does not receive a flame rectification signal in 7 seconds, it closes the gas valve, turns off the spark and waits 30 seconds.
10. The ignition control then energizes the gas valve and initiates the spark for a third ignition sequence. If flame rectification is recognized for 15 seconds, an analog signal is sent to the Unit Controller identifying proper operation of the heat section. The 0.0- to 5.0-volt signal enters the Unit Controller through pin 18 of the J5 connector.
11. If the ignition control does not receive a flame rectification signal in 7 seconds it closes the gas valve, turns off the inducer, and places the 1A and 1B heat sections in a “*SYSTEM LOCKOUT*”.
12. The Unit Controller will then try to energize the next available heat section.
13. If the ignition module receives a rectification signal for 15 seconds the Unit Controller switches the inducer to low speed, turns off the high fire solenoid and ramps the modulating gas valve to minimum low fire.
14. The 1A heat section is now in the modulating mode of operation.
15. If the Unit Controller is in the increase mode it will ramp up the modulating gas valve to high low fire. The Unit Controller then energizes the inducer on high speed and energizes the high fire solenoid of the gas valve. The 1A heat section is now in the high fire mode of operation.
16. If the Unit Controller continues in the increase mode it will ramp the gas valve up to maximum high fire mode of operation.
17. If the Unit Controller continues in the increase mode and the modulating gas valve has been at maximum high fire for 30 seconds, it will then bring ON the staged heat sections 2 and/or 3 if available. As soon as the Unit Controller receives conformation of heat section 2 or 3 operation, it will modulate the 1A heat section back down to minimum low fire.
18. The modulating heat section must modulate from the minimum low fire to the maximum high fire and maintain maximum high fire operation for 30 seconds between each step of the staged operation.
19. After all the available staged heating capacity is energized and the 1A heat section is at maximum high fire and there is a call for additional capacity, the Unit Controller ramps the modulating gas valve to minimum high fire and starts the ignition sequence of the 1B heat section. This ignition sequence is the same as staged gas heat.
20. If additional capacity is required, the modulating 1A heat section will ramp up to maximum high fire.
21. At this point, the unit is operating at its maximum heat capacity.
22. The de-staging sequence is the reserves of the above sequence with the requirement that the modulating heat section (1A) must always but at minimum low fire before another heat section is turned OFF.

## HOT WATER/STEAM HEAT

### Programmed Data

The following parameters are programmed into the Unit Controller:

- “*HEATING SYSTEM*” must be set to USER ENABLE through the PROGRAM key, HEATING subsection of the User Interface.
- “*HEATING SYSTEM TYPE*” must be set to HOT WATER HEAT / STEAM through the OPTIONS key, HEATING subsection of the User Interface.
- “*HW VALVE ACTION*” must be set to “*DI-RECT*” OR REVERSE” through the PROGRAM key, HEATING subsection of the User Interface.
- “*1ST STAGE HEATING SETPOINT*” must be programmed for CONSTANT VOLUME units through the SETPOINTS key, HEATING subsection of the User Interface.



- “*2ND STAGE HEATING SETPOINT*” must be programmed for CONSTANT VOLUME units through the SETPOINTS key, HEATING subsection of the User Interface.
- “*HEATING SAT*” must be programmed for “*VARIABLE AIR VOLUM*” and “*FLEXSYS*” units through the SETPOINTS key, HEATING subsection of the User Interface.

### Active SP

See Table 15 on page 62 and Table 16 on page 63 to determine what the “*SUPPLY AIR TEMP ACTIVE SP*” value is for CONSTANT VOLUME units.

On “*VARIABLE AIR VOLUM*” and “*FLEXSYS*” units the “*SUPPLY AIR TEMP ACTIVE SP*” is the “*HEATING SAT*.”

The STEAM or HOT WATER heat becomes active as soon as the unit transitions into an OCCUPIED HEATING or UNOCCUPIED HEATING mode.

### Sequence of Operation

The Unit Controller uses the “*SUPPLY AIR TEMP*” as described below to determine when to increase or decrease the heating capacity:

- If the “*SUPPLY AIR TEMP*” is less than the “*SUPPLY AIR TEMP ACTIVE SP*,” the Unit Controller will increase the amount of heat.
- If the “*SUPPLY AIR TEMP*” is greater than the “*SUPPLY AIR TEMP ACTIVE SP*,” the Unit Controller will decrease the amount of heat.
- When “*UNDER FLR TEMP OVRD*” is active, the valve is controlled to “*UNDERFLOOR TEMP CONTROL SP*”.

The Unit Controller sends a 0- to 10-VDC signal to the hot water or steam valve as described below:

- If the unit is configured for “*DIRECT*,” an increase in heating demand results in an increase in output voltage to the valve.
- If the unit is configured for “*REVERSE*,” an increase in heating demand results in a decrease in output voltage to the valve.

### Freeze Protection

If the control is not in an active heating mode but the Supply Fan Air Proving Switch is closed, the Unit Controller will control the modulating valve to prevent the supply air temperature from dropping below 38.0 °F.

If the Supply Fan Air Proving Switch is open (unit OFF) and the Outdoor Air Temperature is less than 40.0 °F, a voltage signal will be sent to the modulating valve to open to 100% or 0% if the valve Action is programmed for “*REVERSE*.”

### Freeze Fault

The Unit Controller monitors the status of the “*HW / STEAM FRZ STATUS*” through terminal block TB7 Terminal 14. If 24 volts is present, closed contact, for 10 seconds a voltage signal will be sent to the modulating valve to open to 100% or 0 % if the valve Action is programmed for “*REVERSE*” The Primary Control will start a 5 minute Freeze Trip Timer. The freeze stat closes at 35.0 °F. The STATUS screen of the User Interface will display “*SENSOR / MISC STATUS SAFETY TRIP*” and the HISTORY screen will show “*WRN TRIP FREEZESTAT*.”

If the “*HW / STEAM FRZ STATUS*” goes low, open contact, during this period the Unit Controller will resume normal operation.

If the “*HW / STEAM FRZ STATUS*” remains high, closed contact, at the end of this period the Unit Controller will shut the unit down and generate a “*LOCKOUT HOT WATER FREEZE*” fault. The STATUS screen of the User Interface will display “*SENSOR / MISC STATUS SAFETY LOCKOUT*” and “*UNIT OVERALL – UNIT LOCKOUT*.” The HISTORY screen will show “*LOCKOUT HOT WATER FREEZE*.”

### MORNING WARM UP

Morning Warm Up can be initiated in three ways:

1. Hardwired digital signal to the W1 input.
2. A Morning Warm Up command from a BAS system.
3. Self initiated through the internal “*ADAPTIVE MORN WARM UP ACTIVE*” mode.

The Morning Warm Up operation will be the same for all unit configurations except Constant Volume units using the Staged Control option. Constant Volume units using Staged Control will never enter Morning Warm Up.

Morning Warm Up function will be active if the following conditions are met:

- “*MORNING WARM UP*” is set to USER ENABLED. “*MORNING WARM UP*” can be found under the PROGRAM key, HEATING subsection of the User Interface.

- The Occupancy mode is UNOCCUPIED STANDBY.
- And one of the following is true:
  1. There is a W1 input.
  2. A Morning Warm Up command is received from a BAS system.

Morning Warm Up function will be inactive if any of the following conditions are met:

- “*MORNING WARM UP*” is set to USER DISABLED.
- The occupancy mode is OCCUPIED.
- The W1 low heat input is lost or the Morning Warm Up command from a BAS system is lost.

### Sequence of Operation

1. The return fan starts.
2. After 5 minutes, the Unit Controller compares the Return Air Temperature to the “RAT HEATING SETPOINT”.
3. If the Return Air Temperature is greater than the “RAT HEATING SETPOINT” minus 1.0 °F, the Unit Controller will not energize the heating sequence.
4. If the Return Air Temperature is less than or equal to the “RAT HEATING SETPOINT” minus 1.0 °F the Unit Controller will energize the heating sequence.
5. The Unit Controller sets the “SUPPLY AIR TEMP ACTIVE SP” as follows:
  - VARIABLE AIR VOLUME AND FLEXSYS units - “HEATING SAT.”
  - CONSTANT VOLUME units - “2ND STAGE HEATING SETPOINT.”
6. The heat source remains energized until the Return Air Temperature is greater than or equal to the “RAT HEATING SETPOINT” plus 0.5 °F or the morning warm up command is removed or the unit switches to occupied mode.

### ADAPTIVE MORNING WARM UP

Adaptive Morning Warm Up can only be used when the internal Schedule function is employed to switch the unit from Unoccupied to Occupied mode. The Unit Controller calculates the start time for the heat to en-

sure the Return Air Temperature is within 0.5 °F of the “*RAT HEATING SETPOINT*” when the unit switches to the occupied mode. To do this, the Unit Controller calculates the “*MORNING WARM UP OPT TIME*” by averaging the time it takes to bring the “*RETURN AIR TEMP*” to within 0.5 °F of the “*RAT HEATING SETPOINT*” for three consecutive days. The three warm up times are averaged and added to a 10-minute offset. The new time is used as the “*MORNING WARM UP OPT TIME*” for the next day.

In order to use Adaptive Morning Warm Up the Primary Control must be configured as follows:

- The “*OCCUPANCY SCHEDULE*” must be programmed for the Occupied, Unoccupied start and stop times. This is done through the SCHEDULE key of the User Interface.
- The “*OCCUPANCY SCHEDULE*” must be USER ENABLED. This is done through the SCHEDULE key of the User Interface.
- “*MORNING WARM UP*” must be set to USER ENABLED. This can be done through the PROGRAM key HEATING subsection of the User Interface.
- “*ADAPT MORN WARM UP*” must be set to USER ENABLED. This can be done through the PROGRAM key HEATING subsection of the User Interface.
- “*RAT HEATING SETPOINT*” must be set. This can be done through the SETPOINTS key HEATING subsection of the User Interface.
- “*MORNING WARM UP MAX TIME*” must be set. This can be done through the SETPOINTS key HEATING subsection of the User Interface.

The following limitations apply:

- If the “*MORNING WARM UP OPT TIME*” exceeds the “*MORNING WARM UP MAX TIME*” the “*MORNING WARM UP OPT TIME*” shall be “*MORNING WARM UP MAX TIME*”.
- If the “*MORNING WARM UP OPT TIME*” is determined to be less than 15 minutes, the “*MORNING WARM UP OPT TIME*” shall be set to 15 minutes.
- The default values for “*DAILY WARM UP TIME DAY 1*”, “*DAILY WARM UP TIME DAY 2*”, and “*DAILY WARM UP TIME DAY 3*” shall initially be set at 60 minutes. These values can be reset to

the default values by turning the “*MORN WARM UP*” to USER DISABLED and then back USER ENABLED.

### Sequence of Operation

1. The return fan starts.
2. After 5 minutes, the Unit Controller compares the Return Air Temperature to the “RAT HEATING SETPOINT”.
3. If the Return Air Temperature is greater than the “RAT HEATING SETPOINT” minus 1.0 °F, the Unit Controller will not energize the heating sequence and it sets the daily warm up time to 5 minutes.
4. If the Return Air Temperature is less than or equal to the “RAT HEATING SETPOINT” minus 1.0 °F the Unit Controller will energize the heating sequence based on the “MORNING WARM UP OPTIME”.
5. The Unit Controller sets the “*SUPPLY AIR TEMP ACTIVE SP*” as follows:
  - VARIABLE AIR VOLUME and FlexSys units it is the “*HEATING SAT.*”
  - CV units it is the “*2ND STAGE HEATING SETPOINT.*”
6. The heat source remains energized until the Return Air Temperature is more than or equal to the “*RAT HEATING SETPOINT*” plus 0.5° F or the unit goes into the occupied mode.
7. The Unit Controller records the time the heat source is energized as described below:

If the heat source was terminated because it was within 0.5 °F of the “*RAT HEATING SETPOINT*” the Unit Controller replaces the Day 3 time with the Day 2 time; the Day 2 times with the Day 1 time and replaces the Day 1 time with the current value. It then averages the three values and adds 10 minutes and this becomes the new “*MORNING WARM UP OPT TIME*” for the next day.

If the heat source does not bring the “*RETURN AIR TEMP*” up to the “*RAT HEATING SETPOINT*” before the Morning Warm Up is stopped, the Unit Controller calculates a approximate daily warm up time using the following formula:

$$= \left\{ \begin{array}{c} \text{TIME} \\ \text{TEMP 2} - \\ \text{TEMP 1} \end{array} \right\} * (\text{Setpoint} - \text{Temp1})$$

Where:

- Warm Up time = time to be recorded as the Daily Warm Up Time
- Time = Elapsed time when Warm Up Stopped
- TEMP2 = “*RETURN AIR TEMP*” when the Warm Up stopped
- TEMP1 = “*RETURN AIR TEMP*” when the Warm Up started
- Setpoint = “*RAT HEATING SETPOINT*”
  - If the time from when heat is started and Morning Warm Up is stopped is less than 10 minutes, the Unit Controller will use the daily warm up time for the previous day and will not approximate a warm up time.
  - If the approximate daily warm up time exceeds the “*MORNING WARM UP MAX TIME*”, the daily warm up time will be set equal to the “*MORNING WARM UP MAX TIME*”.

### FLEXSYS UNDER FLOOR TEMPERATURE CONTROL

#### Programmed Data

The following parameters must be programmed into the Unit Controller:

- “*ACTIVE SLAB CONTROL*” must be set to USER ENABLED under the PROGRAM key, COOLING subsection of the User Interface.
- “*DEW POINT RESET*” must be set to USER ENABLED under the PROGRAM key, COOLING subsection of the User Interface.
- “*HEATING SYSTEM*” must be set to USER ENABLED under the PROGRAM key, HEATING subsection of the User Interface.

**Under Floor Heating Sequence of Operation****Occupied Standby**

1. The Unit Controller checks the “*UNDERFLOOR SLAB TEMP*” immediately after transitioning from Unoccupied to Occupied Standby mode.
2. If the “*UNDERFLOOR SLAB TEMP*” is less than or equal to the “*MX SUPPLY AIR TEMP SETPOINT*” minus 2.0 °F, the “*UNDER FLR TEMP OVRD*” shall be set to active.
3. The “*UNDERFLOOR TEMP CONTROL SP*” is set to the “*MX SUPPLY AIR TEMP SETPOINT*” plus 10.0 °F.
4. The Unit Controller then generates a call for one stage of heat for staged heat operation or controls the “*SUPPLY AIR TEMPERATURE*” to the “*UNDERFLOOR TEMP CONTROL SP*” for modulating heat.
5. Heating operation will continue until:
  - The “*UNDERFLOOR SLAB TEMP*” rises to or above the “*MX SUPPLY AIR TEMP SETPOINT*,” or
  - 20 minutes has elapsed.

**Unoccupied Standby**

1. The Unit Controller checks the “*UNDERFLOOR SLAB TEMP*” immediately after transitioning from Occupied to Unoccupied Standby mode.
2. If the “*UNDERFLOOR SLAB TEMP*” is less than the “*RETURN AIR TEMP*” minus 2.0 °F, the “*UNDER FLR TEMP OVRD*” shall be set to Active.
3. The “*UNDERFLOOR TEMP CONTROL SP*” is set to the present instantaneous “*RETURN AIR TEMP*” plus 10.0 °F.
4. The Unit Controller then generates a call for one stage of heat for staged heat operation or controls the “*SUPPLY AIR TEMPERATURE*” to the “*UNDERFLOOR TEMP CONTROL SP*” for modulating heat.
5. Heating operation will continue until:
  - The “*UNDERFLOOR SLAB TEMP*” rises to or above the “*RETURN AIR TEMP*” plus 1.0 °F, or
  - 20 minutes has elapsed.

**Dew Point Reset Sequence of Operation**

The Unit Controller uses the “*SUPPLY AIR TEMP*” and the “*UNDERFLOOR AIR HUMIDITY*” to calculate the “*UNDERFLOOR SLAB DEW POINT*”.

If the “*UNDERFLOOR SLAB DEW POINT*” is greater than or equal to the “*UNDERFLOOR SLAB TEMP*” minus 2.0 °F for 120 seconds, the Unit Controller will switch to the “*EVAP LEAVING AIR TEMP LOW*” setpoint.

**EXHAUST FAN OPERATION****On/Off Control Based On Damper Position****Required Programmed Values**

“*POWER EXHAUST TYPE*” must be set to “*ON-OFF DAMPER CONTROL*” through the OPTIONS key, EXHAUST subsection of the User Interface.

“*ECONO OUPUT FOR FAN START*” must be set using the SETPOINTS key, EXHAUST subsection of the User Interface.

“*ECONO OUPUT FOR FAN STOP*” must be set using the SETPOINTS key, EXHAUST subsection of the User Interface.

**Operation**

This option is only available on Constant Volume units. The fixed speed motor is turned ON and OFF based on the position of the outside air damper. The Exhaust Motor is turned ON when the damper position is more than or equal to the “*ECONO OUTPUT FOR FAN START*” setting and turns off when the damper position is less than or equal to the “*ECONO OUTPUT FOR FAN STOP*”.

**On/Off Control Based On Building Pressure****Required Programmed Values**

“*POWER EXHAUST TYPE*” must be set to “*ON-OFF PRESS CONTROL*” through the OPTIONS key, EXHAUST subsection of the User Interface.

“*BUILDING PRESSURE ACTIVE SETPOINT*” must be set using the SETPOINTS key, EXHAUST subsection of the User Interface.

“*BLDG PRESSURE CNTRL OFFSET*” must be set using the SETPOINTS key, EXHAUST subsection of the User Interface.

### Operation

This option is available on all units. The fixed speed exhaust motor is turned ON and OFF based on the building pressure. When the Building Static Pressure input is equal to or greater than the “*BUILDING PRESSURE SETPOINT*” plus the “*BLDG PRESSURE CNTL OFFSET*,” the exhaust fan will turn ON. When the Building Static Pressure input is equal to or less than the “*BUILDING PRESSURE SETPOINT*” minus the “*BLDG PRESSURE CNTL OFFSET*,” the exhaust fan will turn OFF.

### Modulating Damper with Fixed Speed Exhaust

#### Required Programmed Values

“*POWER EXHAUST TYPE*” must be set to “*MODULATE DAMPER - VFD*” through the OPTIONS key, EXHAUST subsection of the User Interface.

“*BUILDING PRESSURE SETPOINT*” must be set using the SETPOINTS key, EXHAUST subsection of the User Interface.

“*EXHAUST OUTPUT FOR FAN START*” must be set using the SETPOINTS key, EXHAUST subsection of the User Interface.

“*EXHAUST OUTPUT FOR FAN STOP*” must be set using the SETPOINTS key, EXHASUT subsection of the User Interface.

### Operation

This option is available on all units. A variable voltage analog output from the Unit Controller controls the position of the exhaust damper. The output is based on the difference between the actual building pressure and “*BUILDING PRESSURE SETPOINT*”. If the actual building pressure is greater than the “*BUILDING PRESSURE SETPOINT*,” the Unit Controller will initiate a voltage ramp to the exhaust damper. The rate at which the (voltage) increases will vary based on the difference between the actual building pressure and the “*BUILDING PRESSURE SETPOINT*.” The User Interface will show this output as a %. 0 volts is 0% and 10 volts is 100%. This output can be found at terminals 3 and 4 of terminal block TB9 of the Unit Controller.

When the percentage output to the exhaust damper is more than or equal to the “*EXHAUST OUTPUT FOR FAN START*,” the Unit Controller will send a binary signal to the exhaust motor and the motor will start.

This binary output originates at terminal 4 of terminal block TB1 of the Unit Controller.

The exhaust damper will then modulate to maintain the “*BUILDING PRESSURE SETPOINT*”.

When the percentage output to the exhaust damper is less than or equal to the “*EXHAUST OUTPUT FOR FAN STOP*,” the Unit Controller will remove the binary signal to the exhaust motor and the motor will stop.

### Modulating Exhaust with A VFD

#### Required Programmed Values

“*POWER EXHAUST TYPE*” must be set to “*MODULATE DAMPER - VFD*” through the OPTIONS key, EXHAUST subsection of the User Interface.

“*BUILDING PRESSURE SETPOINT*” must be set using the SETPOINTS key, EXHAUST subsection of the User Interface.

“*EXHAUST OUTPUT FOR FAN START*” must be set using the SETPOINTS key, EXHAUST subsection of the User Interface.

“*EXHAUST OUTPUT FOR FAN STOP*” must be set using the SETPOINTS key, EXHASUT subsection of the User Interface.

### Operation

This option is available on all units. A variable voltage analog output from the Unit Controller varies the speed of the VFD exhaust motor. The output is based on the difference between the actual building pressure and “*BUILDING PRESSURE SETPOINT*.” If the actual building pressure is greater than the “*BUILDING PRESSURE SETPOINT*” the Unit Controller will initiate a voltage ramp to the VFD. The rate at which the (voltage) increases will vary based on the difference between the actual building pressure and the “*BUILDING PRESSURE SETPOINT*”. The User Interface will show this output as a %. 0 volts is 0% and 10 volts is 100%. This output can be found at terminals 3 and 4 of terminal block TB9 of the Unit Controller.

When the percentage output to the VFD is more than or equal to the “*EXHAUST OUTPUT FOR FAN START*” the Unit Controller will send a binary signal to the exhaust fan VFD and the motor will start. This binary output originates at terminal 4 of terminal block TB1 of the Unit Controller.

The speed of the VFD will then modulate to maintain the “*BUILDING PRESSURE SETPOINT*”.

When the percentage output to the VFD is less than or equal to the *"EXHAUST OUTPUT FOR FAN STOP"* the Unit Controller will remove the binary signal to the exhaust fan VFD and the motor will stop.

## VFD Exhaust Fan Control BAS

### Overview

A communicated value has been provided to allow for control of the Exhaust Fan via a communicated signal from the Building Automation System. This will allow direct Exhaust Fan Control to be provided by the BAS. This additional control will allow for building pressure control to be maintained by an external source and not controlled directly by the unit. The option of standard building pressure control is still available, as seen in the previous section *Modulating Exhaust with A VFD*.

### Required Programmed Values

*"EXHAUST CONTROL BAS"* must be set to *"USER ENABLED"* in the SERVICE key or enabled through BAS Point EXH\_CTRL\_BAS(BV24).

BAS Point to control Exhaust Fan Speed is EXH\_DAMPER/VFD(AV52).

*"POWER EXHAUST TYPE"* must be set to *"MODULATE DAMPER-VFD"* through the OPTIONS, key EXHAUST subsection of the User Interface.

*"EXHAUST OUTPUT FOR FAN START"* must be set using the SETPOINTS key, EXHAUST subsection of the User Interface.

*"EXHAUST OUTPUT FOR FAN STOP"* must be set using the SETPOINTS key, EXHAUST subsection of the User Interface.

### Operation

When the *"EXHAUST CONTROL BAS"* is set to USER ENABLED and the *"POWER EXHAUST TYPE"* is set to MODULATE DAMPER-VFD, the controller shall read a BACnet BAS Analog Value. This Analog Value shall be set up for 0-100%.

The controller shall read the BACnet Analog Value and drive the *"EXHAUST/RETURN FAN VFD"* to this value. For example, if the Analog Value is 27%, the *"EXHAUST/RETURN FAN VFD"* shall be 27%. The outputs shall follow this Analog Value.

When the Analog Value is more than or equal to the *"EXHAUST OUTPUT FOR FAN START,"* the Unit Controller will send a binary signal to the exhaust fan VFD, and the motor will start. This binary output origi-

ates at terminal 4 of terminal block TB1 of the Unit Controller.

When the Analog Value is less than or equal to the *"EXHAUST OUTPUT FOR FAN STOP,"* the Unit Controller will remove the binary signal to the exhaust fan VFD and the motor will stop.

## RETURN FAN OPERATION

### VFD Return Fan without Exhaust

#### Required Programmed Values

*"POWER EXHAUST TYPE"* must be set to *"RETURN FAN W/O EXH"* through the OPTIONS key, EXHAUST subsection of the User Interface.

#### Operation

The Return Fan is started and stopped with the Supply Fan, if the Supply Fan is ON the Return Fan will also be energized. The speed of the Return Fan will be controlled by the Return Fan Plenum Pressure Control Loop to maintain the Active Return Plenum Pressure setpoint. The Active Return Plenum pressure setpoint will be set to the Minimum Plenum Pressure of 0.05" W.C.

### VFD Return Fan with Exhaust

#### Required Programmed Values

*"POWER EXHAUST TYPE"* must be set to *"RETURN FAN W / EXHAUST"* through the OPTIONS key, EXHAUST subsection of the User Interface.

*"BUILDING PRESSURE SETPOINT"* must be set using the SETPOINTS key, EXHAUST subsection of the User Interface.

*"RETURN PRESSURE HIGH SETP"* must be set using the SETPOINTS key, SUPPLY SYSTEM subsection of the User Interface.

#### Operation

The Return Fan is started and stopped with the Supply Fan, if the Supply Fan is ON the Return Fan will also be energized. The speed of the Return Fan will be controlled by the Return Fan Plenum Pressure Control Loop to maintain the Active Return Plenum Pressure setpoint. The Active Return Plenum Pressure setpoint will vary based on the value of the Exhaust Output. The Exhaust Output value is generated by a proportional control algorithm using the *"BUILDING PRESSURE SETPOINT"* (see *Figure 34 on page 95*).

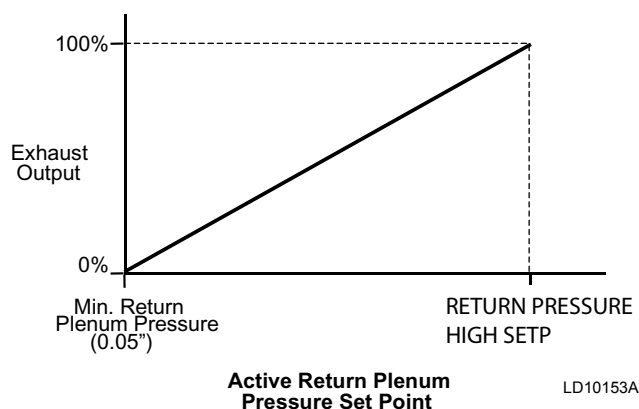

**FIGURE 34 - ACTIVE RETURN PLENUM PRESSURE SETPOINT VS. EXHAUST OUTPUT**

### VFD Return Fan with Exhaust BAS Control

#### Overview

A communicated value has been added to allow for the control of the Modulating Exhaust Damper when using a Return Fan with Exhaust on the Series 100 equipment. This will allow direct Modulated Exhaust Damper control to be provided by the BAS. This additional control will allow for building pressure control to be maintained by an external source and not controlled directly by the unit.

#### Required Program Values

"EXHAUST CONTROL BAS" must be set to "USER ENABLED" in the SERVICE Key or enabled through BAS Point EXH\_CTRL\_BAS(BV24).

BAS Point to control Exhaust Damper Position is EXH\_DAMPER/VFD(AV52)

"POWER EXHAUST TYPE" must be set to "RETURN FAN W/EXHAUST" through the OPTIONS key, EXHAUST subsection of the User Interface.

"BUILDING PRESSURE SETPOINT" must be set using the SETPOINTS key, EXHAUST subsection of the User Interface.

"RETURN PRESSURE HIGH SETP" must be set using the SETPOINTS key, SUPPLY SYSTEM subsection of the User Interface.

#### Operation

When the "EXHAUST CONTROL BAS" is set to "USER ENABLED" and the "POWER EXHAUST TYPE" is set to "RETURN FAN W/EXHAUST," the controller shall read a BACnet BAS Analog Value. This Analog Value shall be set up for 0-100%.

The controller shall read the BACnet Analog Value and drive the "EXHAUST DAMPER" to this value. For example, if the Analog Value is 27%, the "EXHAUST DAMPER" shall be 27%. The outputs shall follow this Analog Value. The Return Fan operations remains unchanged. The speed of the Return Fan is still controlled by the Return Fan Plenum Pressure versus the Return Fan Plenum Pressure Setpoint. For specific Return Fan operation, see *Return Fan Operation on page 94* and its subsections.

### Ventilation System

#### Overview

The Unit Controller can be configured for several different damper and ventilation options. The damper options are:

- None
- 2-Position Damper
- Standard Dampers
- TEK Air Full IAQ

Everything except the NONE and 2-POSITION DAMPER can be configured for:

- Demand Ventilation
- Fixed Minimum

In order for the Ventilation System to be active, the following must occur:

- The unit is in any OCCUPIED Mode.
- There must be a 24-volt output from the Unit Controller to the Supply Fan control circuit. This output is contained at Terminal Block TB1 - Terminal 2.
- There must be a 24-volt input to the Unit Controller from the Supply Fan Air Proving Switch to verify Supply Fan operation 30 seconds after the Supply Fan circuit is energized. This input is contained at Terminal Block TB7 – Terminal 10.
- When the economizer becomes active, the position of the dampers are controlled by the Economizer PI logic and can move the dampers beyond the Active Ventilation Minimum Position; however, the Economizer PI logic can never close the dampers less than the Active Ventilation Minimum Position.

## 2-Position Damper

### Required Program Values

“*DAMPER HARDWARE*” must be set to “*2-POSITION DAMPER*.” This is set through the OPTIONS key, VENTILATION subsection of the User Interface.

“*VENTILATION SYSTEM*” must be set to ENABLED. This is set through the PROGRAM key, VENTILATION subsection of the User Interface.

### Sequence Of Operation

The analog output to the Outdoor damper is 10.0 volts when the Ventilation System Status is active. The analog output to the Outdoor damper is 0.0 volts when the Ventilation System Status is inactive. The amount of outdoor air is set by adjusting the damper linkage

## Demand Ventilation

### Required Program Values

“*VENTILATION CONTROL*” must be set to “*DEMAND*”. This is set through the OPTIONS key, VENTILATION subsection of the User Interface.

“*DAMPER HARDWARE*” must be set to “*STANDARD DAMPERS*”, or “*TEK AIR FULL IAQ*”. This is set through the OPTIONS key, VENTILATION subsection of the User Interface.

“*VENTILATION SYSTEM*” must be set to ENABLED. This is set through the PROGRAM key, VENTILATION subsection of the User Interface.

“*INSIDE-OUTSIDE CO<sub>2</sub> OFFSET*” must be set through the SETPOINTS key, VENTILATION subsection of the User Interface.

On units configured as “*STANDARD DAMPERS*,” the “*OA DAMPER MIN POSITION 1*” and “*OA DAMPER MIN POSITION 2*” must be set through the SETPOINTS key, VENTILATION subsection of the User Interface.

On units configured as “*TEK AIR FULL IAQ*,” the “*MIN FLOW DEMAND VENTILATION*” and “*MAX FLOW DEMAND VENTILATION*” must be set through the SETPOINTS key, VENTILATION subsection of the User Interface.

### Sequence Of Operation

The position of the outdoor air damper is determined by the difference of the CO<sub>2</sub> level in the return air versus the CO<sub>2</sub> level of the outdoor air. When the indoor CO<sub>2</sub> level becomes more than or equal to the outdoor CO<sub>2</sub>

level plus the “*INSIDE-OUTSIDE CO<sub>2</sub> OFFSET*,” the Unit Controller will use a PI algorithm to open the outside air damper from the I or “*MIN FLOW DEMAND VENTILATION*” towards the “*OA DAMPER MIN POSITION 2*” or “*MAX FLOW DEMAND VENTILATION*” setting. The Unit Controller will then modulate the damper to lower the indoor CO<sub>2</sub> level between the minimum and maximum settings.

## Fixed Minimum

### Required Program Values

“*VENTILATION CONTROL*” must be set to “*FIXED MINIMUM*”. This is set through the OPTIONS key, VENTILATION subsection of the User Interface.

“*DAMPER HARDWARE*” must be set to “*STANDARD DAMPERS*”, or “*TEK AIR FULL IAQ*”. This is set through the OPTIONS key, VENTILATION subsection of the User Interface.

“*VENTILATION SYSTEM*” must be set to ENABLED. This is set through the PROGRAM key, VENTILATION subsection of the User Interface.

On units configured as “*TEK AIR FULL IAQ*,” the “*MINIMUM OA FLOW SET POINT*” must be set through the SETPOINTS key, VENTILATION subsection of the User Interface.

On units configured as “*STANDARD DAMPERS*,” the “*OA DAMPER MIN POSITION 1*” and “*OA DAMPER MIN POSITION 2*” must be set through the SETPOINTS key, VENTILATION subsection of the User Interface.

### Sequence Of Operation

On unit with air measuring stations, configured for “*TEK AIR FULL IAQ*,” the damper minimum position is the programmed “*MINIMUM OA FLOW SET POINT*.”

On units configured for “*STANDARD DAMPERS*” and the Unit Type is set to CONSTANT VOLUME, the damper minimum position is the programmed “*OA DAMPER MIN POSITION 1*.”

On units configured for “*STANDARD DAMPERS*” and the Unit Type is set to VARIABLE AIR VOLUME or FLEXSYS, the minimum position will vary between the “*OA DAMPER MIN POSITION 1*” and “*OA DAMPER MIN POSITION 2*” based on the speed of the VFD Supply Fan. As the fan speed decreases, the damper position will increase. *Figure 35 on page 97* indicates how the algorithm shall function:



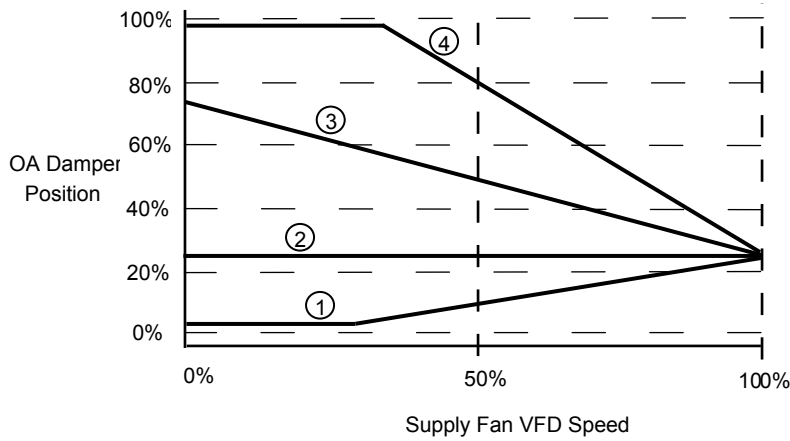

Curve	OA Damper Minimum Position	OA Damper Maximum Position
1	25%	10%
2		25%
3		50%
4		80%

**FIGURE 35 - FIXED MINIMUM VENTILATION CONTROL - OA DAMPER VS. SUPPLY FAN VFD SPEED**

### Tek-Air: Air Measuring Station

#### General

The unit uses two probe assemblies located between the outdoor air intake and the outdoor air damper. There is one on each side. Air moving through the intake impacts the face of the probe and must then flow around it. A high pressure region is created on the forward surface of the probe. As the air flows around it, a low pressure area is created in the wake of the probe. The difference between these two pressures can be related by calculation to the volume of ventilation air being drawn in. The system consists of two probes, a transducer, and a monitor.

#### Required Program Values

“*DAMPER HARDWARE*” must be set to “*TEKAIR FULL IAQ*”. This is set through the **OPTIONS** key, **VENTILATION** subsection of the User Interface.

“*VENTILATION SYSTEM*” must be set to “*ENABLE*”. This is set through the **PROGRAM** key, **VENTILATION** subsection of the User Interface.

“*UNIT INSTALLED ALTITUDE*” is set using the **SETPOINT** key, **VENTILATION** subsection of the User Interface.

#### Factory Set Up

The air measuring station should be set up from the factory. These values can be found under the “**CUSTOM SET-UP**” menu of the TEK Air monitor. In order to view this section you will be required to enter password 1234. The following items and their factory set up values are contained under this menu.

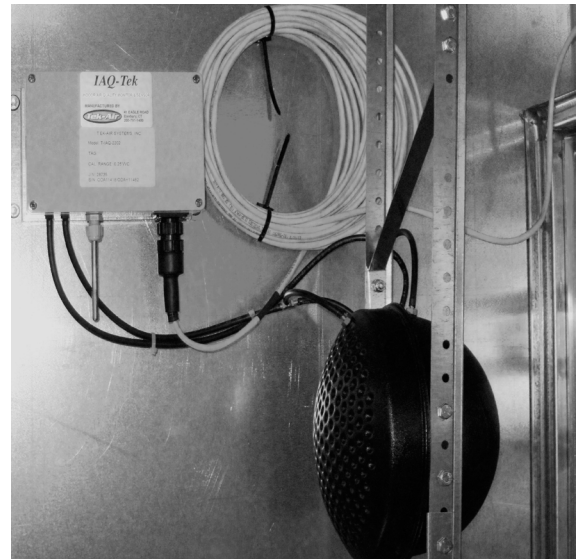

- “AREA OF FLOW DEVICE” – This is the area of flow in square feet. The parameter should be **27.1 ft<sup>2</sup>**.
- “SENSOR FLOW COEFF” – This is the Sensor Flow Coefficient for the type of differential pressure generating device being used. We use an IAQ-TEK probe, which uses a value of **0.762**.
- “ALTITUDE” – This is the altitude in feet above or below sea level for the location of the probe. The Unit Controller makes an altitude correction calculation; therefore, this parameter should always be set to **0 feet**.
- “LOW FLOW ALARM STPT” – This is the low flow alarm set point in CFM. This parameter should be set to **0 CFM**.
- “ANALOG OUT FLOW STPT” – This is the full-scale range in CFM for the analog output scaling. This parameter should be set to **32,000 CFM for 70-80 ton units and 36,000 CFM for 90-105 ton units**.
- “ALARM DELAY PERIOD” – Several of the IAQ-TEK alarm conditions have their initiation inhibited for a delay period. This period is utilized to create a delay between the actual occurrence of the alarm and the reporting of the alarm at the display. This parameter should be set to **20 seconds**.
- “PRESS. AVERAGE INT” – This is the averaging time for the average pressure calculation. The parameter should be set to **10 seconds**.
- “USE FAN INTERLOCK” – The fan interlock is used to interlock the action of the monitor to the running of the fan. When this function is turned ON, the low CFM airflow alarm is deactivated any time the digital input function reports that the fan is OFF. This parameter should be set to **ON**.
- “BALANCERS ADJ FACT” – This feature allows the application of an airflow correction factor based on a difference between the calculated airflow and the air balancers report. Factory Default is **100%**. For Example, if the monitor indicates the flow 1000 CFM and the Balancer indicates the flow is 900 CFM, the BAF is  $1000/900=90\%$ . Factory Default is 100%.
- “PASSWORD CHANGE” – This allows the password to be changed. The password is set to **1234**.
- “AUTO-ZERO INTERVAL” – This parameter should be set to **30 minutes**.
- “ENCL TEMP SET PT” – The transducer has an internal heater to maintain a constant temperature in the transducer enclosure. This value is used in the operation of the heater. The parameter should be set to **120 °F**.
- “OA TEMP SENSOR BIAS” – Allows the air balancer to adjust the monitor outside air temperature readings to those observed by the air balancer. The Unit Controller uses the outside air input from the outdoor air sensor. This parameter should always be set to **0**.
- “TRANSDUCER ZERO” – This sets the monitor zero range in “W.C.” corresponding to the transducer 4mA output. This parameter should be set to **0.00” W.C.**
- “TRANSDUCER FS” – This sets the monitor full scale range in “W.C.” corresponding to the transducer 20mA output. This parameter should be set to **0.25” W.C.**

### **Diagnostic Alarms**

The Diagnostic Alarms are used to provide diagnostic information on the performance of the product, and to alert the user to possible malfunction. Following is a description of the Diagnostic Alarms that are available at the IAQ-TEK monitor.

- **LOW FLOW ALARM** – The Low Flow Alarm is used to alert the building operators that the intake volume has fallen below the minimum acceptable level. The control compares the derived CFM value to the programmed “LOW FLOW ALARM” set point. The unit is shipped from the factory with a “LOW FLOW ALARM” set point of 0 CFM. Should the airflow remain below this value for longer than the programmed “ALARM DELAY PERIOD, 20 seconds, the IAQ-TEK monitor will show a Low Flow Alarm. To reset to normal the air volume must rise to a value that is 10% high then the “LOW FLOW ALARM” set point. Once this threshold has been crossed, the alarm is reset automatically.
- **REVERSE FLOW ALARM** – This is used to identify that the airflow is blowing out of the intake of the outdoor air. Should the airflow remain reversed for longer than the programmed “ALARM

DELAY PERIOD, 20 seconds, the IAQ-TEK monitor will show a Reverse Flow Alarm. In order reset, the pressure input from the probe to the transducer must increase to zero or have a sign change to positive. Once the value has changed, the alarm is reset automatically.

- **PRESSURE LOSS ALARM** – The signal from the pressure transducer to the monitor indicates a negative pressure. The alarm will be initiated immediately without a delay period.
- **OUTDOOR AIR TEMPERATURE SENSOR LOSS ALARM** – Indicates the OA Temp Input to the monitor went either high (input short) or low (input open). The alarm will be initiated immediately without a delay period.
- **ENCLOSURE TEMPERATURE LOSS** – Indicates the enclosure temperature input to the monitor from the transducer went high (input short) or low (input open). The alarm will be initiated immediately without a delay period.
- **LOSS OF ENCLOSURE HEATER** – Indicates the enclosure temperature fell 11.0 °F below the “ENCL TEMP SET PT”. Should this remain low for longer than the programmed “ALARM DELAY PERIOD, 20 seconds, the IAQ-TEK monitor will show a Loss of Enclosure Heater Alarm. If the temperature remains below for 1 hour, a heater malfunction will be initiated.
- **AUTO-ZERO VALVE MALFUNCTION** – Indicates the pressure transducer’s auto-zero valve malfunction. The alarm will be initiated immediately without a delay period.
- **MEMORY LOSS ALARM** – Indicates there has been a loss of nonvolatile memory parameters. The alarm will be initiated immediately without a delay period.
- **CHECKSUM ERROR ALARM** – Indicates there is a memory checksum error. The alarm will be initiated immediately without a delay period.

## TEK Air Full IAQ

### Sequence Of Operation

When Ventilation Status is ACTIVE, damper output #1 shall be controlled per the Flow Control PI Output. *Figure 36 on page 99* details the relationship of the Damper Output voltage vs. the Flow Control PI Output.

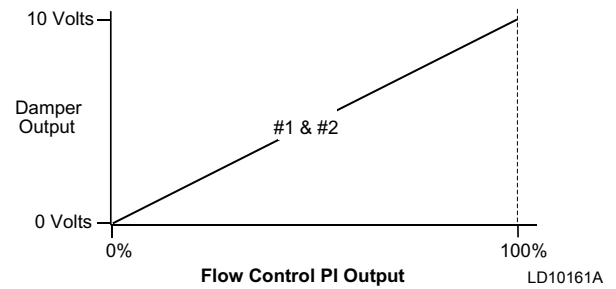

**FIGURE 36 - EK AIR FULL IAQ FLOW CONTROL**

When OA conditions are suitable for economizing Damper Output #1 shall be controlled per the Flow Control PI Output. *Figure 37 on page 99* details the relationship of the OA Damper voltage vs. the Economizer PI Output.

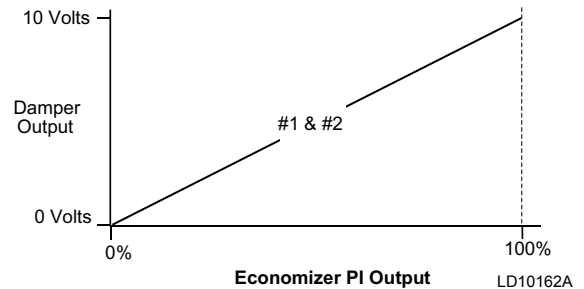

**FIGURE 37 - TEK AIR FULL IAQ ECONOMIZER**

### Air Measurement Station Auto Zero

The Unit Controller will conduct a Auto Zero process every 10 hours provided the following criteria have been met:

- The unit has a TEK Air Full IAQ station installed.
- The BI output to the Supply Fan is OFF for 10 minutes.
- 10 hours have elapsed since the last auto-zero attempt.

or

- Unit operating state is STOP format for at least 10 minutes.

### Air Measurement Station Field Adjustment

Because the Unit Controller takes into account elevation and temperature in making the airflow calculation the calculated airflow value is very accurate; however, in some instances, the value measured by the air balancer may not match the value shown in the User Interface. The correction factor can be programmed into the Unit Controller through the SETPOINTS key

VENTILATION subsection “*AMS FACTOR 1*”. Divide the airflow value measured by the air balancer by the airflow value shown in the User Interface. Enter this value as “*AMS FACTOR 1*”.

### TEK Air Full IAQ Air Measurement Station

A “*WRN - OA FLOW PRS 1*” will be displayed in the HISTORY buffer and a “*SENSOR/MSR WARNING*” will be posted under the STATUS key of the Unit Controller if the “*OA FLOW INPUT 1*” is less than 700 counts for 300 seconds.

### SMOKE PURGE

The following parameters must be programmed into the Unit Controller:

- “*SMOKE PURGE SEQ 1*” can be set to “*PURGE,*” “*PRESSURIZATION,*” or “*EVACUATION*” through the OPTIONS key, UNIT DATA subsection of the User Interface.
- “*SMOKE PURGE SEQ 2*” can be set to “*PURGE,*” “*PRESSURIZATION,*” or “*EVACUATION*” through the OPTIONS key, UNIT DATA subsection of the User Interface.
- “*SMOKE PURGE SEQ 3*” can be set to “*PURGE,*” “*PRESSURIZATION,*” or “*EVACUATION*” through the OPTIONS key, UNIT DATA subsection of the User Interface.

Whenever a Smoke Purge sequence is started, all normal heating and cooling functions are stopped, regardless of control inputs. This will occur within 2 seconds after the Smoke Purge signal is received.

On VAV units duct static pressure control is maintained during smoke purge operation.

“*SMOKE PURGE SEQ 1,*” “*SMOKE PURGE SEQ 2,*” and “*SMOKE PURGE SEQ 3*” are initiated through a digital input to the Unit Controller. The input for “*SMOKE PURGE SEQ 1*” is at terminal block TB8 – Terminal 4. The input for “*SMOKE PURGE SEQ 2*” is at terminal block TB8 – Terminal 5. The input for “*SMOKE PURGE SEQ 3*” is at terminal block TB8 – Terminal 7.

“*SMOKE PURGE SEQ 1*” will have the highest priority, “*SMOKE PURGE SEQ 2*” will have medium priority, and “*SMOKE PURGE SEQ 3*” will have the lowest priority.

“*PURGE*” – purge shall be used to displace the air inside the space with fresh outside air. When this sequence is started the following will occur:

- Start the Supply Fan, if not already ON.
- Start the Return Fan, if not already ON.
- Start the Exhaust Fan, if not already ON.
- Set all Outside Air Damper Output(s) to 100%.
- Set the Return Air Damper to 0%.
- Set the Exhaust Damper Output to 100%.

“*PRESSURIZATION*” – Purge shall be used to pressurize the building or space in order to force the air inside the space through the walls to adjacent spaces or outside the building envelope. When this sequence is started the following will occur:

- Start the Supply Fan, if not already ON.
- Start the Return Fan, if not already ON.
- Stop the Exhaust Fan if ON.
- Set all Outside Air Damper Output(s) to 100%.
- Set the Return Air Damper to 0%.

“*EVACUATION*” – Purge shall be used to evacuate (negatively pressurize) the building or space in order to draw air through the walls from adjacent spaces or outside the building envelope. When this sequence is started the following will occur:

- Stop the Supply Fan if ON.
- Start the Return Fan, if not already ON.
- Start the Exhaust Fan, if not already ON.
- Set all Outside Air Damper Output(s) to 0%.
- Set all Return Air Dampers to 100%.
- Set the Exhaust Damper Output to 100%.

## SECTION 6 – USER INTERFACE CONTROL CENTER

### USER INTERFACE CONTROL CENTER

The User Interface is used to commission, monitor, and troubleshoot the rooftop unit. It provides access to operational data, parameter programming, and access to past “history” information that was recorded at the time of a unit or system fault.

The User Interface is installed in the low voltage control compartment of the rooftop unit.

The User Interface uses a flexible membrane style keypad and has an 80-character (2 lines of 40 characters) liquid crystal display. The display has a lighted background for night viewing and can be viewed in direct sunlight. The backlighting will energize when any button is pressed.

The keypad allows complete control of the system from a central location. The keypad offers a multitude of commands available to access displays, program pa-

rameters, and initiate system commands. The keypad consists of 36 keys, that are divided into three categories: Data Entry, Navigation, and Menu Selection keys. A description of each of the keys is contained below.

### Data Entry Keys

The Data Entry keys provide a means to enter values for items that support edits. The keys available to support numeric input are the 0 through 9 keys, the decimal key, the +/- key, the **X** key and the **✓** key. The keys available to support choice input are the **◀** key, the **▶** key, the **X** key, and the **✓** key. Editing is started by pressing the **✓** key. **Once editing has started, the user must press either the **✓** key or the **X** key.** Any other key press will result in the “Press **✓** or **X** to Exit” message displayed for two seconds. If you try to edit an item that is view only it will be ignored by the menu system.

6

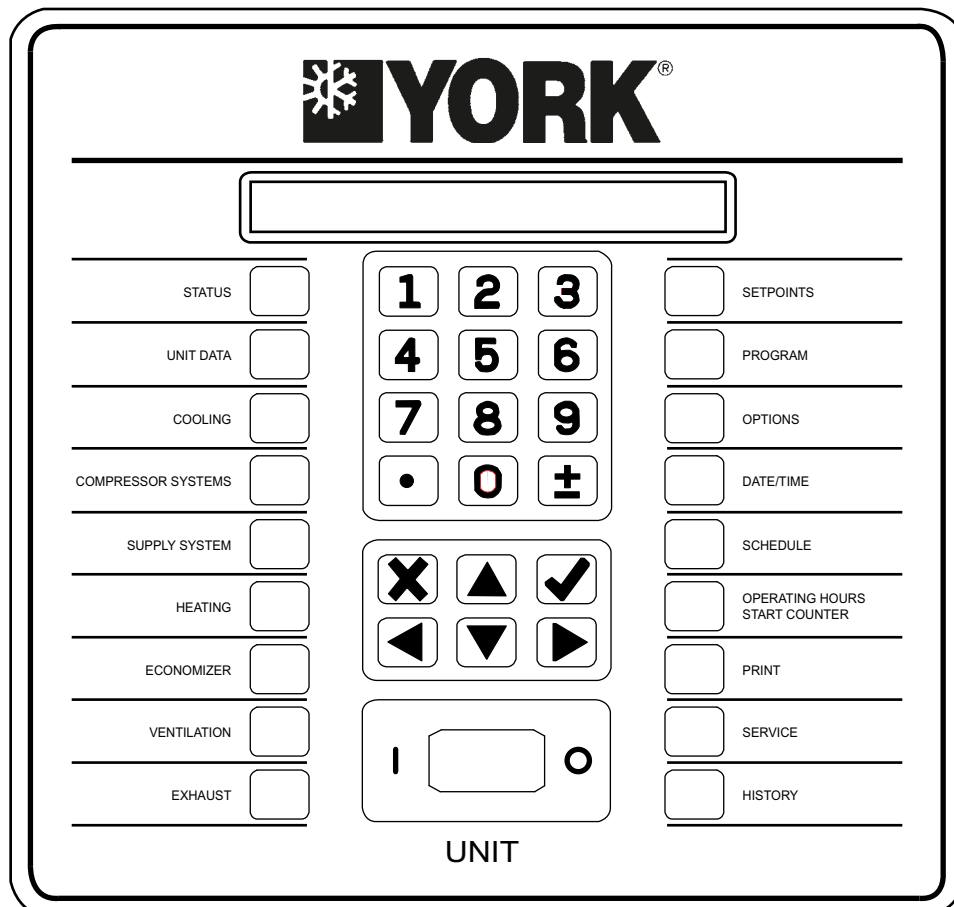

FIGURE 38 - USER INTERFACE CONTROL PANEL

LD010669

When a numeric value that can be modified is displayed, the Default, High, and Low prompt will be shown in the upper right portion of the display. The cursor will be shown at the digit to be changed. The cursor will be shown after editing has started. After the desired numeric value has been entered, press the ✓ key to save the new value and exit the edit mode. Pressing the ◀ key will fill in the default value. Edits will only be accepted when followed by pressing the ✓ key. Pressing the ✕ key while in the edit mode will cancel the edit mode and leave the value unchanged. If an out of range value is entered, the Default, High and Low prompt is replaced by the “Out of Range” message for two seconds.

When a choice value that can be modified is displayed, the ◀ ▶ prompt will be shown in the upper right portion of the display. The cursor will be shown after editing has been started. The ◀ key or the ▶ key will allow the different choices to be viewed. When the desired choice is displayed, press the ✓ key to save the new value and exit the edit mode. Pressing the ✕ key while in the edit mode will cancel the edit mode and leave the value unchanged.

### Navigation Keys

The Navigation keys provide a means to browse items within a menu. The keys currently available to support navigation are the Menu Select keys, the ▲ key, the ▼ key, the ◀ key, and the ▶ key.

Pressing a Menu Select key brings the user to the first screen under that menu. The screens within each menu are arranged in a circular list. The user may browse through the screens using the ▲ key and the ▼ key. Pressing the ▼ key will advance through the screens in order from top to bottom until the bottom screen has been reached. When the bottom screen is displayed, pressing the ▼ key will wrap the display to the top screen of the menu. Pressing the ▲ key will move through the screens in order from bottom to top until the top screen has been reached. When top screen is displayed, pressing the ▲ key will wrap the display to the bottom screen of the menu. Once either the ▲ key or the key ▼ is pressed, pressing any Menu Select key will bring the user to the first screen under that menu (even if it is the same menu being viewed).

Navigation through the circular list of items can also be achieved by repeated presses of the same Menu Select key, as long as no other keys are pressed. For example,

pressing the UNIT DATA key three times will bring the user to the third screen of the UNIT DATA menu; pressing the UNIT DATA key once, then pressing the ▼ key, then pressing the UNIT DATA key again will bring the user to the first screen of the UNIT DATA menu.

The ◀ key and the ▶ key are used to scroll “side-ways” between the same displays for each system. For example, when viewing the Sys 1 Pressures under the COMPRESSOR SYSTEMS key, pressing the ▶ key will scroll “sideways” to the Sys 2 Pressures display and pressing the ◀ key will scroll “sideways” to the Sys Pressures display for the last system on the unit.

When programming numeric or non-numeric values, the ▼ key and the ▲ key are used to scroll forward (down) and backward (up) through the items to be programmed or set.

### Menu Select Keys

The following menu keys are available on the User Interface: STATUS, UNIT DATA, COOLING, COMPRESSOR SYSTEMS (1, 2, or 3), SUPPLY SYSTEM, HEATING, ECONOMIZER, VENTILATION, EXHAUST, SETPOINTS, PROGRAM, OPTIONS, DATE/TIME, SCHEDULE, OPERATING HOURS / START COUNTER, PRINT, SERVICE, and HISTORY.

Each of the above menu keys gives access to a list of specific items contained in that menu. To minimize clutter, only the items applicable to the current unit configuration will be displayed. Pressing any of the menu select keys at any time will send the user to the first item of the associated menu, provided the user is not editing an item in the current menu key item or the menu key is being used to navigate through a list of items.

*Table 26 on page 103 through Table 34 on page 114 list the information that is contained under the STATUS, UNIT DATA, COOLING, COMPRESSOR SYSTEMS (1, 2, or 3), SUPPLY SYSTEM, HEATING, ECONOMIZER, VENTILATION, and EXHAUST menu selection keys of the User Interface. The tables contain the Displayed Text, Pass Word Level (if applicable), Range of Values (if applicable), Default Value (if applicable), what key (SETPOINTS, PROGRAM, OPTIONS) to use to change the value (if applicable), and under what circumstances the item is displayed.*

**TABLE 26 - STATUS**

DISPLAY TEXT	RANGE	DEFAULT	SETTING LOCATION	SHOWN WHEN
<b>UNIT - OVERALL STATUS</b>	Local Stop / Run / Unit Trip / Unit Fault / Unit Lockout / SMK Purge #-Press / SMK Purge #-Purge / SMK Purge #-Evac	Derived		Always
<b>CURRENT OPER MODE</b>	OCC Standby / OCC Cooling Low / OCC Cooling High / OCC Heating Low / OCC Heating High / UNOCC Standby / UNOCC Cooling Low / UNOCC Cooling High / UNOCC Heating Low / UNOCC Heating High / Morning Warm-Up / Comfort Vent Cooling / Comfort Vent Heating	Derived		Unit Type Equals CV
<b>CURRENT OPER MODE</b>	Occupied Standby / Occupied Heating / Occupied Cooling / Unoccupied Standby / Unoccupied Heating / Unoccupied Cooling / Morning Warm-Up	Derived		Unit Type Equals VAV
<b>CURRENT OPER MODE</b>	Occupied Standby / Occupied Heating / OCC Cooling W/O Byp / OCC Cooling W/ Byp / Unoccupied Standby / Under Floor Temp Override	Derived		Unit Type Equals FLEXSYS
<b>SUPPLY SYS STATUS</b>	Normal - Active / Normal Inactive / Safety Trip / Safety Fault / Safety Lockout	Derived		Always
<b>COMP SYS 1 STATUS</b>	Normal - Comp A On / Normal - Comp B On / Normal - Both On / Normal - Both Off / Safety Trip / Safety Fault / Safety Lockout / Low Amb Inhibit / Low Suct Temp Unl / High Dp Unload / User Disabled	Derived		Always
<b>COMP SYS 2 STATUS</b>	Normal - Comp A On / Normal - Comp B On / Normal - Both On / Normal - Both Off / Safety Trip / Safety Fault / Safety Lockout / Low Amb Inhibit / Low Suct Temp Unl / High Dp Unload / User Disabled	Derived		Always
<b>COMP SYS 3 STATUS</b>	Normal - Comp A On / Normal - Comp B On / Normal - Both On / Normal - Both Off / Safety Trip / Safety Fault / Safety Lockout / Low Amb Inhibit / Low Suct Temp Unl / High Dp Unload / User Disabled	Derived		Always
<b>HEATING SYS STATUS</b>	Normal - Active / Normal - Inactive / Safety Trip / Safety Fault / Safety Lockout / User Disabled / None	Derived		Always
<b>ECONO SYS STATUS</b>	Normal - Active / Normal - Inactive / Safety Trip / Safety Fault / Safety Lockout / User Disabled / None	Derived		Always
<b>VENT SYS STATUS</b>	Normal - Active / Normal - Inactive / Safety Trip / Safety Fault / Safety Lockout / User Disabled / None	Derived		Always
<b>EXHAUST SYS STATUS</b>	Normal - Active / Normal - Inactive / Safety Trip / Safety Fault / Safety Lockout / User Disabled / None	Derived		Always
<b>SENSOR / MISC STATUS</b>	Normal / Warning / Safety Trip / Safety Fault / Safety Lockout	Derived		Always
<b>FILTER STATUS</b>	Okay / Change	Derived		Always

**6**

TABLE 27 - UNIT DATA

DISPLAY TEXT	PASS WORD LEVEL	RANGE	DEFAULT	SETTING LOCATION	SHOW WHEN UNIT TYPE IS:
UNIT TYPE	2	Constant Volume / Variable Air Volume / Flexsys / Single Zone VAV	Constant Volume	Options / Unit Data	Always
UNIT SIZE	2	70 Ton, 75 Ton, 80 Ton, 85 Ton, 90 Ton, 95 Ton, 105 Ton	50 Ton	Options / Unit Data	Always
REFRIGERANT TYPE	2	R22 / R407c / R410a	R-22	Options / Unit Data	Always
CONTROL METHOD	1	Staged / Wired Zone Temp / Comm Zone Temp	Staged	Options / Unit Data	Unit Type Equals Constant Volume
SAT RESET METHOD	1	Hardwired, Outside Air, Return Air, Supply Fan Speed	Hardwired Input	Options / Unit Data	Unit Type Equals Variable Air Volum
<b>SUPPLY AIR TEMP</b>					
CURRENT		-20.0 °F To 180.0 °F	Look Up Table		Unit Type E Equals Constant Volume Or Variable Air Volum
ACTIVE SP		50.0 °F To 150.0 °F	Derived		
<b>MX SUPPLY AIR TEMP</b>					
CURRENT		-20.0 °F To 180.0 °F	Look Up Table		Unit Type E Equals Flexsys
SETPOINT	1	50.0 °F To 65.0 °F	65.0 °F	Setoints/ Unit Data	
<b>ZONE TEMP*</b>					
CURRENT		-20.0 °F To 180.0 °F	Look Up Table		Unit Type Equals Constant Volume Or Variable Air Volum
OCC ZONE COOLING SETPOINT	1	OCC Zone Heating Setpoint + 2.0 °F	72.0 °F	Setoints/ Unit Data	
<b>ZONE TEMP*</b>					
CURRENT		-20.0 °F To 180.0 °F	Look Up Table		Unit Type Equals Constant Volume Or Variable Air Volum
UNOCC ZONE COOLING SETPOINT	1	UNOCC Zone Heating Setpoint + 2.0 °F To 95.0 °F	85.0 °F	Setoints/ Unit Data	
<b>ZONE TEMP*</b>					
CURRENT		-20.0 °F To 180.0 °F	Look Up Table		Unit Type Equals Constant Volume Or Variable Air Volum
OCC ZONE HEATING SETPOINT	1	60 °F To OCC Zone Cooling Setpoint - 2.0 °F	68.0 °F	Setoints/ Unit Data	
<b>ZONE TEMP*</b>					
CURRENT		-20.0 °F To 180.0 °F	Look Up Table		Unit Type Equals Constant Volume Or Variable Air Volum
UNOCC ZONE HEATING SETPOINT	1	50 °F To UNOCC Zone Cooling Setpoint - 2.0 °F	60.0 °F	Setoints/ Unit Data	
SMOKE PURGE SEQ 1	1	Purge / Pressurization / Evacuation	Purge	Options / Unit Data	Always
SMOKE PURGE SEQ 2	1	Purge / Pressurization / Evacuation	Pressurization	Options / Unit Data	Always
SMOKE PURGE SEQ 3	1	Purge / Pressurization / Evacuation	Evacuation	Options / Unit Data	Always
DISPLAY LANGUAGE	1	English / Spanish	English	Options / Unit Data	Always
DISPLAY UNITS	1	Imperial / Metric	Imperial		Always

\* Only the zone temp screen for the current active mode will be shown.



**TABLE 28 - COOLING**

DISPLAY TEXT	PASS WORD LEVEL	RANGE	DEFAULT	SETTING LOCATION	SHOW WHEN UNIT TYPE IS
<b>SUPPLY AIR TEMP</b>					
CURRENT		-20.0 °F To 180.0 °F	Look Up Table		Unit Type Equals Constant
ACTIVE SP		50.0 °F To 150.0 °F	Derived		Volume Or Variable Air Volum
<b>FLEX EVAP TEMP</b>					
CURRENT		-20.0 °F To 180.0 °F	Look Up Table		Unit Type Equals FLEXSYS
ACTIVE SP		50.0 °F To 60.0 °F	Derived		And Current Oper Mode Is OCC Cooling w/ byp
<b>MX SUPPLY AIR TEMP</b>					
CURRENT		-20.0 °F To 180.0 °F	Look Up Table		Unit Type Equals FLEXSYS
SETPOINT	1	50.0 °F To 75.0 °F	65.0 °F	Setpoints/ Cooling	
COOLING CONTROL OFFSET		1.0 °F To 100.0 °F	Derived		
RETURN AIR DIFF SP	2	2.0 °F To 10.0 °F	6.0 °F	Setpoints/ Cooling	Unit Type Equals FLEXSYS
<b>ZONE TEMP*</b>					
CURRENT		-20.0 °F To 180.0 °F	Look Up Table		Unit Type Equals Constant Volume Or Variable Air Volum
OCC ZONE COOLING SETPOINT	1	OCC Zone Heating + 2.0 °F To 85.0 °F	72.0 °F	Setpoints/ Cooling	
<b>ZONE TEMP*</b>					
CURRENT		-20.0 °F To 180.0 °F	Look Up Table		Unit Type Equals Constant Volume Or Variable Air Volum
UNOCC ZONE COOLING SETPOINT	1	UNOCC Zone Heating + 2.0 °F To 95.0 °F	85.0 °F	Setpoints/ Cooling	
<b>RETURN AIR TEMP</b>					
CURRENT		-20.0 °F To 180.0 °F	Look Up Table		Unit Type Equals Variable Air Volum Or FLEXSYS
RAT COOLING SETPOINT	1	RAT Heating Setp +2.0 °F To RAT For High Sat	70.0 °F	Setpoints/ Cooling	
<b>RETURN AIR BYPASS</b>					
CURRENT		0 to 100%	Derived		Unit type equals FLEXSYS
ACTIVE SP		0 to 100%	Derived		
BYPASS DAMPER POSITION		0 to 100%	Derived		Unit type equals FLEXSYS
<b>UNDERFLOOR AIR</b>					
TEMP		-20.0 °F To 180.0 °F	Look Up Table		Unit type equals FLEXSYS and dewpoint reset equals enabled
HUMIDITY		0 to 100%	Derived		
<b>UNDERFLOOR SLAB</b>					
TEMP		-20.0 °F To 180.0 °F	Look Up Table		Unit type equals FLEXSYS and dewpoint reset equals enabled
DEW POINT		30.0 °F To 100.0 °F	Derived		
MAXIMUM BYPASS	1	20.0 to 40.0%	40%	Setpoints/ Cooling	Unit type equals FLEXSYS
DEW POINT RESET	1	User Enabled User Disabled	User Disabled	Program/ Cooling	Unit type equals FLEXSYS
UNDER FLR TEMP OVRD	1	Active - Inactive	Derived		Unit type equals FLEXSYS

**TABLE 28 – COOLING (CONT'D)**

DISPLAY TEXT	PASS WORD LEVEL	RANGE	DEFAULT	SETTING LOCATION	SHOW WHEN UNIT TYPE IS
<b>ACTIVE SLAB CONTROL</b>	1	User Enabled User Disabled	User Disabled	Program/ Cooling	Unit Type Equals FLEXSYS
<b>1ST STAGE COOLING SETPOINT</b>	1	55.0 °F To 60.0 °F	60.0 °F	Setpoints/ Cooling	Unit Type Equals Constant Volume
<b>2ND STAGE COOLING SETPOINT</b>	1	55.0 °F To 60.0 °F	55.0 °F	Setpoints/ Cooling	Unit Type Equals Constant Volume
<b>SAT LOW SETPOINT</b>	1	55.0 °F To 60.0 °F	55.0 °F	Setpoints/ Cooling	Unit Type Equals Variable Air Volum
<b>SAT HIGH SETPOINT</b>	1	55.0 °F To 60.0 °F	65.0 °F	Setpoints/ Cooling	Unit Type Equals Variable Air Volum
<b>OAT SETPOINT FOR</b>					
<b>LOW SAT</b>	1	OAT Setpoint For High Sat To 90.0 °F	80.0 °F	Setpoints/ Cooling	Unit Type Equals Variable Air Volum And Sat Reset Method Equals Outside Temp
<b>HIGH SAT</b>	1	60.0 °F To OAT Setpoint For Low Sat	70.0 °F	Setpoints/ Cooling	Unit Type Equals Variable Air Volum And Sat Reset Method Equals Outside Temp
<b>RAT SETPOINT FOR</b>					
<b>LOW SAT</b>	1	RAT Setpoint For High RAT +5.0 °F To 90.0 °F	90.0 °F	Setpoints/ Cooling	Unit Type Equals Variable Air Volum And Sat Reset Method Equals Return Temp
<b>HIGH SAT</b>	1	RAT Cooling Setpoint To RAT Setpoint For Low Sat -5.0 °F	80.0 °F	Setpoints/ Cooling	Unit Type Equals Variable Air Volum And Sat Reset Method Equals Return Temp
<b>FAN SPEED SETP FOR</b>					
<b>LOW SAT</b>	1	Fan Speed Setp For High Sat To 100%	90%	Setpoints/ Cooling	Unit Type Equals Variable Air Volum And Sat Reset Method Equals Supply Fan Speed
<b>HIGH SAT</b>	1	50% To Fan Speed Setp For Low Sat	70%	Setpoints/ Cooling	Unit Type Equals Variable Air Volum And Sat Reset Method Equals Supply Fan Speed
<b>EVAP LEAVING AIR TEMP HIGH</b>	1	50.0 °F To 60.0 °F	60.0 °F	Setpoints/ Cooling	Unit Type Equals FLEXSYS
<b>EVAP LEAVING AIR TEMP LOW</b>	1	50.0 °F To 60.0 °F	50.0 °F	Setpoints/ Cooling	Unit Type Equals FLEXSYS
<b>RESET ENTHALPY SP</b>	2	25 To 35 BTU	30 Btu/#	Setpoints/ Cooling	Unit Type Equals FLEXSYS
<b>SUP AIR TEMPERING</b>	2	User Enabled User Disabled	User Disable	Program/ Cooling	Unit Type Equals Variable Air Volum Or FLEXSYS
<b>MECH CLG LOCKOUT TEMP</b>	1	0.0 °F To 65.0 °F	50.0 °F	Setpoints/ Cooling	Press Trans Pkg And Low Ambient Pkg Other Than None
<b>MECH CLG LOCKOUT TMP MINIMUM</b>	2	-10.0 °F To 0.0 °F	0.0 °F	Setpoints/ Cooling	Press Trans Pkg And Low Ambient Pkg Other Than None

\* Only the zone temp screen for the current active mode will be shown.

**TABLE 29 - COMPRESSOR SYSTEMS (1, 2, OR 3)**

DISPLAY TEXT	PASS WORD LEVEL	RANGE	DEFAULT	SETTING LOCATION	SHOW WHEN UNIT TYPE IS
<b>COMP SYS* STATUS</b>		Normal - Comp A On / Normal - Comp B On / Normal - Both On / Normal - Both Off / Safety Trip / Safety Fault / Safety Lockout / Low Amb Inhibit / Low Suct Temp Unl / High Dp Unload / User Disabled	Derived		Always
<b>COMP SYS* STATE</b>	1	Stop / Run / Lockout / Auto Reset	Derived	Options / Comp Sys	Always
<b>CONDENSER FAN 1A / 1</b>		Off / On	Derived		
<b>CONDENSER FAN 1B / 2</b>		Off / On	Derived		
<b>CONDENSER FAN 2A / 3</b>		Off / On	Derived		
<b>CONDENSER FAN 2B / 4</b>		Off / On	Derived		
<b>CONDENSER FAN 3A / 5</b>		Off / On	Derived		Always
<b>CONDENSER FAN 3B / 6</b>		Off / On	Derived		Always
<b>SAFETY INPUT</b>					
<b>LPCO</b>		Okay - Faulted	Derived		Always
<b>CHAIN</b>		Okay - Faulted	Derived		
<b>SUCTION TEMP</b>		-20.0 °F To 180.0 °F	Look Up Table		Press Trans Pkg Indicates That Transducers Are Not Installed For The Applicable System
<b>PRESSURE</b>					
<b>DISCHARGE *</b>		- 0 To 320 PSIG	Look Up Table		Press Trans Pkg Indicates That Transducers Are Installed For The Applicable System
<b>SUCTION *</b>		0 To 800 PSIG	Look Up Table		
<b>TEMPERATURE</b>					
<b>SUCTION</b>	1	-20.0 °F To 180.0 °F	Look Up Table		Press Trans Pkg Indicates That Transducers Are Installed For The Applicable System
<b>SUPERHEAT</b>		0.0 °F To 50.0 °F	Derived		
<b>CURRENT RUN TIME</b>					
<b>COMP A</b>		HH:MM:SS	Derived		Always
<b>COMP B</b>		HH:MM:SS	Derived		
<b>PUMPDOWN</b>	2	User Enabled User Disabled	Disabled	Program/ Comp Sys.	Always
<b>READY TO RUN</b>					
<b>COMP A</b>		Yes - No	Derived		Always
<b>COMP B</b>		Yes - No	Derived		
<b>READY TO STOP</b>					
<b>COMP A</b>		Yes - No	Derived		Always
<b>COMP B</b>		Yes - No	Derived		
<b>SYSTEM UNLOADING PRESSURE</b>	2	250 - 450 PSIG	400 PSIG	Setpoints/ Comp Sys	Press Trans Pkg Does Not Equal None
<b>PRESS TRANS PKG</b>	2	None / Sys 1 / Sys 1, 2 / Sys 1, 2, 3	None	Optional/ Comp Sys	Always
<b>LOW AMBIENT PKG</b>	2	None / Sys 1 / Sys 1, 2 / Sys 1, 2, 3	None	Optional/ Comp Sys	Always

\* May be 1, 2, or 3

**TABLE 30 - SUPPLY SYSTEM**

DISPLAY TEXT	PASS WORD LEVEL	RANGE	DEFAULT	SETTING LOCATION	SHOW WHEN UNIT TYPE IS
SUPPLY SYS STATUS		Normal - Active Normal - Inactive Safety Trip Safety Fault Safety Lockout			Always
<b>SUPPLY FAN</b>					
OUTPUT		On - Off	Derived		Always
STATUS		Running Stopped	Derived		
SUPPLY FAN VFD SPEED		0.0 To 100%	Derived		Unit Type Equals Variable Air Volum Or FLEXSYS
SINGLE ZONE VAV MIN VFD SPEED		33 To 66%	50%		Unit Type equals Single Zone VAV
<b>DUCT STATIC PRESS</b>					
CURRENT		0.00 To 5.00" W.C.	Look Up Table		Unit Type Equals Variable Air Volum Or FLEXSYS
ACTIVE SP		0.00 To 5.00" W.C.	Derived		
<b>RETURN FAN</b>					
OUTPUT		On - Off	Derived		Power Exhaust Type Equals Return W/Exhaust + Return W/O Exhaust Fans
STATUS		Running Stopped	Derived		
EXHAUST / RETURN FAN VFD		0.0 To 100%	Derived		Power Exhaust Type Equals Return W/Exhaust + Return W/O Exhaust Fans
<b>RETURN FAN PRESS</b>					
CURRENT		-1.00 To +1.00" W.C.	Look Up Table		Power Exhaust Type Equals Return W/Exhaust + Return W/O Exhaust Fans
ACTIVE SP		0.00 To +1.00" W.C.	Derived		
DUCT PRESS TRANSDUCER SPAN	2	1.25, 2.5, 5.0	5.0	Setpoints / Supply System	Unit Type Equals Variable Air Volum Or FLEXSYS
DUCT STATIC RESET LOW SETP	1	0 - 1 In-Wg - Span 0 In-Wg To Duct Static Reset High	1.5 In-Wg	Setpoints / Supply System	Unit Type Equals Variable Air Volum Or FLEXSYS
DUCT STATIC RESET HIGH SETP	1	Duct Static Reset Low Limit To Span	2.5 In-Wg	Setpoints / Supply System	Unit Type Equals Variable Air Volum Or FLEXSYS
DUCT STATIC OVER PRESSURE	2	0 - 1 In-Wg - 5 In-Wg	3.0 In-Wg	Setpoints / Supply System	Unit Type Equals Variable Air Volum Or FLEXSYS
RETURN PRESSURE HIGH SETP	2	0.15 To 0.45	0.15	Setpoints / Supply System	Power Exhaust Equals Return W/Exhaust

**TABLE 31 - HEATING**

DISPLAY TEXT	PASS WORD LEVEL	RANGE	DEFAULT	SETTING LOCATION	SHOW WHEN UNIT TYPE IS
HEATING SYS STATUS		Normal - Active / Normal - Inactive / Faulted / User Disabled / Under Floor Control / None	Derived		Always
HEATING SYSTEM TYPE	2	None / Electric/ Staged Gas/ Modulating Gas/ Hot Water/ Steam	None	Options / Heating	Always
GAS HEAT CAPACITY	2	375 Mbh / 750 Mbh / 1125 Mbh	375 Mbh	Options / Heating	Heat Type Equals Staged Gas Or Modulating Gas
ELEC HEAT CAPACITY	2	40 Kw - 200V 40 Kw / 80 Kw / 80 Kw - 200V/ 100 Kw - 200V/ 100 Kw / 120 Kw/ 160 Kw / 200 Kw / 240 Kw	40 Kw	Options / Heating	Heat Type Equals Electric
<b>SUPPLY AIR TEMP</b>					
CURRENT		-20.0 °F To 180.0 °F	Look Up Table		Heat Type Does Not Equal None
ACTIVE SP		50.0 °F To 120.0 °F	Derived		
<b>ZONE TEMP*</b>					
CURRENT		-20.0 °F To 180.0 °F	Look Up Table		Always
OCC ZONE HEATING SETPOINT	1	60.0 °F To Occ Zone Cooling Setpoint -2.0 °F	68.0 °F	Setpoints / Heating	
<b>ZONE TEMP*</b>					
CURRENT		-20.0 °F To 180.0 °F	Look Up Table		Always
UNOCC ZONE HEATING SETPOINT	1	50.0 °F To Unocc Zone Cooling Setpoint -2.0 °F	60.0 °F	Setpoints / Heating	
<b>RETURN AIR TEMP</b>					
CURRENT		-20.0 °F To 180.0 °F	Look Up Table		Heat Type Does Not Equal None And Unit Equals Variable Air Volum Or FLEXSYS
RAT HEATING SETPOINT	1	55.0 °F - Rat Cooling Setpoint -2.0 °F	68.0 °F	Setpoints / Heating	
HEAT ENTERING TEMP		-20.0 °F To 180.0 °F	Look Up Table		Heat Type Equals Staged Gas
<b>STAGED HEAT STATUS</b>					
STGS ON		0 To 6	Derived		Heat Type Equals Electric Or Staged Gas
STGS AVAL		2 To 6	Derived		

**6**

**TABLE 31 – HEATING (CONT'D)**

DISPLAY TEXT	PASS WORD LEVEL	RANGE	DEFAULT	SETTING LOCATION	SHOW WHEN UNIT TYPE IS
<b>HW / STEAM</b>					
VALVE POS		0.0 To 100%	Derived		Heat Type Equals Hot Water Heat Steam
FRZ STAT		Ok Tripped	Derived		
HEATING CONTROL OFFSET		1.0 °F To 100.0 °F	Derived		
<b>MOD FURNACE OUTPUT</b>					
RELATIVE		0.0 To 100%	Derived		Heat Type Equals Modulating Gas
APRX RATE		37.5 To 900.0 Mbh	Derived		
FURNACE 1A MODE		Off / Purge / Ignition / On - Low / On - High / Safety Trip / Safety Fault / Safety Lockout / Fault - L/O	Derived		Heating Type Equals Modulating Gas
<b>FURNACE 1A MODE</b>					
RELATIVE		0 To 100%	Derived		Heat Type Equals Modulating Gas
APRX RATE		37.5 To 150.0 Mbh	Derived		
FURNACE 1B MODE		Off / Purge / Ignition / On / Safety Trip / Safety Fault / Safety Lockout / Fault -L/O	Derived		Heat Type Equals Modulating Gas
FURNACE 1 MODE		Off / Purge / Ignition / On-Low / On - High / Safety Trip / Safety Fault / Safety Lockout / Fault -L/O	Derived		Heat Type Equals Staged Gas
FURNACE 2 MODE		Off / Purge / Ignition / On - Low / On - High / Safety Trip / Safety Fault / Safety Lockout / Fault -L/O	Derived		Gas Heat Size Equals 750 MBH Or 1125 MBH
FURNACE 3 MODE		Off / Purge / Ignition / On - Low / On -High / Safety Trip / Safety Fault / Safety Lockout / Fault -L/O	Derived		Gas Heat Size Equals 1125 MBH
HEATING SYSTEM	1	User Enabled User Disabled	User Enabled	Program / Heating	Heat Type Does Not Equal None
MORNING WARM UP	1	User Enabled User Disabled	User Disabled	Program / Heating	Heat Type Does Not Equal None And Constant Volume Control Method Does Not Equal Staged

**TABLE 31 – HEATING (CONT'D)**

DISPLAY TEXT	PASS WORD LEVEL	RANGE	DEFAULT	SETTING LOCATION	SHOW WHEN UNIT TYPE IS
ADAPT MORN WARM UP	1	User Enabled User Disabled	User Disabled	Program / Heating	Heat Type Does Not Equal None And Constant Volume Control Method Does Not Equal Staged
NIGHT SET BACK	1	User Enabled User Disabled	User Disabled	Program / Heating	Heat Type Does Not Equal None
HEAT LIMIT TEMPERATURE	2	100.0 °F - 150.0 °F	130.0 °F	Setpoints / Heating	Heat Type Does Not Equal None
HEATING SAT	1	80.0 °F - 115.0 °F	100.0 °F	Setpoints / Heating	Heat Type Does Not Equal None, Unit Type Equals Variable Air Volum, Flexsys
HW VALVE ACTION	2	Direct - Reverse	Direct	Program / Heating	Heating Type Equals Hot Water Steam
1ST STAGE HEATING SETPOINT	1	80.0 °F - 95.0 °F	85.0 °F	Setpoints / Heating	Heat Type Does Not Equal None And Unit Type Equals Constant Volume
2ND STAGE HEATING SETPOINT	1	95.0 °F - 115.0 °F	100.0 °F	Setpoints / Heating	Heat Type Does Not Equal None And Unit Type Equals Constant Volume
DAILY WARM UP TIME DAY 1		0 Min. To Morning Warm Up Max Time	Derived		Heat Type Does Not Equal None And Morn Warm Up Equals Enabled
DAILY WARM UP TIME DAY 2		0 Min. To Morning Warm Up Max Time	Derived		Heat Type Does Not Equal None And Morn Warm Up Equals Enabled
DAILY WARM UP TIME DAY 3		0 Min. To Morning Warm Up Max Time	Derived		Heat Type Does Not Equal None And Morn Warm Up Equals Enabled
DAILY WARM UP TIMER		0 Min. To Morning Warm Up Max Time	Derived		Heat Type Does Not Equal None And Morn Warm Up Equals Enabled
MORNING WARM UP OPT TIME		0 Min. To Morning Warm Up Max Time	Derived		Heat Type Does Not Equal None And Morn Warm Up Equals Enabled
MORNING WARM UP MAX TIME	1	15 - 240 Min.	120 Min.	Setpoints/Heating	Heat Type Does Not Equal None And Morn Warm Up Equals Enabled

\* Only the zone temp screen for the current active mode will be shown.

**TABLE 32 - ECONOMIZER**

DISPLAY TEXT	PASS WORD LEVEL	RANGE	DEFAULT	SETTING LOCATION	SHOW WHEN UNIT TYPE IS
<b>ECONO SYS STATUS</b>		Normal - Active / Normal - Inactive / Faulted / User Disabled / None	Derived		Always
<b>ECONO INSTALLED</b>	2	None / Drybulb / Single Enthalpy / Dual Enthalpy	None	Options / Economizer	Always
<b>ECONO METHOD TO USE</b>	1	Dry Bulb / Single Enthalpy / Dual Enthalpy / Best Available	Best Available	Options / Economizer	Economizer Installed Does Not Equal None
<b>ECONO METHOD ACTIVE</b>		Dry Bulb / Single Enthalpy / Dual Enthalpy	Derived		Economizer Installed Does Not Equal None
<b>ECONOMIZER CONTROL OUTPUT</b>		0 To 100%	Derived		Economizer Installed Does Not Equal None
<b>OUTSIDE AIR TEMP</b>		-20.0 °F To 180.0 °F	Look Up Table		Economizer Installed Does Not Equal None
<b>OUTSIDE AIR</b>					
<b>HUMIDITY</b>		0 To 100%	Look Up Table		Economizer Installed Equals Single Enthalpy Or Dual Enthalpy
<b>ENTHALPY</b>		7.2 To 204.9 BTU/LB	Look Up Table		Economizer Installed Equals Single Enthalpy Or Dual Enthalpy
<b>RETURN AIR TEMP</b>		-20.0 °F To 180.0 °F	Look Up Table		Economizer Installed Equals Dual Enthalpy
<b>RETURN AIR</b>					
<b>HUMIDITY</b>		0 To 100%	Look Up Table		Economizer Installed Equals Dual Enthalpy
<b>ENTHALPHY</b>		7.2 To 204.9 BTU/LB	Look Up Table		Economizer Installed Equals Dual Enthalpy
<b>OUTSIDE AIR ENTHALPY SETPOINT</b>	1	22.0 To 40.0 BTU/LB	28.0 BTU/LB	Setpoints / Economizer	Economizer Installed Does Not Equal None
<b>ECONOMIZER SYSTEM</b>	1	User Enabled User Disabled	Disabled	Program / Economizer	Economizer Installed Does Not Equal None



**TABLE 33 - VENTILATION**

DISPLAY TEXT	PASS WORD LEVEL	RANGE	DEFAULT	SETTING LOCATION	SHOW WHEN UNIT TYPE IS
<b>VENT SYS STATUS</b>		Normal - Active/ Normal - Inactive / Faulted / User Disabled / None	Derived		Always
<b>DAMPER HARDWARE</b>	2	None / 2 Position/ Standard/ Tek Air Full IAQ	Standard Dampers	Options / Ventilation	Always
<b>VENTILATION CONTROL</b>	1	Fixed Minimum / Demand	Fixed Minimum	Options / Ventilation	Damper Hardware Does Not Equal None Or 2 Position
<b>OA DAMPER POSITION</b>					
<b>CURRENT</b>		0.0 To 100%	Derived		Damper Hardware Does Not Equal
<b>ACTIVE SP</b>		0.0 To 100%	Derived		None
<b>VENTILATION DEMAND</b>		0-100%	Derived		Ventilation Control Equals Demand
<b>CO2 LEVEL</b>					
<b>OUTSIDE</b>		0 To 2000 PPM	Look Up Table		Ventilation Control Equals Demand
<b>INSIDE</b>		0 To 2000 PPM	Look Up Table		
<b>CO2 OFFSET</b>					
<b>CURRENT</b>		± 0 To 2000 PPM	Derived		Ventilation Control Equals Demand
<b>SETPOINT</b>	1	100-1000 PPM	500 PPM	Setpoints / Ventilation	
<b>OA DAMPER MINIMUM POSITION</b>	1	0 - OA Damper Maximum Position	15%	Setpoints / Ventilation	Damper Hardware Does Not Equal None Or 2 Position Damper
<b>OA DAMPER MAXIMUM POSITION</b>	1	OA Damper Minimum Position To 100%	30%	Setpoints / Ventilation	Damper Hardware Does Not Equal None Or 2 Position Damper
<b>CONTINUOUS VENT</b>	1	User Enabled User Disabled	User Enabled	Program / Ventilation	Unit Type Equals Constant Volume
<b>COMFORT VENTILATION</b>	1	User Enabled User Disabled	User Disabled	Program / Ventilation	Unit Type Equals Constant Volume
<b>OUTSIDE AIR MINIMUM FLOW</b>	1	Minimum - Derived Span X 5% Maximum - The Lower Of Derived Span X 50% And Outside Air Maximum Flow	Derived Span X 15%	Setpoints / Ventilation	Damper Hardware Tek-Air Control Set To Demand
<b>OUTSIDE AIR MAXIMUM FLOW</b>	1	Minimum - Outside Air Minimum Flow Maximum - Derived Flow	Derived Span X 30%	Setpoints / Ventilation	Damper Hardware Tek-Air Control Set To Demand
<b>MINIMUM OA FLOW SETPOINT</b>	1	0-100%	Derived Span X 15%	Setpoints / Ventilation	Damper Hardware Tek-Air And Ventilation Control Set To Fixed Minimum
<b>VENTILATION SYSTEM</b>	1	User Enabled User Disabled	User Enabled	Program / Ventilation	Damper Hardware Does Not Equal None

6

**TABLE 34 - EXHAUST**

DISPLAY TEXT	PASS WORD LEVEL	RANGE	DEFAULT	SETTING LOCATION	SHOW WHEN UNIT TYPE IS
<b>EXHAUST SYS STATUS</b>		Normal - Active / Normal - Inactive / Faulted / User Disabled / None	Derived		Always
<b>POWER EXHAUST TYPE</b>	2	None / On-Off Damper Ctrl / On-Off Press Cntrl / Modulate Damper - VFD / Return Fan W/ Exh / Return Fan W/O Exh	Setting	Options / Exhaust	Always
<b>BUILDING PRESSURE</b>					
<b>CURRENT</b>		-0.50 To 0.50" W.C.	Look Up Table		Power Exhaust Does Not Equal None Or On-Off Damper Ctrl
<b>ACTIVE SETPOINT</b>	1	-0.15 - +0.15" W.C.	0.00" W.C.	Setpoints / Exhaust	
<b>EXHAUST FAN</b>					
<b>OUTPUT</b>		On - Off	Derived		Power Exhaust Equals On Off Dampers Ctrl, On-Off Press Cntrl, Modulate Damper - VFD Fan
<b>STATUS</b>		Stopped / Running	Derived		
<b>EXHAUST DAMPER POSITION</b>		0.0 To 100%	Derived		Power Exhaust Equals Modulate Damper - VFD, Or Return Fan W/ Exh
<b>EXHAUST / RETURN FAN VFD</b>		0.0 To 100%	Derived		Power Exhaust Equals Modulate Damper - VFD
<b>BLDG PRESSURE CNTRL OFFSET</b>	1	- 0.15" W.C. To +0.15	0.00" W.C.	Setpoints / Exhaust	Power Exhaust Equals On - Off Press Ctrl
<b>ECONO OUTPUT FOR FAN START</b>	1	Econo Output For Fan Stop To 100%	10 %	Setpoints / Exhaust	Power Exhaust Equals On - Off Dmpr Ctrl
<b>ECONO OUTPUT FOR FAN STOP</b>	1	0 To Econo Output For Fan Start	5%	Setpoints / Exhaust	Power Exhaust Equals On - Off Dmpr Ctrl
<b>EXHAUST OUTPUT FOR FAN START</b>	1	Exhaust Output For Fan Stop To 100%	10%	Setpoints / Exhaust	Power Exhaust Equals Modulate Damper - VFD
<b>EXHAUST OUTPUT FOR FAN STOP</b>	1	0 - To Exhaust Output For Fan Start	5%	Setpoints / Exhaust	Power Exhaust Equals Modulate Damper - VFD

## SETPOINTS

All “Setpoints” values are numeric. Setpoints parameters can be viewed under their respective menu key on the left side of the keypad; however, they can only be changed under the SETPOINTS key using the following procedure. Press the SETPOINTS key to enter the “Setpoints” menu. The Enter Password screen will appear. All “Setpoints” parameters require the use of a password before they can be changed. See *Password on page 130* for information on how to enter a Password into the User Interface. If a Level 1 password is entered, only Level 1 setpoints will be available for change. Entering a Level 2 password will make all setpoints available. After the password has been accepted, use the ◀ key or the ▶ key to select the menu subsection: Unit, Cooling, Compressor Systems, Supply System, Heating, Economizer, Ventilation, or Exhaust, that contains the parameter you would like to change. The “Setpoints” contained under each of these menu subsections and their password level is contained in the tables 25 thru 33. Then use the ▼ key and the ▲ key to navigate to the parameter you want to change. Follow the instructions given in *Data Entry Keys on page 101* to change the value.

## PROGRAM

All “Program” information is USER ENABLED/ USER DISABLED values. Program parameters can be viewed under their respective menu key on the left side of the keypad; however, they can only be changed under the PROGRAM key using the following procedure. Press the PROGRAM key to enter the “Program” menu. The Enter Password screen will appear. All Program parameters require the use of a password before they can be changed. See *Password on page 130* for information on how to enter a Password into the User Interface. If a Level 1 password is, entered only Level 1 “program” information will be available for change. Entering a Level 2 password will make all “program” information available. After the password has been accepted, use the ◀ key or the ▶ key to select the menu subsection: Unit, Cooling, Compressor Systems, Supply System, Heating, Economizer, Ventilation, Exhaust, which contains the parameter you would like to change. The parameters contained under each of these menu subsections and their password level are contained in *Table 26 on page 103* through *Table 34 on page 114*. Then use the ▼ key and the ▲ key to navigate to the parameter you want to change. Follow the instructions given in the Data Entry keys section to change the parameter to the desired value.

## OPTIONS

All “Options” information is selected from the listed parameter data. Options parameters can be viewed under their respective menu key on the left side of the keypad; however, they can only be changed under the OPTIONS key using the following procedure. Press the OPTIONS key to enter the “Options” menu. The Enter Password screen will appear. All Option parameters require the use of a password before they can be changed. See *Password on page 130* for information on how to enter a Password into the User Interface. If a Level 1 password is entered, only Level 1 “options” information will be available for change. Entering a Level 2 password will make all “options” information available. After the password has been accepted, use the ◀ key or the ▶ key to select the menu subsection: Unit, Cooling, Compressor Systems, Supply System, Heating, Economizer, Ventilation, or Exhaust that contains the parameter you would like to change. The parameters contained under each of these menu subsections and their password level are contained in *Table 26 on page 103* through *Table 34 on page 114*. Then use the ▼ key and the ▲ key to navigate to the parameter you want to change. Follow the instructions given in the Data Entry keys section to change the parameter to the desired value.

## DATE / TIME

To change the day, time, and date press the DATE/ TIME key. The ▼ key is used to scroll to the next item to be programmed and the ▲ key scrolls to the previous item. The following messages will be displayed. The first line will be an active display and the second line will be the entry line.

CLOCK FRI 18 JUN 2004 10:15:33 AM
DAY OF MONTH =XX

CLOCK FRI 18 JUN 2004 10:15:33 AM
MONTH =XX

CLOCK FRI 18 JUN 2004 10:15:33 AM
YEAR =XXXX

CLOCK FRI 18 JUN 2004 10:15:33 AM
HOUR =XX

CLOCK FRI 18 JUN 2004 10:15:33 AM
MINUTE =XX

CLOCK FRI 18 JUN 2004 10:15:33 AM
DAY OF WEEK =XXX

CLOCK FRI 18 JUN 2004 10:15:33 AM
12 HOUR PERIOD =XX

CLOCK FRI 18 JUN 2004 10:15:33 AM
TIME FORMAT =XXXXXXXX

CLOCK FRI 18 JUN 2001 10:15:33 AM
POWER OFF TIME =XXXXX

Follow the instructions given in the section *Data Entry Keys on page 101* to change the above values.

## SCHEDULE

The “clock schedule” function can be USER ENABLED / USER DISABLED by using the schedule screen below.

To set the schedule, press the SCHEDULE key. The display will show the following message:

SCHEDULE ✓ TO EDIT
OCCUPANCY SCHEDULE USER ENABLED

SCHEDULE MON ✓ TO EDIT
+START =06:00 AM STOP =10:00 PM

SCHEDULE TUE ✓ TO EDIT
START =06:00 AM STOP =10:00 PM

SCHEDULE WED ✓ TO EDIT
START =06:00 AM STOP =10:00 PM

SCHEDULE THU ✓ TO EDIT
START =06:00 AM STOP =10:00 PM

SCHEDULE FRI ✓ TO EDIT
START =06:00 AM STOP =10:00 PM

SCHEDULE SAT ✓ TO EDIT
START =06:00 AM STOP =10:00 PM

SCHEDULE SUN ✓ TO EDIT
START =06:00 AM STOP =10:00 PM

To change the start or stop time, press the ✓ key. The line under the 0 is the cursor. If the start time is wrong, it may be changed from the numeric keypad. Once the correct value (hour and minute) is entered, press the ✓ key. The cursor will then move to the AM/PM selection. This value may be chosen by the +/- key and entered by pressing the ✓ key. This process may be followed until the hour, minutes, and meridian of both the START and STOP points are set. Press the ▼ key to get the schedule for the next day to appear. The start and stop time of each day may be programmed differently. If you want to view the schedule without making a change, simply press the ▼ key until the day you wish to view appears. The ▲ key will scroll backwards to the previous screen.

After the SUN (Sunday) schedule appears on the display, a subsequent press of the ▼ key will display the

SCHEDULE HOL
START =06:00 AM STOP =10:00 PM

Holiday schedule - This is a two-part display. The first reads:

The times may be set using the same procedure as described above for the days of the week.

SCHEDULE MMDD
HOLIDAY 01 = 1225

Continue pressing the ▼ key to set the 15 holiday dates. The display will read:

The month and the day of each holiday are entered in this format. Enter 0000 to not specify a holiday. The MMDD is displayed when the value is being edited to remind the operator what the format of this number is. Eg. 1225 represents December 25.

The line below the empty space is the cursor and will move to the next or previous empty space when the ◀ key or the ▶ key is pressed. To set the Holiday, the cursor is moved to the space following the day of the week of the holiday and the +/- key is pressed. An \* will appear in the space signifying that day as a holiday. The Holiday schedule must be programmed weekly. If there is no holiday, the +/- key is used to delete the \*. The ✓ key is used to accept the holiday schedule for the next seven days.

**OPERATING HOURS / START COUNTER**

Compressor Operating hours and Compressor Starts; Supply Fan Operating hours and Supply Fan starts; Exhaust Fan operating hours and Exhaust Fan starts; and Return Fan operating hours and Return Fan starts are displayed via one key press. The maximum value for both hours and starts is 99,999, at which point they will roll over to 0. Following are the displays.

**TABLE 35 - OPERATING HOURS / START COUNTER**

DISPLAY TEXT	PASS WORD LEVEL	RANGE	DEFAULT	SETTING LOCATION	SHOW WHEN
COMPRESSOR 1A OPER HRS COMPRESSOR 1A STARTS	1		Derived		
COMPRESSOR 1B OPER HRS COMPRESSOR 1B STARTS	1		Derived		
COMPRESSOR 2A OPER HRS COMPRESSOR 2A STARTS	1		Derived		
COMPRESSOR 2B OPER HRS COMPRESSOR 2B STARTS	1		Derived		
COMPRESSOR 3A OPER HRS COMPRESSOR 3A STARTS	1		Derived		Number Of Comps 6. Unit Capacity Equals 70 Ton, 75 Ton, 80 Ton, 85 Ton, 90 Ton, 95 Ton, 105 Ton, 106 Ton, 110 Ton, 115 Ton, 130 Ton, 150 Ton.
COMPRESSOR 3B OPER HRS COMPRESSOR 3B STARTS	1		Derived		
CONDENSER FAN 1A					
CONDENSER FAN 1B					
CONDENSER FAN 2A					
CONDENSER FAN 2B					
CONDENSER FAN 3A					Number Of Comps 6. Unit Capacity Equals 70 Ton, 75 Ton, 80 Ton, 85 Ton, 90 Ton, 95 Ton, 105 Ton, 106 Ton, 110 Ton, 115 Ton, 130 Ton, 150 Ton.
CONDENSER FAN 3B					
EXHAUST FAN OPER HRS EXHAUST FAN STARTS	1		Derived		Power Exhaust On/Off Dmpr / On/Off Press / Modulate Damper - VFD.
SUPPLY FAN OPER HRS SUPPLY FAN STARTS	1		Derived		
RETURN FAN OPER HRS RETURN FAN STARTS	1		Derived		Supply System Type Equals Return Fan W/Exh Return W/O Exhaust.

Below shows a typical screen example:

HOURS / STARTS OPER HRS. XXXXX
COMPRESSOR 1A STARTS XXXXX

## PRINTER

The Unit Controller has the capability of being connected through the RS-232 serial port, Port 2, to a computer using Hyper Terminal. A NUL MODEM cable must be used to connect the computer to the Unit Controller.

### Set Up

The computer must be connected to Port 2 of the Unit Controller. Use the SERVICE key to verify that Port 2 is configured to “TERMINAL”.

Press the PRINT key on the key pad. Use the down arrow key to set the following:

- PRINTER BAUD RATE
- PRINTER PARITY
- PRINTER STOP BITS
- PRINTER ROWS PER PAGE

These parameters must be set identical to the settings in Hyper Terminal. In addition the data bits must be set to 8 and Flow Control to None.

To use Hyper Terminal to save a report to a file:

- Select “Transfer – Transfer Text” and enter a file name to save the report in.
- From the Unit Controller panel, select the report you want to print. *See the following section, Report Section, to select the report.*
- As the report is uploading, from the Unit Control lerto the PC; it is displayed in the Hyper Terminal window.
- When the reports finish transferring to the file, select “Transfer – Capture Text – Stop.”
- The file can then be printed from an application like Notepad or Word.

To use Hyper Terminal to print a report without saving it to a file:

- Select “Transfer – Capture to Printer.”
- From the Unit Controller panel, select the report you want to print. *See the following section, Report Section, to select the report.*
- As the report is uploading, from the Unit Control lerto the PC; it is displayed in the Hyper Terminal window.
- After the reports finish transferring to the PC, select “Transfer – Capture to Printer” to send the last page to the printer.

## Report Section

Press the PRINT key and enter the password. Press the CHECK key. Use the left or right arrow key to navigate through the menu. The following reports are available to be printed:

STATUS  
UNIT DATA  
COOLING  
COMP SYSTEM  
SUPPLY SYSTEM  
HEATING  
ECONOMIZER  
VENTILATION  
EXHAUST  
SETPOINTS  
PROGRAM  
OPTIONS  
DATE / TIME  
SCHEDULE  
HOURS / STARTS  
SERVICE  
HISTORY BUFFER 1  
HISTORY BUFFER 2  
HISTORY BUFFER 3  
HISTORY BUFFER 4  
HISTORY BUFFER 5  
HISTORY BUFFER 6  
HISTORY BUFFER 7  
HISTORY BUFFER 8  
HISTORY BUFFER 9  
HISTORY BUFFER 10  
RUN TEST  
PRINT ALL REPORTS

After you have selected the report you want to print, press the ✓ key to output the report to the computer.

## SERVICE

To enter Service Mode, press the SERVICE key. The following message is the initial screen and is displayed when the SERVICE key is pressed, unless a Level 2 password is active.

SERVICE ENTER PASSWORD
---------------------------

All the DIGITAL outputs (DO) except for the compressors can be forced ON. In order to force the outputs the LOCAL STOP switch must be in the OFF position. To force an output ON use the ◀ or ▶ key to navigate to the SERVICE DO section. Then use the ▲ or ▼ key to select the output you want to force ON. Press the ✓ key and then use the ▶ key to switch it from OFF to ON. Press the ✓ key again to energize the output. Repeat the above process in reverse to turn the forced output back to OFF.

All the ANALOG outputs (AO) can be forced ON. In order to force the outputs the LOCAL STOP switch must be in the OFF position. To force an output ON use the ◀ or ▶ key to navigate to the SERVICE AO section. Then use the ▲ or ▼ key to select the output you want to force ON. Press the ✓ key and then use the numeric key pad to enter the output value. Press the ✓ key again to energize the output. Repeat the above process in reverse to turn the forced output back to 0.0. *Failure to do so will leave the forced output value in place until a different value is initiated by the operation of the unit.*

The ▶ key can be used to jump to the beginning of the next section of displays and the ◀ key can be used to jump to the beginning of the previous section of displays. The sections of displays are as follows:

- Parameters
- Analog Inputs
- Digital Inputs
- Digital Outputs
- Analog Outputs

The *Table 36 on page 120* lists the Displayed Text, Input or Output Type, Unit Controller terminal location (ID), Value Range, and when item is displayed.

**TABLE 36 - SERVICE**

DISPLAY TEXT	TYPE	ID	VALUE RANGE	LOCATION	DESCRIPTION
<b>DATA LOG FORMAT</b>			Off		Used To Activate The Data Log Feature Of The Control
<b>DATA LOG ERROR</b>	Error Detail		See Table 55 on page 184		Data Log Error Detail (Only Displayed When Error Is Present)
	Error State		See Table 54 on page 184		Data Log Error State (Only Displayed When Error Is Present)
<b>UPDATE FLASH</b>			On / Off		Used To Update Control Software
<b>UPDATE FLASH ERROR</b>					Description Of The Error (Only Displayed When Error Is Present)
<b>FACTORY RUN TESTER</b>			User Disable / User Enable		Only Used For Factory Run Test
<b>COMPRESSOR 1A</b>	Digital Output	TB4-2	On / Off	I/O Board	Status Of The Digital Output To Compressor 1A
<b>COMPRESSOR 1B</b>	Digital Output	TB4-3	On / Off	I/O Board	Status Of The Digital Output To Compressor 1B
<b>COMPRESSOR 2A</b>	Digital Output	TB4-4	On / Off	I/O Board	Status Of The Digital Output To Compressor 2A
<b>COMPRESSOR 2B</b>	Digital Output	TB4-5	On / Off	I/O Board	Status Of The Digital Output To Compressor 2B
<b>COMPRESSOR 3A</b>	Digital Output	TB4-7	On / Off	I/O Board	Status Of The Digital Output To Compressor 3A
<b>COMPRESSOR 3B</b>	Digital Output	TB4-8	On / Off	I/O Board	Status Of The Digital Output To Compressor 3B
<b>CONDENSER FAN 1A/1</b>	Digital Output	TB4-9	On / Off	I/O Board	Status Of Digital Output To Condenser Fan 1A
<b>CONDENSER FAN 1B/2</b>	Digital Output	TB4-9	On / Off	I/O Board	Status Of Digital Output To Condenser Fan 1B
<b>CONDENSER FAN 2A/3</b>	Digital Output	TB6-2	On / Off	I/O Board	Status Of Digital Output To Condenser Fan 2A
<b>CONDENSER FAN 2B/4</b>	Digital Output	TB6-2	On / Off	I/O Board	Status Of Digital Output To Condenser Fan 2B
<b>CONDENSER FAN 3A/5</b>	Digital Output	TB6-4	On / Off	I/O Board	Status Of Digital Output To Condenser Fan 3A
<b>CONDENSER FAN 3B/6</b>	Digital Output	TB6-4	On / Off	I/O Board	Status Of Digital Output To Condenser Fan 3B
<b>ELECTRIC HEAT STG 1</b>	Digital Output	TB3-2	On / Off	I/O Board	Status Of Electric Heat Digital Output To Stage 1
<b>ELECTRIC HEAT STG 2</b>	Digital Output	TB3-3	On / Off	I/O Board	Status Of Electric Heat Digital Output To Stage 2
<b>ELECTRIC HEAT STG 3</b>	Digital Output	TB3-4	On / Off	I/O Board	Status Of Electric Heat Digital Output To Stage 3
<b>ELECTRIC HEAT STG 4</b>	Digital Output	TB3-5	On / Off	I/O Board	Status Of Electric Heat Digital Output To Stage 4
<b>ELECTRIC HEAT STG 5</b>	Digital Output	TB3-7	On / Off	I/O Board	Status Of Electric Heat Digital Output To Stage 5
<b>ELECTRIC HEAT STG 6</b>	Digital Output	TB3-8	On / Off	I/O Board	Status Of Electric Heat Digital Output To Stage 6



**TABLE 36 – SERVICE (CONT'D)**

DISPLAY TEXT	TYPE	ID	VALUE RANGE	LOCATION	DESCRIPTION
<b>ELECTRIC HEAT STG 7</b>	Digital Output	TB3-9	On / Off	I/O Board	Status Of Electric Heat Digital Output To Stage 7
<b>STG GAS FURN 1 LOW</b>	Digital Output	TB3-2	On / Off	I/O Board	Status Of Staged Gas Heat Digital Output To Stage 1 Low
<b>STG GAS FURN 1 HIGH</b>	Digital Output	TB3-3	On / Off	I/O Board	Status Of Staged Gas Heat Digital Output To Stage 1 High
<b>STG GAS FURN 2 LOW</b>	Digital Output	TB3-4	On / Off	I/O Board	Status Of Staged Gas Heat Digital Output To Stage 2 Low
<b>STG GAS FURN 2 HIGH</b>	Digital Output	TB3-5	On / Off	I/O Board	Status Of Staged Gas Heat Digital Output To Stage 2 High
<b>STG GAS FURN 3 LOW</b>	Digital Output	TB3-7	On / Off	I/O Board	Status Of Staged Gas Heat Digital Output To Stage 3 Low
<b>STG GAS FURN 3 HIGH</b>	Digital Output	TB3-8	On / Off	I/O Board	Status Of Staged Gas Heat Digital Output To Stage 3 High
<b>MOD GAS FURN 1A LOW</b>	Digital Output	TB3-2	On / Off	I/O Board	Status Of Mod Gas Heat Digital Output To Stage 1A Low
<b>MOD GAS FURN 1A HI</b>	Digital Output	TB3-3	On / Off	I/O Board	Status Of Mod Gas Heat Digital Output To Stage 1A High
<b>MOD GAS FURN 2 LOW</b>	Digital Output	TB3-4	On / Off	I/O Board	Status Of Mod Gas Heat Digital Output To Stage 2 Low
<b>MOD GAS FURN 2 HIGH</b>	Digital Output	TB3-5	On / Off	I/O Board	Status Of Mod Gas Heat Digital Output To Stage 2 High
<b>MOD GAS FURN 3 LOW</b>	Digital Output	TB3-7	On / Off	I/O Board	Status Of Mod Gas Heat Digital Output To Stage 3 Low
<b>MOD GAS FURN 3 HIGH</b>	Digital Output	TB3-8	On / Off	I/O Board	Status Of Mod Gas Heat Digital Output To Stage 3 High
<b>MOD GAS FURN 1B</b>	Digital Output	TB3-9	On / Off	I/O Board	Status Of Mod Gas Heat Digital Output To Stage 1B
<b>PUMP DOWN LLSV 1</b>	Digital Output	TB5-2	On / Off	I/O Board	Status Of Pump Down Solenoid Llsv 1 Digital Output
<b>PUMP DOWN LLSV 2</b>	Digital Output	TB5-4	On / Off	I/O Board	Status Of Pump Down Solenoid Llsv 2 Digital Output
<b>PUMP DOWN LLSV 3</b>	Digital Output	TB5-6	On / Off	I/O Board	Status Of Pump Down Solenoid Llsv 3 Digital Output
<b>SUPPLY FAN OUTPUT</b>	Digital Output	TB1-2	On / Off	Always	Status Of Supply Fan Digital Output
<b>RETURN FAN OUTPUT</b>	Digital Output	TB1-4	On / Off	I/O Board	Status Of Return Fan Digital Output
<b>EXHAUST FAN OUTPUT</b>	Digital Output	TB1-4	On / Off	I/O Board	Status Of Exhaust Fan Or Return Fan Digital Output
<b>VAV HEAT RELAY</b>	Digital Output	TB1-12	On / Off	I/O Board	Status Of The Digital Output For The Vav Heat Relay
<b>FAN FAULT</b>	Digital Output	TB1-6	Okay / Faulted	I/O Board	Digital Output That Is Generated When There Is A Supply Fan Fault
<b>COOL/HEATING FAULT</b>	Digital Output	TB1-8	On / Off	I/O Board	Digital Output That Is Generated When There Is A Cooling/Heating Fault
<b>SENSOR/MISC FAULT</b>	Digital Output	TB1-10	On / Off	I/O Board	Digital Output That Is Generated When There Is A Sensor/Misc Fault

**TABLE 36 – SERVICE (CONT'D)**

DISPLAY TEXT	TYPE	ID	VALUE RANGE	LOCATION	DESCRIPTION
<b>SUPPLY FAN VFD SPEED</b>	Analog Output	TB9-1	0-10 Volt Dc	I/O Board	Analog Output To The Supply Fan VFD
<b>EXHAUST DAMPER POSITION</b>	Analog Output	TB9-7	0-10 Volts Dc	I/O Board	Analog Output To The Exhaust Damper
<b>EXHAUST / RETURN FAN VFD</b>	Analog Output	TB9-3	0-10 Volts Dc	I/O Board	Analog Output To The Exhaust Or Return Fan VFD
<b>OA DAMPER POSITION</b>	Analog Output	TB9-5	0-10 Volts Dc	I/O Board	Analog Output To The Economizer Dampers
<b>HEATING VALVE</b>	Analog Output	TB9-9	0-10 Volts Dc	I/O Board	Analog Output To The Heating Valve
<b>BYPASS DAMPER POSITION</b>	Analog Output	TB9-11	0-10 Volts Dc	I/O Board	Analog Output To The Flexsys Bypass Damper
<b>SUPPLY AIR TEMP CURRENT</b>	Analog Input	J1-1	0-5 Volts	I/O Board	Analog Input From The Supply Or Mixed Air Sensor
<b>MX SUPPLY AIR TEMP CURRENT</b>	Analog Input	J1-1	0-5 Volts	I/O Board	Analog Input From The Supply Or Mixed Air Sensor
<b>HEAT EXCHANGER TEMP</b>	Analog Input	J1-2	0-5 Volts	I/O Board	Analog Input From The Temperature Sensor Positioned Before The Heat Section
<b>FLEX EVAP TEMP CURRENT</b>	Analog Input	J1-3	0-5 Volts	I/O Board	Analog Input From The Temperature Sensors Positioned On The Leaving Side Of The Evaporator Coil
<b>OUTSIDE AIR TEMP</b>	Analog Input	J2-1	0-5 Volts	I/O Board	Analog Input From The Outdoor Air Temperature Sensor
<b>RETURN AIR TEMP CURRENT</b>	Analog Input	J2-2	0-5 Volts	I/O Board	Analog Input From The Return Air Temperature Sensor
<b>OUTSIDE AIR HUMIDITY</b>	Analog Input	J2-3	0-5 Volts	I/O Board	Analog Input From The Outdoor Air Humidity Sensor
<b>RETURN AIR HUMIDITY</b>	Analog Input	J2-4	0-5 Volts	I/O Board	Analog Input From The Return Air Humidity Sensor
<b>TEMPERATURE SUCTION 1</b>	Analog Input	J3-1	0-5 Volts	I/O Board	Analog Input From The System 1 Suction Line Temperature Sensor
<b>TEMPERATURE SUCTION 2</b>	Analog Input	J3-2	0-5 Volts	I/O Board	Analog Input From The System 2 Suction Line Temperature Sensor
<b>TEMPERATURE SUCTION 3</b>	Analog Input	J3-3	0-5 Volts	I/O Board	Analog Input From The System 3 Suction Line Temperature Sensor
<b>PRESSURE SUCTION 1</b>	Analog Input	J3-4	0-5 Volts	I/O Board	Analog Input From The System 1 Suction Pressure Transducer
<b>PRESSURE SUCTION 2</b>	Analog Input	J4-1	0-5 Volts	I/O Board	Analog Input From The System 2 Suction Pressure Transducer
<b>PRESSURE SUCTION 3</b>	Analog Input	J4-2	0-5 Volts	I/O Board	Analog Input From The System 3 Suction Pressure Transducer
<b>PRESSURE DISCHARGE 1</b>	Analog Input	J4-3	0-5 Volts	I/O Board	Analog Input From The System 1 Discharge Pressure Transducer
<b>PRESSURE DISCHARGE 2</b>	Analog Input	J4-4	0-5 Volts	I/O Board	Analog Input From The System 2 Discharge Pressure Transducer

**TABLE 36 – SERVICE (CONT'D)**

DISPLAY TEXT	TYPE	ID	VALUE RANGE	LOCATION	DESCRIPTION
<b>PRESSURE DISCHARGE 3</b>	Analog Input	J4-5	0-5 Volts	I/O Board	Analog Input From The System 3 Discharge Pressure Transducer
<b>CO2 LEVEL OUTSIDE</b>	Analog Input	J5-2	0-5 Volts	I/O Board	Analog Input Of The Outdoor CO <sub>2</sub> Sensor
<b>CO2 LEVEL INSIDE</b>	Analog Input	J5-3	0-5 Volts	I/O Board	Analog Input From The Indoor CO <sub>2</sub> Sensor
<b>RETURN FAN PRESS CURRENT</b>	Analog Input	J6-1	0-5 Volts	I/O Board	Analog Input From The Return Fan Pressure Transducer
<b>DUCT STATIC PRESS CURRENT</b>	Analog Input	J6-2	0-5 Volts	I/O Board	Analog Input From The Supply Air Pressure Transducer
<b>BUILDING PRESSURE CURRENT</b>	Analog Input	J6-3	0-5 Volts	I/O Board	Analog Input From The Building Pressure Transducer
<b>OA FLOW INPUT 1</b>	Analog Input	J6-4	0 To 4095 A/D Counts (1-5 Volts)	I/O Board	This Is The Air Flow Input From The Tek Air Measuring Station
<b>OA FLOW INPUT 2</b>	Analog Input	J6-5	0 To 4095 A/D Counts (1-5 Volts)	I/O Board	This Is The Air Flow Input From The Tek Air Measuring Station
<b>OA FLOW PRESSURE 1</b>	Analog Input	J6-4	0 To 0.25" W.C. (0-5 Volts)	I/O Board	Analog Input From The Air Measuring Station Pressure Transducer
<b>OA FLOW PRESSURE 2</b>	Analog Input	J6-5	0 To 0.25" W.C. (0-5 Volts)	I/O Board	Analog Input From The Air Measuring Station Pressure Transducer
<b>OA FLOW VELOCITY 1</b>	Analog Input	J6-4	0 To 2002 Fpm (0-5 Volts)	I/O Board	Analog Input From The Air Measuring Station Pressure Transducer
<b>OA FLOW VELOCITY 2</b>	Analog Input	J6-5	0 To 2002 Fpm (0-5 Volts)	I/O Board	Analog Input From The Air Measuring Station Pressure Transducer
<b>ZONE TEMP CURRENT</b>	Analog Input	J7-1	0-5 Volts	I/O Board	Analog Input From The Zone Temperature Sensor
<b>UNDERFLOOR SLAB TEMP</b>	Analog Input	J7-2	0-5 Volts	I/O Board	Analog Input From The Under Floor Temperature Sensor
<b>UNDERFLOOR AIR HUMIDITY</b>	Analog Input	J7-3	0-5 Volts	I/O Board	Analog Input From The Underfloor Humidity Sensor
<b>SUPPLY AIR TEMP RST</b>	Analog Input	J7-4	0-5 Volts	I/O Board	Hardwired Analog Input To Reset The Supply Air Temperature Setpoint
<b>DUCT STATIC PRES RESET</b>	Analog Input	J7-5	0-5 Volts	I/O Board	Hardwired Analog Input To Reset The Duct Static Pressure Setpoint
<b>FURNACE STATUS</b>	Analog Input	J5-1	0-5 Volts	I/O Board	Analog Input Of The Furnace Multiplexer
<b>FURNACE 1A STAT HI</b>	Digital Input	TB01-3	On / Off	Furnace Multiplexer	Furnace 1A Hz Status Input To Furnace Multiplexer Board
<b>FURNACE STATUS COUNTS</b>	Analog Input	J5-1	0 - 4095	I/O Board	Status Of The Input From The Furnace Multiplexer Board In Count
<b>FURNACE 1 STATUS</b>	Digital Input	TB01-2	On / Off	Furnace Multiplexer	Furnace 1 Status Input To Furnace Multiplexer Board
<b>FURNACE 1A STATUS</b>	Digital Input	TB01-2	On / Off	Furnace Multiplexer	Furnace 1A Status Input To Furnace Multiplexer Board
<b>FURNACE 1B STATUS</b>	Digital Input	TB01-6	On / Off	Furnace Multiplexer	Furnace 1B Status Input To Furnace Multiplexer Board

**TABLE 36 – SERVICE (CONT'D)**

DISPLAY TEXT	TYPE	ID	VALUE RANGE	LOCATION	DESCRIPTION
<b>FURNACE 2 STATUS</b>	Digital Input	TB01-3	On / Off	Furnace Multiplexer	Furnace 2 Status Input To Furnace Multiplexer Board
<b>FURNACE 3 STATUS</b>	Digital Input	TB01-4	On / Off	Furnace Multiplexer	Furnace 3 Status Input To Furnace Multiplexer Board
<b>OCCUPANCY STATE</b>	Digital Input	TB8-2	Occupied / Unoccupied	I/O Board	Hardwired Digital Input To Put The Unit Into The Occupied Mode
<b>LOCAL STOP</b>	Digital Input	TB8-1	Run / Stop	I/O Board	Digital Input That Turns The Unit On And Off
<b>FAN (G)</b>	Digital Input	TB8-8	On / Off	I/O Board	Hardwired Digital Input To Turn The Supply Fan On And Off
<b>Y1 LOW COOL</b>	Digital Input	TB8-10	On / Off	I/O Board	Hardwired Digital Input To Place The Unit In First Stage Cooling Mode
<b>Y2 HIGH COOL</b>	Digital Input	TB8-11	On / Off	I/O Board	Hardwired Digital Input To Place The Unit In Second Stage Cooling Mode
<b>W1 LOW HEAT</b>	Digital Input	TB8-13	On / Off	I/O Board	Hardwired Digital Input To Place The Unit In First Stage Heating Mode
<b>W2 HIGH HEAT</b>	Digital Input	TB8-14	On / Off	I/O Board	Hardwired Digital Input To Place The Unit In Second Stage Heating Mode
<b>SAFETY INPUT CHAIN 1</b>	Digital Input	TB7-1	Okay / Faulted	I/O Board	Digital Input From The Compressor System 1 Safety Circuit
<b>SAFETY INPUT CHAIN 2</b>	Digital Input	TB7-2	Okay / Faulted	I/O Board	Digital Input From The Compressor System 2 Safety Circuit
<b>SAFETY INPUT CHAIN 3</b>	Digital Input	TB7-4	Okay / Faulted	I/O Board	Digital Input From The Compressor System 3 Safety Circuit
<b>SAFETY INPUTS LPCO 1</b>	Digital Input	TB7-5	Okay / Faulted	I/O Board	Digital Input From The Compressor System 1 Low Pressure Safety Circuit
<b>SAFETY INPUTS LPCO 2</b>	Digital Input	TB7-7	Okay / Faulted	I/O Board	Digital Input From The Compressor System 2 Low Pressure Safety Circuit
<b>SAFETY INPUTS LPCO 3</b>	Digital Input	TB7-8	Okay / Faulted	I/O Board	Digital Input From The Compressor System 3 Low Pressure Safety Circuit
<b>SUPPLY FAN OUTPUT</b>	Digital Input	TB7-10	Running / Stopped	I/O Board	Digital Input For The Supply Fan Run Verification Circuit
<b>EXHAUST FAN STATUS</b>	Digital Input	TB7-11	Running / Stopped	I/O Board	Digital Input From The Exhaust Fan Run Verification Circuit
<b>RETURN FAN STATUS</b>	Digital Input	TB7-11	Running / Stopped	I/O Board	Digital Input From The Return Fan Run Verification Circuit
<b>FILTER STATUS</b>	Digital Input	TB7-13	Okay / Change	I/O Board	Digital Input From The Dirty Filter Pressure Switch
<b>HW/STEAM FRZ STAT</b>	Digital Input	TB7-14	Okay / Faulted	I/O Board	Digital Input From The Hot Water Freezestat
<b>SMOKE PURGE 1</b>	Digital Input	TB8-4	On / Off	I/O Board	Hardwired Digital Input To Place The Unit In Smoke Purge 1 Mode
<b>SMOKE PURGE 2</b>	Digital Input	TB8-5	On / Off	I/O Board	Hardwired Digital Input To Place The Unit In Smoke Purge 2 Mode
<b>SMOKE PURGE 3</b>	Digital Input	TB8-7	On / Off	I/O Board	Hardwired Digital Input To Place The Unit In Smoke Purge 3 Mode

**TABLE 36 – SERVICE (CONT'D)**

DISPLAY TEXT	TYPE	ID	VALUE RANGE	LOCATION	DESCRIPTION
<b>CO2 LVL INSIDE BAS</b>	Commun	Port P1	User Disable / User Enable	IPU Board	This Item Must Be Enabled In Order To Communicate A CO <sub>2</sub> Value To The Unit
<b>CO2 LVL INSIDE VALUE BAS</b>	Commun	Port P1	101 To 1899 Ppm	IPU Board	The Inside CO <sub>2</sub> Value Being Communicated To The Unit Through The Bas System
<b>DUCT PRES RESET BAS</b>	Commun	Port P1	User Disable / User Enable	IPU Board	This Item Must Be Enabled In Order To Communicate A Duct Static Pressure Reset Value To The Unit
<b>DUCT STATIC PRES RESET BAS</b>	Commun	Port P1	0 To 100%	IPU Board	The Duct Static Reset Value Being Communicated To The Unit Through The Bas System
<b>EXHAUST CONTROL BAS</b>	Commun	Port P1	Enable/Disable	IPU Board	Enables or disables control of the Modulating Exhaust Damper (Return Fan)
<b>EXHAUST DAMPER/VFD</b>	Commun	Port P1	0 To 100%	IPU Board	Communicates signal to set the position of the Modulating Damper (Return Fan) or speed of the Exhaust Fan.
<b>FAN (G) BAS</b>	Commun	Port P1	On / Off	IPU Board	Gives The Status Of The Communicated Fan G Input
<b>MORNING WARM UP CMD</b>	Commun	Port P1	On / Off	IPU Board	Gives The Status Of The Communicated Morning Warm Up Command
<b>OCCUPANCY COMMAND</b>	Commun	Port P1	Occupied / Unoccupied	IPU Board	Gives The Status Of The Communicated Occupancy Command
<b>SMOKE PURGE 1 BAS</b>	Commun	Port P1	On Off	IPU Board	Gives The Status Of The Communicated Smoke Purge 1 Command
<b>SMOKE PURGE 2 BAS</b>	Commun	Port P1	On Off	IPU Board	Gives The Status Of The Communicated Smoke Purge 2 Command
<b>SMOKE PURGE 3 BAS</b>	Commun	Port P1	On Off	IPU Board	Gives The Status Of The Communicated Smoke Purge 3 Command
<b>SAT RESET BAS</b>	Commun	Port P1	User Disable / User Enable	IPU Board	This Item Must Be Enabled In Order To Communicate A Supply Air Temperature Reset Value To The Unit
<b>SUPPLY AIR TEMP RESET BAS</b>	Commun	Port P1	0 To 5 Volts	IPU Board	The Supply Air Temperature Reset Value Being Communicated To The Unit Through The Bas System
<b>SYSTEM STOP</b>	Commun	Port P1	0 - Allows All Compressors To Operate; 1 - Turns Off Compressor System 1; 2 - Turns Off Compressor System 2; 3 - Turns Off Compressor System 3	IPU Board	Gives The Status Of The Communicated System Stop Command

**6**

**TABLE 36 – SERVICE (CONT'D)**

DISPLAY TEXT	TYPE	ID	VALUE RANGE	LOCATION	DESCRIPTION
<b>UNDER FLR HUMI BAS</b>	Commun	Port P1	User Disable / User Enable	IPU Board	This Item Must Be Enabled In Order To Communicate A Under Floor Humidity Value To The Unit
<b>UNDRFLOOR AIR HUMIDITY BAS</b>	Commun	Port P1	0 To 100%	IPU Board	The Under Floor Humidity Value Being Communicated To The Unit
<b>UNDR FLR TEMP BAS</b>	Commun	Port P1	User Disable / User Enable	IPU Board	This Item Must Be Enabled In Order To Communicate An Under Floor Temperature Value To The Unit
<b>UNDERFLOOR SLAB TEMP BAS</b>	Commun	Port P1	-20.0 °F To 180.0 °F	IPU Board	This Is The Actual Under Floor Temperature Value Being Communicated By The Bas System
<b>UNIT STOP</b>	Commun	Port P1	On / Off	IPU Board	Gives The Status Of The Communicated Unit Stop Command
<b>W1 LOW HEAT BAS</b>	Commun	Port P1	On / Off	IPU Board	Gives The Status Of The Communicated W1 Low Heat Command
<b>W2 HIGH HEAT BAS</b>	Commun	Port P1	On / Off	IPU Board	Gives The Status Of The Communicated W2 High Heat Command
<b>Y1 LOW COOL BAS</b>	Commun	Port P1	On / Off	IPU Board	Gives The Status Of The Communicated Y1 Low Cool Command
<b>Y2 HIGH COOL BAS</b>	Commun	Port P1	On / Off	IPU Board	Gives The Status Of The Communicated Y2 High Cool Command
<b>ZONE TEMP BAS</b>	Commun	Port P1	-20.0 °F To 180.0 °F	IPU Board	Gives The Actual Value Of The Communicated Zone Temperature
<b>FIRMWARE CRC</b>	Derived		0 To 99999	Always	This Is The Size Of The Code In The Software And Is Not For Field Use
<b>REAL TIME UI - PEAK 5 SEC AND AVERAGE</b>	Derived				The Average And Peak Over The Last 5 Seconds Time Used By The User Interface. This Is Not For Field Use
<b>REAL TIME UI - LOST AND PEAK</b>	Derived				The Lost And Peak Time Used By The User Interface. This Is Not For Field Use
<b>REAL TIME CONTROL - PEAK 5 SEC AND AVERAGE</b>	Derived				The Average And Peak Over The Last 5 Seconds Time Used By The Control. This Is Not For Field Use
<b>REAL TIME CONTROL - LOST AND PEAK</b>	Derived				The Lost And Peak Time Used By The Control. This Is Not For Field Use
<b>DE MODIFIER ADDRESS</b>			-1 To 41943		Used To Enter A Specific De Instance. See <i>Communication on page 131</i> .
<b>DE MODIFIER OFFSET</b>			-1 To 99		Used In Combination With The De Modifier Address To Enter A Specific De Instance. See <i>Communication on page 131</i> .
<b>P1 BAUD RATE</b>			1200, 4800, 9600, 19200, 38400, 76800		Establishes The Communication Baud Rate For Port 1
<b>P1 MANUAL MAC ADDRESS</b>			-1 To 127		Allows The Manual Entrance Of The Mac Address For Port 1. See <i>Communication on page 131</i> .

**TABLE 36 – SERVICE (CONT'D)**

DISPLAY TEXT	TYPE	ID	VALUE RANGE	LOCATION	DESCRIPTION
<b>P1 PARITY</b>			None, Even, Odd, Ignore		Do Not Change From Default Value For Bacnet
<b>P1 PROTOCOL</b>			Bacnet, Api		Keep Setting On Bacnet
<b>P1 STOP BITS</b>			1-2		Do Not Change From Default Value For Bacnet
<b>P2 BAUD RATE</b>			1200, 4800, 9600, 19200, 38400, 57600		Establishes The Communication Baud Rate For Port 2
<b>P2 MANUAL MAC ADDRESS</b>			-1 To 127		Allows The Manual Entrance Of The Mac Address For Port 2. See <i>Communication on page 131.</i>
<b>P2 PARITY</b>			None, Even, Odd, Ignore		Establishes The Parity For Communication Port 2
<b>P2 PROTOCOL</b>			Terminal, Modbus I/O, Modbus Server, Api, Modbus Client		Establishes The Protocol For Communication Port 2
<b>P2 STOP BITS</b>			1 - 2		Establishes The Stop Bit Setting For Communication Port 2
<b>P3 BAUD RATE</b>			1200, 4800, 9600, 19200, 38400, 57600		Establishes The Communication Baud Rate For Port 3
<b>P3 MANUAL MAC ADDRESS</b>			-1 To 127		Allows The Manual Entrance Of The Mac Address For Port 3. See <i>Communication on page 131.</i>
<b>P3 PARITY</b>			None, Even, Odd, Ignore		Establishes The Parity For Communication Port 3
<b>P3 PROTOCOL</b>			Terminal, Modbus I/O, Modbus Server, Api, Modbus Client		Establishes The Protocol For Communication Port 3
<b>P3 STOP BITS</b>			1 - 2		Establishes The Stop Bit Setting For Communication Port 3
<b>P4 BAUD RATE</b>			1200, 4800, 9600, 19200, 38400, 57600		Establishes The Communication Baud Rate For Port 4
<b>P4 MANUAL MAC ADDRESS</b>			-1 To 127		Allows The Manual Entrance Of The Mac Address For Port 4. See <i>Communication on page 131.</i>
<b>P4 PARITY</b>			None, Even, Odd, Ignore		Establishes The Parity For Communication Port 4
<b>P4 PROTOCOL</b>			Terminal, Modbus I/O, Modbus Server, Api, Modbus Client		Establishes The Protocol For Communication Port 4
<b>P4 STOP BITS</b>			1 - 2		Establishes The Stop Bit Setting For Communication Port 4

**6**

**TABLE 36 – SERVICE (CONT'D)**

DISPLAY TEXT	TYPE	ID	VALUE RANGE	LOCATION	DESCRIPTION
CONNEXSYS ERROR FEATURE AND DETECTION	Derived				Not For Field Use
CONNEXSYS ERROR PAGE AND FIELD	Derived				Not For Field Use
CONNEXSYS ERROR REASON AND VALVE	Derived				Not For Field Use
REAL TIME PROBLEM STRING	Derived				Not For Field Use
REAL TIME PROBLEM NUMBER	Derived				Not For Field Use
REAL TIME PROBLEM	Derived				Not For Field Use

The following is an example of an ANALOG Input display that can be viewed from Service Mode. See *Table 36 on page 120* for a listing of the ANALOG Inputs.

SERVICE AI PIO J07-01 XX.X VDC + BUILDING STATIC PRES =XX.XXINWC
---

Following is an example of a DIGITAL Input display that can be viewed from Service Mode. See *Table 36 on page 120* for a listing of the DIGITAL Inputs.

SERVICE DI PIO TB08-01 LOCAL STOP RUN
--

Following is an example of a DIGITAL Output display that can be viewed from Service Mode. The XXX is replaced with OFF or ON in this section. See *Table 36 on page 120* for a listing of the DIGITAL Outputs.

SERVICE DO PIO TB03-05 COMPRESSOR 2A OFF
---

Following is an example of an ANALOG Output display that can be viewed from Service Mode. See *Table 36 on page 120* for a listing of the ANALOG Outputs

SERVICE AO PIO TB08-01 XX.X VDC + SYS 1 FEED VALVE OUTPUT =XXX.X %
---

## HISTORY

The HISTORY key gives the user access to WARNING and FAULT information. Many operating parameters and states are saved at the time of a fault. The History information can be viewed after entering the Level 2 password.

When the HISTORY key is pressed, the first active warning will be displayed. If there are not any active warnings, HISTORY 1 is displayed. If there are not any faults, “NO FAULT” will be displayed. Data is not saved for warnings. Data is saved for faults.

When a warning is displayed, the ► key advances to the next warning or HISTORY 1 after the last warning. The ◀ key returns to the previous warning or the highest HISTORY number before the first warning.

When a HISTORY # is displayed, the ► key advances to the next HISTORY # or warning 1 after the last fault. The ◀ key returns to the previous HISTORY # or the highest warning number before the first fault. Buffer number 1 is the most recent and buffer number 10 is the oldest HISTORY # saved. A maximum of 10 HISTORY #'s are saved. The ▲ and ▼ key can be used to scroll forwards and backwards through the history buffer data.

HISTORY key pressed

WARNING 1	WARNING 2	FAULT 1	FAULT 2	FAULT 3
		Fault 1 Data	Fault 2 Data	Fault 3 Data



The data following the initial History Fault display, is displayed in the same order and with the same message used under the respective menu function:

- Status
- Unit Data
- Cooling
- Supply System
- Comp Sys 1
- Comp Sys 2
- Comp Sys 3
- Heating
- Economizer
- Ventilation
- Exhaust
- Hours/Starts

Pressing the ▼ key from a History Fault display changes the display to the History Section display format. The ► and ◀ keys are used to select a section. Pressing the HISTORY or X key returns to the History Fault display. Pressing the ▼ key displays the next parameter in the selected list. From a parameter display, pressing the HISTORY or X key returns to the History Fault display. See *Navigation Keys on page 102* for instructions for navigating the parameter display.

For the following example, assume that there were three faults and one warning logged.

First, the HISTORY key is pressed to get the password prompt. If a level 2 password is active, this prompt is skipped.

```
HISTORY
ENTER PASSWORD
```

After entering the Level 2 password, the most recent WARNING is displayed.

```
HISTORY WARNING      ◀▶
+ WRN-BUILDING PRS
```

The ► key is pressed to move to the first fault.

```
HISTORY 01 31 OCT 2004 12:45:59 AM ◀▶
+ LOCKOUT-DUCT PRS XDCR
```

The ► key is pressed to move to the next older fault (fault # 2).

```
HISTORY 02 31 OCT 2004 10:42:39 AM ◀▶
AUTO RESET-MSAT SENSOR
```

The ► key is pressed to move to the next older fault (fault # 3).

```
HISTORY 03 30 OCT 2004 02:11:23 PM ◀▶
WRN-BUILDING PRS
```

The ▼ key is pressed to view data saved when fault #3 was detected.

```
HISTORY 03 – STATUS      ◀▶
UNIT-OVERALL STATUS  RUN
```

The ▼ key is pressed to view the second STATUS value.

```
HISTORY 03 – STATUS      ◀▶
CURRENT OPER MODE  RUN
```

The ► key is pressed to change to the next data section (UNIT DATA).

```
HISTORY 03 – UNIT DATA  ◀▶
UNIT TYPE  CONSTANT VOLUME
```

The X or HISTORY key is pressed to go back to the fault display.

```
HISTORY 03 30 OCT 2004 02:11:23 PM ◀▶
WRN-BUILDING PRS
```

From fault display, the X key can be pressed to return to the Power Up Banner display.

## PASSWORD

Passwords are used to allow restricted access to the modification and viewing of certain parameters using the SETPOINTS, PROGRAM, OPTIONS, DATE/TIME, SCHEDULE, OPERATING HOURS / START COUNTER, PRINT, SERVICE, and HISTORY menu keys. The menus activated by each of these buttons can only be viewed after an acceptable password is entered. Each parameter is associated with a level of access. Each level of access is associated with a specific password. The access levels available are: Level 1 or Level 2.

- If a parameter is tagged as Level 1, password of 9675 must be entered in order to change the value.
- If a parameter is tagged as Level 2, a password of 9725 must be entered in order to change the value. Entering the Level 2 password will also allow the changing of a Level 1 parameter.

Pressing SETPOINTS, PROGRAM, OPTIONS, DATE/TIME, SCHEDULE, OPERATING HOURS / START COUNTER, PRINT, SERVICE, or HISTORY key will take the user to the login prompt. When the user is first presented with the login prompt, the password field will be blank. If the user wishes to change Level 1 or Level 2 parameters, the user must know the appropriate password. At that point, only the parameters changeable under the specific password level will be displayed. For example, if the user presses the Options menu key, and then enters a Level 1 password, the user will be presented with a list of option parameters that have been tagged as Level 1. If the user enters a level 2 password, all parameters are displayed.

The password is entered by pressing the correct sequence of numerical keys (the 0 key through the 9 key), then pressing the ✓ key. As digits are entered, asterisks will be placed in the password field. Once entered, the menu system will compare the password to a list of stored passwords. If the entered password matches one of the stored passwords, the user is allowed access at the specified level, and the display will show the first applicable parameter of the menu list, with the appropriate edit prompts. If the password is not correct, the screen will display “Password Incorrect” for two seconds and then revert back to the Login Prompt. Pressing the X key during password entry will cancel the password entry process and take the user back to the Login Prompt.

Once a password has been accepted, reentry of that password will not be required until either the user presses a menu key other than SETPOINTS, PROGRAM, OPTIONS, DATE/TIME, SCHEDULE, OPERATING HOURS / START COUNTER, PRINT, SERVICE, HISTORY or key activity is idle for fifteen minutes. This ensures that the menu system reverts to password protection within an acceptable timeout.

## POWER UP BANNER

When power is first applied to the control panel, the following message will be displayed for two seconds:

The top line displays the copyright message. The bottom line displays the software version, and the present date and time.

The software version number will be in the following formats:

- C.ECO.ZZ.YY (control board released version)
- Where C is the Product Classification and stands for Commercial unit
- ECO is the Family Code and stands for YPAL Packaged Rooftop Air Conditioner Control Panel
- ZZ = the Product Code
- YY = the Version Number

## COMMUNICATION

The Unit Controller is designed to communicate with a Building Automation System and a printer.

The Building Automation System communication uses BACnet protocol, MS/TP, Modbus I/O, Modbus Server, Modbus Client or Terminal. Other Building Automation system networks can be connected by using a router.

The printer communication uses ASCII protocol and RS-232 hardware.

## Communication Ports

The IPU Control board has four serial communication ports. BACnet MS/TP must use Port 1 and Terminal must use Port 2, which is the RS232 Port. Other protocols may be selected on Ports 3 or 4.

## BACnet Wiring

All BACnet devices are “daisy chained” together using a twisted pair, the (+) is connected to the (+) and the (-) to the (-). Do not connect wiring to terminals 1, 2 or 5. The connections on the PORT 1 connector are as follows:

- 1 - 5V
- 2 - Ground
- 3 - Receive (-)
- 4 - Transmit (+)
- 5 - Open

## Device Object Instance (DE)

The unit is shipped to automatically establish the DE address after the MAC address is established using the MAC address switches ON the IPU or through the User Interface. The default Device Object Instance (DE) would be 23000 plus the MAC address. For example, If you had a MAC address of 10 the default Object Instance (DE) would be 23010.

The MAC address can be set in two ways using the MAC Address Switches ON the IPU or through the SERVICE key of the User Interface. The 8-way binary switch uses seven of the rockers to set the MAC address. The network address must be between 1 and 127. To determine the node address, add the value of each DIP switch in the ON position as shown in *Figure 39 on page 131*. Switch 8 must always be in the ON position to allow terminal operation.

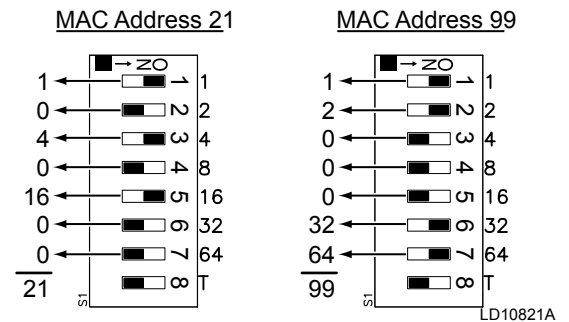

FIGURE 40 - MAC ADDRESS SWITCHES

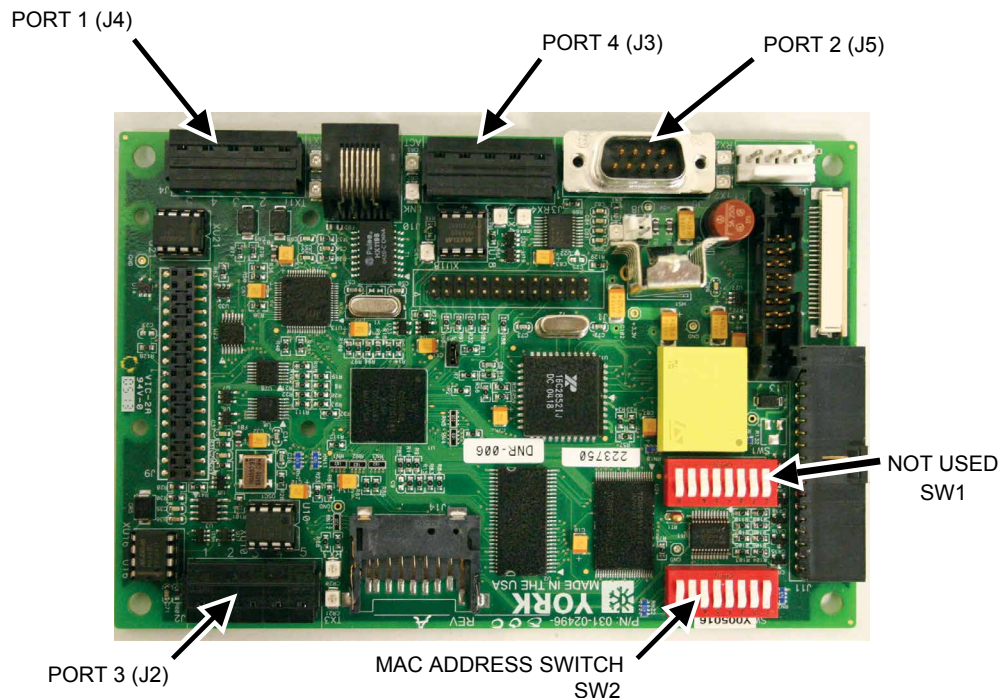

FIGURE 39 - IPU CONTROL BOARD

LD11197C

As stated above the MAC address can also be set using the SERVICE key. Go to parameter “PI MANUAL MAC ACCESS”. Press the ✓ key and enter the MAC address number using the numeric keypad and then press the ✓ key again. The MAC address can be a number from 0 to 127. If the MAC address is entered using the User Interface the control will ignore any values entered through the MAC Address Switches. In order to make the MAC Address switches active again a value of –1 would need to be entered for the “PI MANUAL MAC ACCESS”. In order to use the above procedure to establish the Device Object Instance (DE) the value for “DE MODIFIER OFFSET” MUST BE SET TO –1.”

In most applications the above procedure allows the Device Object Instance (DE) to be established. Some applications may request that the Device Object Instance (DE) be set to a given value. This can be done through the User Interface. To do this you would use the “DE MODIFIER ADDRESS” in conjunction with the “DE MODIFIER OFFSET”. Using this feature the Device Object Instance (DE) would be the (“DE MODIFIER ADDRESS” X 100) plus “DE MODIFIER OFFSET”. For example if you wanted a DE address of 2010 the “DE MODIFIER ADDRESS” to 20 and the “DE MODIFIER OFFSET” to 10. The Device Object instance (DE) is limited to a value between 0 and 4,194,303.

The “DE MODIFIER ADDRESS” and the “DE MODIFIER OFFSET” are both set using the SERVICE key of the User Interface. Go to parameter “DE MODIFIER ADDRESS”. Press the ✓ key to enter the DE Modifier Address number using the numeric keypad and then press the ✓ key again. Then go to parameter “DE MODIFIER OFFSET”. Press the ✓ key to enter the DE Modifier Offset number using the numeric keypad and then press the ✓ key again.

## Additional Settings

The following parameters can also be programmed using the SERVICE key:

### PORT 1

“P1 BAUD RATE”

“P1 MANUAL MAC ADDRESS”

“P1 PARITY”

“P1 PROTOCOL”

“P1 STOP BITS”

### PORT 2

“P2 BAUD RATE”

“P2 MANUAL MAC ADDRESS”

“P2 PARITY”

“P2 PROTOCOL”

“P2 STOP BITS”

### PORT 3

“P3 BAUD RATE”

“P3 MANUAL MAC ADDRESS”

“P3 PARITY”

“P3 PROTOCOL”

“P3 STOP BITS”

### PORT 4

“P4 BAUD RATE”

“P4 MANUAL MAC ADDRESS”

“P4 PARITY”

“P4 PROTOCOL”

“P4 STOP BITS”

Table 37 on page 133 gives the BACnet name, BACnet Object Type and Instance, and the Modbus Register Address for the available communication points.



**Any time a change is made to the MAC address using the DIP switches or a change to the above communication parameters using the SERVICE key of the User Interface the main power to the unit must be cycled OFF and back ON to change the value in memory.**

**TABLE 37 - BACNET MS/TP, MODBUS, BACNET IP**

BACNET NAME	USER INTERFACE NAME	READ/ WRITE	BACNET OBJECT TYPE AND INSTANCE	MODBUS REGISTER ADDRESS	POINTS LIST DESCRIPTION
ACT_DSP_SP	Duct Static Press Active Sp	R	AI01	514	Displays The Active Duct Static Press Sp ("W.C.)
ACT_MIN_FLOW	Active Minimum Airflow	R	AI02	515	Displays The Min Ventilation Air (CFM) Sp When The Unit Has An Air Flow Monitoring Station
ACT_MIN_POS	Active Minimum Position	R	AI03	516	Displays The Min OA Damper Position (%) When The Unit Is Fixed Min Vent Control
ACT_SAT_SP	Active Supply Air Temp Sp	R	AI04	517	Displays The Active Supply Air Temp Sp
ACT_SLAB_CTL	Active Slab Control (Flexsys Only)	R/W	AV77 BV01	1102	Allows The Active Slab Control To Be Turned On/Off 0=Off 1=On
AMORN_WA_ACT	Adaptive Morning Warmup Status (Only Used With Internal Time Clock)	R	BI01		Displays The Status Of The Adaptive Morning Warm-Up
BLD_STAT_PRS	Building Pressure Current	R	AI05	518	Displays The Current Building Press ("W.C.)
BULD_PRES_SP	Bldg Press Sp	R/W	AV01	1026	Displays The Active Building Pressure Sp ("W.C.)
BYPASS_DAMPER	Bypass Damper Position (Flexsys Only)	R	AI06	519	Displays The Actual Bypass Damper Position (%)
CO2_1_OUT	CO <sub>2</sub> Level Of The Outside Air	R	AI07	520	Displays The Actual OA Air CO <sub>2</sub> (PPM)
CO2_2_IN	CO <sub>2</sub> Level Of The Inside Air	R	AI08	521	Displays The Actual RA Air CO <sub>2</sub> (PPM)
CO2_INSIDE	CO <sub>2</sub> LVL Inside Value BAS	R/W	AV43	1168	A BAS Entered Value For The Inside CO <sub>2</sub> Level. "CO <sub>2</sub> LVL Inside BAS" Must Be Enabled Using The Service Key In Order To Use This Point (CO <sub>2</sub> )
CO2_OFFSET	CO <sub>2</sub> Offset Sp	R/W	AV02	1027	Displays The Value (PPM) That The Indoor CO <sub>2</sub> Must Rise Above The Outside CO <sub>2</sub> To Activate Demand Ventilation
COL/HEAT_FLT	Cooling/Heating Fault Status	R	BI02	1283	Displays The Status Of The Cooling Or Heating System. 0=No Fault 1=Fault
COMFORT_VENT	Comfort Ventilation (Constant Volume)	R/W	AV78 BV02	1103	Displays The Status Of The Comfort Vent Option And Allow It To Be Turned On/Off: 0=Off 1=On
COMP_1A	Compressor 1A Status	R	BI03	1284	Displays The Status Of Comp 1A: 0=Off 1=On
COMP_1A_OPER	Comp 1A Operating Hrs	R	AI09	522	Displays The Operating Hrs Of Comp 1A
COMP_1B	Compressor 1B Status	R	BI04	1285	Displays The Status Of Comp 1B: 0=Off 1-On
COMP_1B_OPER	Comp 1B Operating Hrs	R	AI10	523	Displays The Operating Hrs Of Comp 1B

6

**TABLE 37 – BACNET MS/TP, MODBUS, BACNET IP (SEE NOTES AT END OF TABLE) (CONT'D)**

BACNET NAME	USER INTERFACE NAME	READ/ WRITE	BACNET OBJECT TYPE AND INSTANCE	MODBUS REGISTER ADDRESS	POINTS LIST DESCRIPTION
COMP_2A	Compressor 2A Status	R	BI05	1286	Displays The Status Of Comp 2A: 0=Off 1=On
COMP_2A_OPER	Comp 2A Operating Hrs	R	AI11	524	Displays The Operating Hrs Of Comp 2A
COMP_2B	Compressor 2B Status	R	BI06	1287	Displays The Status Of Comp 2B: 0=Off 1=On
COMP_2B_OPER	Comp 2B Operating Hrs	R	AI12	525	Displays The Operating Hrs Of Comp 2B
COMP_3A	Compressor 3A Status (70-150 Ton Only)	R	BI07	1288	Displays The Status Of Comp 3A: 0=Off 1=On
COMP_3A_OPER	Comp 3A Operating Hrs (70-150 Ton Only)	R	AI13	526	Displays The Operating Hrs Of Comp 3A
COMP_3B	Compressor 3B Status (70-150 Ton Only)	R	BI08	1289	Displays The Status Of Comp 3B: 0=Off 1=On
COMP_3B_OPER	Comp 3B Operating Hrs (70-150 Ton Only)	R	AI14	527	Displays The Operating Hrs Of Comp 3B
COMP_LPCO_1	Safety Input LPCO Ckt 1 Status	R	BI09	1290	Displays The Status Of The Low Press Switch On Ckt 1: 0=Fault 1=No Fault
COMP_LPCO_2	Safety Input LPCO Ckt 2 Status	R	BI10	1291	Displays The Status Of The Low Press Switch On Ckt 2: 0=Fault 1=No Fault
COMP_LPCO_3	Safety Input LPCO Ckt 3 Status (70-150 Ton Only)	R	BI11	1292	Displays The Status Of The Low Press Switch On Ckt 3: 0=Fault 1=No Fault
COMP_STAT_1	Safety Chain Ckt 1 Status	R	BI12	1293	Displays The Status Of Ckt 1 Safety Chain: 0=Fault 1=No Fault
COMP_STAT_2	Safety Chain Ckt 2 Status	R	BI13	1294	Displays The Status Of Ckt 2 Safety Chain: 0=Fault 1=No Fault
COMP_STAT_3	Safety Chain Ckt 3 Status (70-150 Ton Only)	R	BI14	1295	Displays The Status Of Ckt 3 Safety Chain: 0=Fault 1=No Fault
COND_FAN_1A	Cond Fan 1A/1 Status	R	BI15	1296	Displays The Status Of Cond Fan 1A/1: 0=Off 1=On
COND_FAN_1B	Cond Fan 1B/2 Status	R	BI16	1297	Displays The Status Of Cond Fan 1B/2: 0=Off 1=On
COND_FAN_2A	Cond Fan 2A/3 Status	R	BI17	1298	Displays The Status Of Cond Fan 2A/3: 0=Off 1=On
COND_FAN_2B	Cond Fan 2B/4 Status	R	BI18	1299	Displays The Status Of Cond Fan 2B/4: 0=Off 1=On
COND_FAN_3A	Cond Fan 3A/5 Status (70-150 Ton Only)	R	BI19	1300	Displays The Status Of Cond Fan 3A/5: 0=Off 1=On

**TABLE 37 – BACNET MS/TP, MODBUS, BACNET IP (SEE NOTES AT END OF TABLE) (CONT'D)**

BACNET NAME	USER INTERFACE NAME	READ/ WRITE	BACNET OBJECT TYPE AND INSTANCE	MODBUS REGISTER ADDRESS	POINTS LIST DESCRIPTION
<b>COND_FAN_3B</b>	Cond Fan 3B/6 Status (70-150 Ton Only)	R	BI20	1301	Displays The Status Of Cond Fan 3B/6: 0=Off 1=On
<b>COND_FAN_SPD</b>	Cond Fan Speed	R	AI15	528	Not Used At This Time. For Future Use
<b>CONTINU_VENT</b>	Continuous Ventilation (Constant Volume)	R/W	AV79 BV03	1104	Displays The Status Of The Continuous Ventilation Option And Allows For It To Be Turned On/Off: 0=Off 1=On
<b>DCT_ST_PR_RT</b>	Duct Static Press Reset	R	AI16	529	Displays The Status Of The Hardwired Duct Static Reset Value To Ctb1 (%)
<b>DCT_STAT_PRS</b>	Duct Static Press Current (VAV Or Flexsys)	R	AI17	530	Displays The Actual Duct Static Press. ("W.C.")
<b>DEW_PNT_RST</b>	Dew Point Reset (Flexsys)	R/W	AV80 BV04	1105	Allows The Dew Point Reset Feature To Be Turned On/Off: 0=Off 1=On
<b>DSP_HI_LIMIT</b>	Duct Static Reset High Sp (VAV Or Flexsys)	R/W	AV03	1028	Displays The Duct Static High Sp ("W.C.")
<b>DSP_LO_LIMIT</b>	Duct Static Reset Low Sp (VAV Or Flexsys)	R/W	AV04	1029	Displays The Duct Static Low Sp ("W.C.")
<b>DSP_RST_BAS</b>	Duct Static Press Reset BAS (VAV Or Flexsys)	R/W	AV05	1030	A BAS Value That Causes The Reset Of The Duct Static Press Sp Between To High And Low Values. "Duct Pres RST BAS" Must Be Enabled Thru The Service Key To Use This Point (%)
<b>ECON_ME_USED</b>	Econ Method Active	R	AI18	531	Displays The Status Of The Active Economizer Mode: 1=Dry Bulb 2=Single Enthalpy 3=Dual Enthalpy 4=Best Method Avail
<b>ECON_STATUS</b>	Econ System Status	R	AI19	532	Displays The Status Of The Economizer: 1=Installed And Active 2=Not Installed 3=Disabled
<b>ECONO_INSTAL</b>	Economizer System	R/W	AV81 BV05	1106	Allows The Economizer Feature To Be Turned On/Off: 0=Off 1=On
<b>ECONO_METHOD</b>	Econ Method To Use	R/W	AV06	1031	Allows For The Selection Of The Economizer Method To Use: 1=Dry Bulb 2=Single Enthalpy 3=Dual Enthalpy 4=Best Method Avail
<b>EL_AIR_TMP_H</b>	Evap Leaving Air Temp High Sp (Flexsys)	R/W	AV07	1032	Displays The Active Sp For The High Evap Leaving Air Temp. This Is The Sp The Compressors Are Controlled To (OCC Cooling W/ Bypass)
<b>EL_AIR_TMP_L</b>	Evap Leaving Air Temp Low Sp (Flexsys)	R/W	AV08	1033	Displays The Active Sp For The Low Evap Leaving Air Temp. This Is The Sp The Compressors Are Controlled To (OCC Cooling W/ Bypass)

**6**

**TABLE 37 – BACNET MS/TP, MODBUS, BACNET IP (SEE NOTES AT END OF TABLE) (CONT'D)**

BACNET NAME	USER INTERFACE NAME	READ/ WRITE	BACNET OBJECT TYPE AND INSTANCE	MODBUS REGISTER ADDRESS	POINTS LIST DESCRIPTION
EVAP_AIR_TMP	Flexsys Evap Temp Current (Flexsys)	R	AI20	533	Displays The Actual Temp Of The Air Leaving The Evaporator (OCC Cooling W/ Bypass)
EXH_DAMPER/VFD	Exhaust Damper BAS Control	R/W	AV52	NA*	Allows for the control of the Exhaust Fan Speed or Modulating Damper (Return Fan). 0 To 100% for both applications.
EXH_FAN_STAT	Exhaust Fan Status	R	BI21	1302	Displays The Status Of The Exhaust Fan Proving Circuit: 0=Open 1=Closed
EXHAUST_FAN	Exhaust Fan Output Status	R	BI22	1303	Displays The Status Of The Exhaust Fan Output: 0=Off 1=On
EXHAUST_OUT	Exhaust Damper Position	R	AI21	534	Displays The Control Output To The Exh Damper (%)
FAN_FAULT	Fan Fault Status	R	BI23	1304	Displays The Status Of The Supply, Exhaust Or Return Fan Fault: 0=No Fault 1=Fault
FAN_G	Fan (G) Status	R	BI24	1305	Displays The Status Of The Fan (G) Input; Either Hardwired (Ctb1) Or Communicated (BAS): 0=Off 1=On
FAN_G_BAS	Fan (G) BAS	R/W	AV82 BV06	1107	A BAS Command That Allows The Fan (G) Input To Be Turned On/Off: 0=Off 1=On
FILTER_STATS	Filter Status	R	BI25	1306	Displays The Status Of The Dirty Filter Input: 0=No Fault 1=Fault
FURN_OUT_1	Elect Heat Stage 1 Status Staged Gas Furn 1 Lo Status Mod Gas Furn 1A Low Status	R	BI26	1307	Displays The Status Of The Control Output To The Indicated Heat Section: 0=Off 1=On
FURN_OUT_2	Elect Heat Stage 2 Status Staged Gas Furn 1 High Status Mod Gas Furn 1A High Status	R	BI27	1308	Displays The Status Of The Control Output To The Indicated Heat Section: 0=Off 1=On
FURN_OUT_3	Elect Heat Stage 3 Status Staged Gas Furn 2 Low Status Mod Gas Furn 2 Low Status	R	BI28	1309	Displays The Status Of The Control Output To The Indicated Heat Section: 0=Off 1=On
FURN_OUT_4	Elect Heat Stage 4 Status Staged Gas Furn 2 High Status Mod Gas Furn 2 High Status	R	BI29	1310	Displays The Status Of The Control Output To The Indicated Heat Section: 0=Off 1=On
FURN_OUT_5	Elect Heat Stage 5 Status Staged Gas Furn 3 Low Status Mod Gas Furn 3 Low Status	R	BI30	1311	Displays The Status Of The Control Output To The Indicated Heat Section: 0=Off 1=On

\*Not Available



**TABLE 37 – BACNET MS/TP, MODBUS, BACNET IP (SEE NOTES AT END OF TABLE) (CONT'D)**

BACNET NAME	USER INTERFACE NAME	READ/ WRITE	BACNET OBJECT TYPE AND INSTANCE	MODBUS REGISTER ADDRESS	POINTS LIST DESCRIPTION
FURN_OUT_6	Elect Heat Stage 6 Status Staged Gas Furn 3 High Status Mod Gas Furn 3 High Status	R	BI31	1312	Displays The Status Of The Control Output To The Indicated Heat Section: 0=Off 1=On
FURN_OUT_7	Elect Heat Stage 7 Status Mod Gas Furn 1B Status	R	BI32	1313	Displays The Status Of The Control Output To The Indicated Heat Section: 0=Off 1=On
HEAT_ENABLE	Heating System	R/W	AV83 BV07	1108	A BAS Command That Allows The Heating Function To Be Turned On/Off: 0=Enabled 1=Disabled
HEAT_ENT_TEMP	Heat Entering Temp	R	AI22	535	Displays The Actual Temp Of The Air Entering The Elect, Staged Gas, Or Mod Gas Heat Sections
HEAT_STAGES	Electric Heat Stages Or Gas Heat Stages	R	AI23	536	Displays The Number Of Elect Or Staged Gas Heat Stages Available
HEAT_VACTION	Hw Valve Action	R/W	AV84 BV08	1109	A BAS Command That Allows The Hot Water/Steam Valve Action To Be Changed: 0=Direct 1=Reverse
HEATING_SAT	Heating Suppy Sir Temp Sp (VAV Or Flexsys)	R/W	AV09	1034	Displays The Active Supply Air Temp Sp For Heating
HEATING_VLV	Heating Valve	R	AI24	537	Displays The Ouput From The Control To A Hw/Steam Valve Or Mod Gas Heat Valve (%)
HW_FRZ_STAT	Hw/Steam Coil Freezestat Status	R	BI33	1314	Displays The Status Of The Freezestat On Units With Hw/Steam Heat: 0=No Fault 1-Faulted
LOCAL_STOP	Local Stop Status	R	BI34	1315	Displays The Status Of The 24Vac Input To The Control Board Thru The Sd Terminal And/Or The Unit On/Off Switch
MAX_BYPASS	Maximum Bypass Sp (Flexsys)	R/W	AV10	1035	Displays The Max Setting For The Bypass Damper
MAX_FLOW_DV	Outside Air Max Flow Sp	R/W	AV11	1036	Displays The Max Airflow For Demand Ventilationwith An Airflow Station (CFM)
MECH_LCK_TMP	Mech Cooling Lockout Sp	R/W	AV12	1037	Displays The Min OA Temp At Which Mech Cooling Is Allowed To Operate
MIN_FLOW_DV	Outside Air Min Flow Sp	R/W	AV13	1038	Displays The Min Airflow For Demand Ventilation With An Airflow Station (CFM)
MIN_OA_FLO	Minimum OA Flow Set Point	R/W	AV51	1076	Displays The Min Outside Airflow Active Set Point For Tekair Measuring Station (Tekair Full IAQ). Ventilation Needs To Be User Enabled (CFM)
MIXD_SAT_LIM	Mx Supply Air Temp Sp (Flexsys)	R/W	AV14	1039	Displays The Active Mixed Air Temp Sp (OCC Cooling W/O Bypass-Compressor Control) (OCC Cooling W/ Bypass-Damper Control)

**TABLE 37 – BACNET MS/TP, MODBUS, BACNET IP (SEE NOTES AT END OF TABLE) (CONT'D)**

BACNET NAME	USER INTERFACE NAME	READ/ WRITE	BACNET OBJECT TYPE AND INSTANCE	MODBUS REGISTER ADDRESS	POINTS LIST DESCRIPTION
MORN_WARM_UP	Morning Warm Up	R/W	AV85 BV09	1110	A BAS Command That Allows Morning Warm-Up To Be Enabled/Disabled: 0=Enabled 1-Disabled
MORN_WUP_CMD	Morn Warmup Command	R/W	AV86 BV10	1111	A BAS Command That Starts/Stops Morning Warm-Up: 0=Off 1=On
MORN_WUP_RAT	Heating Ret Air Temp Sp (VAV Or Flexsys)	R/W	AV15	1040	Displays The Active R/A Temp Sp For Heating
NIGHT_SETBAC	Night Setback For Heating	R/W	AV87 BV11	1112	A BAS Command That Allows Night Set Back To Be Turned On/Off: 0=Off 1=On
OA_DAMP_POS1	OA Damper Minimum Position	R/W	AV16	1041	Displays The Active Sp For The Min OA Damper When Using Fixed Minimum Ventilation And The Supply Fan VFD Is At 100%
OA_DAMP_POS2	OA Damper Maximum Position	R/W	AV17	1042	Displays The Max Position For The OA Damper When Using Fixed Minimum Ventilation And The Supply Fan VFD Is At 50%
OA_DAMPER	OA Damper Position Current	R	AI25	538	Displays The Position Of The OA Damper (%)
OA_ENTH_LIMIT	OA Enthalpy Sp	R/W	AV18	1043	Displays The Max Enthalpy Sp For Using OA For Cooling (Btu/Lb) Single Or Dual Enthalpy
OA_ENTHALPY	OA Enthalpy	R	AI26	539	Displays The Current OA Enthalpy (Btu/Lb)
OA_FLO_PRS_1	OA Flow Press 1	R	AI27	540	Not Used
OA_FLO_PRS_2	OA Flow Press 2	R	AI28	541	Not Used
OA_FLOW_1	Iaq Damper Air Flows OA Flow 1	R	AI61	574	Displays The Air Flow Thru A Tek-Air Full Iaq Air Measuring Station (CFM)
OA_FLOW_2	Iaq Damper Air Flows OA Flow 2	R	AI62	575	Not Used
OA_FLOW_TOTL	OA Flow Total	R	AI63	576	Displays The Total Air Flow Thru A Tek-Air Full Iaq Air Measuring Station (CFM)
OA_REL_HUMID	OA Humidity	R	AI29	542	Displays The Current OA Relative Humidity (%)
OA_TEMP	OA Temperature	R	AI30	543	Displays The Current OA Temp
OAT_HIGH_SAT	OA Temp Sp For Hi Supply Air Temp (VAV, And Only If Sat Reset Method Is Outside Air)	R/W	AV19	1044	Displays The OA Temp Sp Used For Switching To The High Supply Air Temp Sp

**TABLE 37 – BACNET MS/TP, MODBUS, BACNET IP (SEE NOTES AT END OF TABLE) (CONT'D)**

BACNET NAME	USER INTERFACE NAME	READ/ WRITE	BACNET OBJECT TYPE AND INSTANCE	MODBUS REGISTER ADDRESS	POINTS LIST DESCRIPTION
OAT_LOW_SAT	OA Temp Sp For Lo Supply Air Temp (VAV, And Only If Sat Rest Method Is Outside Air)	R/W	AV20	1045	Displays The OA Temp Sp Used For Switching To The Low Supply Air Temp Sp
OCC_MODE	Occupancy Mode Status	R	BI35	1316	Displays The OCC/UNOCC Status With Hardwired, Communicated, Or Internal Clock Schedule Input: (Ena=Enabled/OCC Dis=Disabled/UNOCC)
OCC_STATE	Occupancy State Status	R	BI36	1317	Displays The Status Of The Hardwired Input: (Ena=Enabled/OCC Dis=Disabled/UNOCC)
OCC_ZN_COOL	OCC Zone Cooling Sp	R/W	AV21	1046	Displays The Active Occupied Zone Cooling Sp
OCC_ZN_HEAT	OCC Zone Heating Sp	R/W	AV22	1047	Displays The Active Occupied Zone Heating Sp
OCCUPNCY_CMD	Occupancy Command	R/W	AV88 BV12	1113	A BAS Command That Allows The Unit To Be Placed In The OCC/UNOCC Mode: (0=UNOCC 1=OCC)
PRS_1_DISCH	Disch Press Ckt 1	R	AI31	544	Displays The Current Disch Press Of Ckt 1 (Psig)
PRS_1_SUCT	Suct Press Ckt 1	R	AI32	545	Displays The Current Suct Press Of Ckt 1 (Psig)
PRS_2_DISCH	Disch Press Ckt 2	R	AI33	546	Displays The Current Disch Press Of Ckt 2 (Psig)
PRS_2_SUCTION	Suct Press Ckt 2	R	AI34	547	Displays The Current Suct Press Of Ckt 2 (Psig)
PRS_3_DISCH	Disch Press Ckt 3 (70-150 Ton Only)	R	AI35	548	Displays The Current Disch Press Of Ckt 3 (Psig)
PRS_3_SUCT	Suct Press Ckt 3 (70-150 Ton Only)	R	AI36	549	Displays The Current Suct Press Of Ckt 3 (Psig)
PUMP_DOWN	Pump Down	R/W	AV89 BV13	1114	A BAS Command That Allows The Pump Down Feature To Be Turned On/Off: (0=On 1=Off)
PUMP_DOWN_1	Pump Down Llsv 1 Status	R	BI37	1318	Displays The Status Of The Output To The Ckt 1 Liq Line Solenoid Vlv: (0=On 1=Off)
PUMP_DOWN_2	Pump Down Llsv 2 Status	R	BI38	1319	Displays The Status Of The Output To The Ckt 2 Liq Line Solenoid Vlv: (0=On 1=Off)
PUMP_DOWN_3	Pump Down Llsv 3 Status (70-150 Ton Only)	R	BI39	1320	Displays The Status Of The Output To The Ckt 3 Liq Line Solenoid Vlv: (0=On 1=Off)
RA_DIFF_BAS	Return Air Diff Sp BAS (Flexsys)	R/W	AV42	1067	Displays The Active Temp Sp That Causes The Unit To Switch From Cooling W/O Bypass To Cooling W/Bypass
RAT_COOL_SP	Cooling Return Air Temp Sp (VAV Or Flexsys)	R/W	AV23	1048	Displays The Active Return Air Temp Sp For Cooling

**TABLE 37 – BACNET MS/TP, MODBUS, BACNET IP (SEE NOTES AT END OF TABLE) (CONT'D)**

BACNET NAME	USER INTERFACE NAME	READ/ WRITE	BACNET OBJECT TYPE AND INSTANCE	MODBUS REGISTER ADDRESS	POINTS LIST DESCRIPTION
RAT_HIGH_SAT	Ra Temp Sp For Hi Supply Air Temp (VAV, And Only If Sat Reset Method Is Return Air)	R/W	AV24	1049	Displays The Ra Temp Sp Used For Switching To The High Supply Air Temp Sp
RAT_LOW_SAT	Ra Temp Sp For Lo Supply Air Temp (VAV, And Only If Sat Reset Method Is Return Air)	R/W	AV25	1050	Displays The Ra Temp Sp Used For Switching To The Low Supply Air Temp Sp
RDY_RUN_C1A	Ready To Run Comp 1A Status	R	BI40	1321	Displays The Status Of Comp 1A Ready To Run If Comp Is Off: (Yes/No)
RDY_RUN_C1B	Ready To Run Comp 1B Status	R	BI41	1322	Displays The Status Of Comp 1B Ready To Run If The Comp Is Off: (Yes/No)
RDY_RUN_C2A	Ready To Run Comp 2A Status	R	BI42	1323	Displays The Status Of Comp 2A Ready To Run If The Comp Is Off: (Yes/No)
RDY_RUN_C2B	Ready To Run Comp 2B Status	R	BI43	1324	Displays The Status Of Comp 2B Ready To Run If The Comp Is Off: (Yes/No)
RDY_RUN_C3A	Ready To Run Comp 3A Status (70-150 Ton Only)	R	BI44	1325	Displays The Status Of Comp 3A Ready To Run If The Comp Is Off: (Yes/No)
RDY_RUN_C3B	Ready To Run Comp 3B Status (70-150 Ton Only)	R	BI45	1326	Displays The Status Of Comp 3B Ready To Run If The Comp Is Off: (Yes/No)
RDY_STOP_C1A	Ready To Stop Comp 1A Status	R	BI46	1327	Displays The Status Of Comp 1A Ready To Stop If Operating: (Yes/No)
RDY_STOP_C1B	Ready To Stop Comp 1B Status	R	BI47	1328	Displays The Status Of Comp 1B Ready To Stop If Operating: (Yes/No)
RDY_STOP_C2A	Ready To Stop Comp 2A Status	R	BI48	1329	Displays The Status Of Comp 2A Ready To Stop If Operating: (Yes/No)
RDY_STOP_C2B	Ready To Stop Comp 2B Status	R	BI49	1330	Displays The Status Of Comp 2B Ready To Stop If Operating: (Yes/No)
RDY_STOP_C3A	Ready To Stop Comp 3A Status (70-150 Ton Only)	R	BI50	1331	Displays The Status Of Comp 3A Ready To Stop If Operating: (Yes/No)
RDY_STOP_C3B	Ready To Stop Comp 3B Status (70-150 Ton Only)	R	BI51	1332	Displays The Status Of Comp 3B Ready To Stop If Operating: (Yes/No)
RET_AIR_BY_S	Return Air Bypass Active Sp	R	AI37	550	Displays The Value (%) For The Current Sp Of The Ra Bypass Damper Onn A Flexsys Unit
RET_AIR_ENTH	Return Air Enthalpy	R	AI38	551	Displays The Actual Ra Enthalpy (Btu/Lb)
RET_AIR_HUMD	Return Air Humidity	R	AI39	552	Displays The Actual Ra Relative Humidity (%)
RET_AIR_TEMP	Return Air Temp Current	R	AI40	553	Displays The Actual Ra Temp (°F)

**TABLE 37 – BACNET MS/TP, MODBUS, BACNET IP (SEE NOTES AT END OF TABLE) (CONT'D)**

BACNET NAME	USER INTERFACE NAME	READ/ WRITE	BACNET OBJECT TYPE AND INSTANCE	MODBUS REGISTER ADDRESS	POINTS LIST DESCRIPTION
RET_FAN_OUT	Exhaust/Return Fan VFD	R	AI41	554	Displays The Output From The Control To The Exh Or Ret Fan VFD (%)
RET_FAN_PRES	Return Fan Pressure Current	R	AI42	555	Displays The Actual Pressure That Is Used To Control The Return Fan Speed ("W.C.)
RET_FAN_STAT	Return Fan Status	R	BI52	1333	Displays The Status Of The Return Fan Run Verification Circuit (0=Stop/Verification Ckt Open, 1=Run/Verification Ckt Closed)
RST_ENT_BAS	Reset Enthalpy Sp BAS	R/W	AV41	1066	Displays The Ra Enthalpy Sp Which Causes The Unit To Switch From The Evap Leaving High Sp To The Evap Leaving Low Sp
SAT_HIGH_LIM	Suppy Air Temp Hi Sp	R/W	AV26	1051	Displays The Upper Limit For The Supply Air Temp Sp On A VAV Unit (°F)
SAT_LOW_LIM	Supply Air Temp Lo Sp	R/W	AV27	1052	Displays The Lower Limit For The Supply Air Temp Sp On A VAV Unit (°F)
SAT_RST_BAS	Supply Air Temp Reset BAS	R/W	AV28	1053	Displays The Analog Input From The BAS System That Allows The Reset Of Ther Active Supply Air Temp Sp. 0 Uses Sat High Sp Amd 5 Uses Sat Low Sp. "Sat RST BAS" Must Be Enabled In The Service Menu For This Point To Function
SAT_SUC_TMP1	Saturated Suct Temp Ckt 1	R	AI43	556	Displays The Saturation Temp Of System 1 Suction Gas Based On System 1 Suction Press (°F)
SAT_SUC_TMP2	Saturated Suct Temp Ckt 2	R	AI44	557	Displays The Saturation Temp Of System 2 Suction Gas Based On System 2 Suction Press (°F)
SAT_SUC_TMP3	Saturated Suct Temp Ckt 3 (70-150 Ton Only)	R	AI45	558	Displays The Saturation Temp Of System 3 Suction Gas Based On System 3 Suction Press (°F)
SAT_TEMPER	Supply Air Tempering Status	R	BI53	1334	Displays The Status Of Supply Air Tempering (On/Off)
SEN/MSC_FLT	Sensor/Misc Fault Status	R	BI54	1335	Displays The Status Of A Sensor Or Misc Fault (0=No Fault 1=Faulted)
SF_PROV_SW	Supply Fan Status	R	BI55	1336	Displays The Status Of The Supply Fan Air Proving Circuit (0=Stop Verification/Ckt Open 1=Run Verification/Ckt Closed)
SF_SPD_H_SAT	Fan Speed Sp For Hi Supply Air Temp	R/W	AV29	1054	Displays The Supply Fan Speed Sp Used For Switching To The High Supply Air Temp Sp
SF_SPD_L_SAT	Fan Speed Sp For Lo Supply Air Temp	R/W	AV30	1055	Displays The Supply Fan Speed Sp Used For Switching To The Low Supply Air Temp Sp
SMOKE_PUR_1	Smoke Purge 1 Status	R	BI56	1337	Displays The Status Of The Smoke Purge 1 Input Either Hardwired Or Communicated (On/Off)

6

**TABLE 37 – BACNET MS/TP, MODBUS, BACNET IP (SEE NOTES AT END OF TABLE) (CONT'D)**

BACNET NAME	USER INTERFACE NAME	READ/ WRITE	BACNET OBJECT TYPE AND INSTANCE	MODBUS REGISTER ADDRESS	POINTS LIST DESCRIPTION
<b>SMOKE_PUR_2</b>	Smoke Purge 2 Status	R	BI57	1338	Displays The Status Of The Smoke Purge 2 Input Either Hardwired Or Communicated (On/Off)
<b>SMOKE_PUR_3</b>	Smoke Purge 3 Status	R	BI58	1339	Displays The Status Of The Smoke Purge 3 Input Either Hardwired Or Communicated (On/Off)
<b>SMOKE_PUR1_B</b>	Smoke Purge 1 BAS	R/W	AV90 BV14	1115	A BAS Command That Allows Smoke Purge 1 To Be Activated (0=Off 1=On)
<b>SMOKE_PUR2_B</b>	Smoke Purge 2 BAS	R/W	AV91 BV15	1116	A BAS Command That Allows Smoke Purge 2 To Be Activated (0=Off 1=On)
<b>SMOKE_PUR3_B</b>	Smoke Purge 3 BAS	R/W	AV92 BV16	1117	A BAS Command That Allows Smoke Purge 3 To Be Activated (0=Off 1=On)
<b>STG_1_COOL</b>	1st Stage Cooling SP (CV/SZVAV)	R/W	AV31	1056	Displays The Active Supply Air Temp Sp For A 1St Stage Cooling Input (Y1)
<b>STG_1_HEAT</b>	1st Stage Heating SP (CV/SZVAV)	R/W	AV32	1057	Displays The Active Supply Air Temp Sp For A 1St Stage Heating Input (W1)
<b>STG_2_COOL</b>	2nd Stage Cooling SP (CV/SZVAV)	R/W	AV33	1058	Displays The Active Supply Air Temp Sp For A 2Nd Stage Cooling Input (Y2)
<b>STG_2_HEAT</b>	2nd Stage Heating SP (CV/SZVAV)	R/W	AV34	1059	Displays The Active Supply Air Temp Sp For A 2Nd Stage Heating Input (W2)
<b>SUP_AIR_TEMP</b>	Supply Air Temp Current	R	AI46	559	Displays The Actual Supply Air Temp. (°F)
<b>SUP_AIR_TRST</b>	Supply Air Temp Reset	R	AI47	560	Displays The Value, 0-5 VDC, Of A Hardwired Or Communicated Input That Will Be Used To Reset The Supply Air Temp Sp (VDC)
<b>SUP_FAN_VFD</b>	Supply Fan VFD Speed	R	AI48	561	Displays The Output From The Control To The Supply Fan VFD (%)
<b>SUPPLY_FAN</b>	Supply Fan Output Status	R	BI59	1340	Displays The Status Of The Output From The Controller To The Supply Fan Circuit (0=Off 1=On)
<b>SYSTEM_STOP</b>	System Stop	R/W	AV35	1060	Allows A BAS Command That Manually Shuts Down Compressor Circuits (0=All Ckts Can Operate 1=Shuts Down Ckt 1 2=Shuts Down Ckt 2 3=Shuts Down Ckt 3)
<b>SZ_MIN_VFD</b>	Single Zone Minimum VFD	R/W	AV53	NA*	Allows the minimum supply fan speed to be reset between 33% and 66% when using SZVAV.
<b>TEMP_1_SUUCT</b>	Suct Temp Ckt 1	R	AI49	562	Displays The Actual System 1 Suct Line Temp (°F)
<b>TEMP_1_SUPER</b>	Suct Superheat Ckt 1	R	AI50	563	Displays The System 1 Superheat (°F)
<b>TEMP_2_SUUCT</b>	Suct Temp Ckt 2	R	AI51	564	Displays The Actual System 2 Suct Line Temp (°F)
<b>TEMP_2_SUPER</b>	Suct Superheat Ckt 2	R	AI52	565	Displays The System 2 Superheat (°F)

\*Not Available

**TABLE 37 – BACNET MS/TP, MODBUS, BACNET IP (SEE NOTES AT END OF TABLE) (CONT'D)**

BACNET NAME	USER INTERFACE NAME	READ/ WRITE	BACNET OBJECT TYPE AND INSTANCE	MODBUS REGISTER ADDRESS	POINTS LIST DESCRIPTION
<b>TEMP_3_SUCT</b>	Suct Temp Ckt 3 (70-150 Ton Only)	R	AI53	566	Displays The Actual System 3 Suct Line Temp (°F)
<b>TEMP_3_SUPER</b>	Suct Superheat Ckt 3 (70-150 Ton Only)	R	AI54	567	Displays The System 3 Superheat (°F)
<b>UND_FLR_DEWP</b>	Underfloor Slab Dew Point (Flexsys)	R	AI55	568	Displays The Calculated Dew Point Of The Underfloor Air (°F)
<b>UND_FLR_HUMD</b>	Underfloor Air Humidity (Flexsys)	R	AI56	569	Displays The Humidity Value Of The Underfloor Air That The Unit Is Controlled To (°F)
<b>UND_FLR_TEMP</b>	Underfloor Slab Temp (Flexsys)	R	AI57	570	Displays The Temp Of The Underfloor Air That The Unit Is Contolling To (°F)
<b>UND_HUMD_BAS</b>	Underfloor Air Humidity BAS	R/W	AV36	1061	Allows The BAS System To Input An Underfloor Air Humidity Value To The Control. (%) "Under Flr Humi BAS" Must Be Enabled In The Service Menu For This Point To Function
<b>UND_TEMP_BAS</b>	Underfloor Slab Temp BAS	R/W	AV37	1062	Allows The BAS System To Input An Underfloor Air Temp Value To The Control (°F) "Under Flr Temp BAS" Must Be Enabled In The Service Menu For This Point To Function
<b>UNIT_MODE</b>	Current Oper Mode	R	AI58	571	Displays The Current Operating Mode: 0=OCC Cool 1=OCC Cool Low 2=OCC Cool High 3=OCC Cool W/ Byp 4=OCC Cool W/O Byp 5= OCC Heat 6=OCC Heat Low 7=OCC Heat High 8=OCC Standby 9=UNOCC Cool 10=UNOCC Cool Low 11=UNOCC Cool High 12=UNOCC Heat 13=UNOCC Heat Low 14=UNOCC Heat High 15=UNOCC Standby 16=Comfort Vent Cool 17=Comfort Vent Heat 18=Night Set-Back 19=Morning Warm-Up 20=Power Up Standby
<b>UNIT_STOP</b>	Unit Stop	R/W	AV93 V17	1118	A BAS Command That Allows The Unit To Be Shut Down (0=Normal Operation 1=Unit Stopped)
<b>UNSTABLE_SYS</b>	Unstable System Status (Not Used)	R	BI60		

**TABLE 37 – BACNET MS/TP, MODBUS, BACNET IP (SEE NOTES AT END OF TABLE) (CONT'D)**

BACNET NAME	USER INTERFACE NAME	READ/ WRITE	BACNET OBJECT TYPE AND INSTANCE	MODBUS REGISTER ADDRESS	POINTS LIST DESCRIPTION
UNOCC_ZN_COOL	UNOCC Zone Cooling Sp	R/W	AV38	1063	UNOCC Zone Cooling Sp
UNOCC_ZN_HEAT	UNOCC Zone Heating Sp	R/W	AV39	1064	UNOCC Zone Heating Sp
VAV_HEAT	VAV Heat Relay Status	R	BI61	1342	Displays The Status Of The Output That Energizes A VAV Heat Relay (Off/On)
VENT_CONTROL	Ventilation Control	R/W	AV94 BV18	1119	A BAS Command That Allows The Selection Of The Ventilation Function (0=Fixed Minimum 1=Demand)
VENT_DEM_OUT	Ventilation Demand	R	AI59	572	Displays The Status Of The Ventilation Output For Demand Ventilation (%)
VENT_ENABLE	Ventilation System	R/W	AV95 BV19	1120	A BAS Command That Allows The Ventilation Function To Be Turned On Or Off (0=Off 1=On)
W1_LO_HEAT_B	W1 Lo Heat BAS (CV Only)	R/W	AV96 BV20	1121	A BAS Command That Allows An Input For W1, First Stage Heat (0=Off 1=On)
W1_LOW_HEAT	W1 Low Heat Status	R	BI62	1343	Displays The Status Of The W1 Heat Input Either Hardwired Or Communicated From A BAS (On/Off)
W2_HI_HEAT_B	W2 High Heat BAS (CV Only)	R/W	AV97 BV21	1122	A BAS Command That Allows An Input For W2, Second Stage Heat (0=Off 1=On)
W2_HIGH_HEAT	W2 High Heat Status	R	BI63	1344	Displays The Status Of The W2 Heat Input Either Hardwired Or Communicated From A BAS (On/Off)
Y1_LO_COOL_B	Y1 Lo Cool BAS (CV Only)	R/W	AV98 BV22	1123	A BAS Command That Allows An Input For Y1, First Stage Cool (0=Off 1=On)
Y1_LOW_COOL	Y1 Low Cool Status	R	BI64	1345	Displays The Status Of The Y1 Cool Input Either Hardwired Or Communicated From A BAS (On/Off)
Y2_HI_COOL_B	Y2 High Cool BAS (CV Only)	R/W	AV99 BV23	1124	A BAS Command That Allows An Input For Y2, Second Stage Cool (0=Off 1=On)
Y2_HIGH_COOL	Y2 High Cool Status	R	BI65	1346	Displays The Status Of The Y2 Cool Input Either Hardwired Or Communicated From A BAS (On/Off)
ZONE_TEMP	Zone Temp Current	R	AI60	573	Displays The Actual Zone Temperature (°F)
ZONE_TEMP_BAS	Zone Temp BAS	R/W	AV40	1065	Allows The BAS System To Input An Zone Temperature Reading (°F) The Control Method Must Be Set To "Comm Zone Temp" For This Point To Function

**NOTES**

1. The most up to date listing of the Standard Points Mapping can be found on the JCI website
2. For a Building Automation System using Bacnet IP, a gateway must be used, since the unit controller does not have a Bacnet IP port. We recommend using a JCI NCE (MS-NCE2560-0)



**TABLE 38 - LON POINTS LIST**

BACNET NAME	USER INTERFACE NAME	BACNET OBJECT TYPE AND INSTANCE	SNVT	POINTS LIST DESCRIPTION
nvoACT_DSP_SP	Duct Static Setpoint	AI-001	SNVT_count_f (51)	A Derived Value The Duct Static Is Controlled To ("W.C.)
nvoACT_MIN_FLOW	Active Minimum Air Flow	AI-002	SNVT_count_f (51)	A Derived Value The Minimum Ventilation Air Is Controlled To (CFM)
nvoACT_MIN_POS	Active Minimum Position	AI-003	SNVT_switch (95)	A Derived Value The Damper Is Controlled To For Minimum Ventilation Air (%)
nvoACT_SAT_SP	Supply Air Setp	AI-004	SNVT_count_f (51)	A Derived Value The Supply Air Tempeprature Is Controlled To (°F)
nviACT_SLAB_CTL	Active Slab Control	AV-077	SNVT_switch (95)	Allows The Active Slab Control Feature To Be Turned On And Off On Flexsys Units (0 = Off / 1 = On)
nviBUILD_PRES_SP	Building Pressure Sp	AV-001	SNVT_count_f (51)	The Building Pressure Setpoint ("W.C.)
nvoBLD_STAT_PRS	Building Static Pres	AI-005	SNVT_count_f (51)	Actual Building Pressure Input ("W.C.)
nvoBYPASS_DAMPER	Bypass Damper	AI-006	SNVT_switch (95)	Actual Bypass Damper Position (%)
nvoCO2_1_OUT	CO <sub>2</sub> 1 (Outside)	AI-007	SNVT_count_f (51)	Actual Outdoor CO <sub>2</sub> Value (PPM)
nvoCO2_2_INSIDE	CO <sub>2</sub> 1 (Inside)	AI-008	SNVT_count_f (51)	Actual Indoor CO <sub>2</sub> Value (PPM)
nviCO2_OFFSET	CO <sub>2</sub> Offset	AV-002	SNVT_count_f (51)	The Difference Between The Indoor And Outside CO <sub>2</sub> Must Exceed This Value To Initiate Demand Ventilation (PPM)
nvoCOL_HEAT_FLT	Cooling/ Heating Fault	BI-002	SNVT_switch (95)	Gives The Fault Status Of The Cooling And Heating System (0 - Not Fault; 1 - Faulted)
nvoCOMP_1A	Compressor 1A	BI-003	SNVT_switch (95)	Status Of Compressor 1A, (On/Off)
nvoCOMP_1B	Compressor 1B	BI-004	SNVT_switch (95)	Status Of Compressor 1B, (On/Off)
nvoCOMP_2A	Compressor 2A	BI-005	SNVT_switch (95)	Status Of Compressor 2A, (On/Off)
nvoCOMP_2B	Compressor 2B	BI-006	SNVT_switch (95)	Status Of Compressor 2B, (On/Off)
nvoCOMP_3A	Compressor 3A (70-150 Ton Only)	BI-007	SNVT_switch (95)	Status Of Compressor 3A, (On/Off)
nvoCOMP_3B	Compressor 3B (70-150 Ton Only)	BI-008	SNVT_switch (95)	Status Of Compressor 3B, (On/Off)
nvoCOMP_LPCO_1	Compressor Lpco 1	BI-009	SNVT_switch (95)	Status Of Compressor System 1 Low Pressure Cutout Circuit (Nfl - No Fault / Flt - Faulted)
nvoCOMP_LPCO_2	Compressor Lpco 2	BI-010	SNVT_switch (95)	Status Of Compressor System 2 Low Pressure Cutout Circuit (Nfl - No Fault / Flt - Faulted)
nvoCOMP_LPCO_3	Compressor Lpco 3 (70-150 Ton Only)	BI-011	SNVT_switch (95)	Status Of Compressor System 3 Low Pressure Cutout Circuit (Nfl - No Fault / Flt - Faulted)

**6**

**TABLE 38– LON POINTS LIST (SEE NOTES AT END OF TABLE) (CONT'D)**

BACNET NAME	USER INTERFACE NAME	BACNET OBJECT TYPE AND INSTANCE	SNVT	POINTS LIST DESCRIPTION
nvoCOMP_STAT_1	Compressor Status 1	BI-012	SNVT_switch (95)	Status Of Compressor System 1 Compressor Safety Circuit (Nfl - No Fault / Flt - Faulted)
nvoCOMP_STAT_2	Compressor Status 2	BI-013	SNVT_switch (95)	Status Of Compressor System 2 Compressor Safety Circuit (Nfl - No Fault / Flt - Faulted)
nvoCOMP_STAT_3	Compressor Status 3 (70-150 Ton Only)	BI-014	SNVT_switch (95)	Status Of Compressor System 3 Compressor Safety Circuit (Nfl - No Fault / Flt - Faulted)
nvoDCT_ST_PR_RT	Duct Static Pres Rst	AI-016	SNVT_switch (95)	A Hardwired Entered Analog Voltage That Results In A %Reset Down From The Duct Static High Limit Based On A Percent Of The Difrference Between Duct Static High Limit And Duct Static Low Limit (%)
nvoDCT_STAT_PRS	Duct Static Pres	AI-017	SNVT_count_f (51)	Actual Duct Static Pressure Input To The Control ("WG)
nviDEW_PNT_RST	Dew Point Reset	AV-080	SNVT_switch (95)	This Allows The Dew Point Reset Feature To Be Turned On And Off On Flexsys Units (0 = Off / 1 = On)
nviDSP_HI_LIMIT	Duct Static High Limit	AV-003	SNVT_count_f (51)	The Duct Static Upper Setpoint ("WG)
nviDSP_LO_LIMIT	Duct Static Low Limit	AV-004	SNVT_count_f (51)	The Duct Static Lower Setpoint ("WG)
nviDSP_RST_BAS	Duct Static Pres RST BAS	AV-005	SNVT_switch (95)	A BAS Entered Value That Results In A %Reset Down From The Duct Static High Limit Based On A Percent Of The Difrference Between Duct Static High Limit And Duct Static Low Limit (%). "Duct Pres RST BAS" Must Be Enabled Using The Service Key In Order To Use This Feature
nviECONO_INSTAL	Economizer Installed	AV-081	SNVT_switch (95)	Allows The Economizer Feature To Be Turned On And Off (0 = Off / 1 = On)
nvoECON_ME_USED	Economizer Method	AI-018	SNVT_count (8)	The Economizer Method Being Used By The Control (1 - Dry Bulb; 2 - Single Enthalpy; 3 - Dual Enthalpy; 4 - Best Method)
nvoECON_STATUS	Economizer Suitable Econ Installed	AI-019	SNVT_count (8)	Status Of The Economizer Option (0 - Installed And Inactive; 1 - Installed And Active; 2 - Not Installed; 3 - Disabled)
nviEL_AIR_TMP_H	Evap Leaving Air Temp High	AV-007	SNVT_count_f (51)	On A Flexsys Unit With Bypass This Is The Supply Air Temperature High Setpoint (°F)
nviEL_AIR_TMP_L	Evap Leaving Air Temp Low	AV-008	SNVT_count_f (51)	On A Flexsys Unit With Bypass This Is The Supply Air Temperature Low Setpoint (°F)
nvoEVAP_AIR_TMP	Evaporator Air Temp 1	AI-020	SNVT_count_f (51)	Actual Temperature Of Air Leaving The Evaporator Coil On A Flexsys Unit (°F)
nvoEXHAUST_FAN	Exhaust Fan	BI-022	SNVT_switch (95)	The Status Of The Binary Output For The Exhaust ( On / Off)

**TABLE 38 – LON POINTS LIST (SEE NOTES AT END OF TABLE) (CONT'D)**

BACNET NAME	USER INTERFACE NAME	BACNET OBJECT TYPE AND INSTANCE	SNVT	POINTS LIST DESCRIPTION
nvoEXH_FAN_STAT	Exhaust Fan Status	BI-021	SNVT_switch (95)	The Status Of The Exhaust Fan Run Verification Circuit (Run - On Verification Circuit Closed / Sto - Stop - Verification Circuit Open)
nvoFAN_FAULT	Fan Fault	BI-023	SNVT_switch (95)	Identifies If There Is A Supply, Exhaust, Or Return Fan Fault (0 - No Fault; 1= Faulted)
nvoFILTER_STATS	Filter Status	BI-025	SNVT_switch (95)	Identifies The Status Of The Binary Dirty Filter Input (0- No Fault; 1- Faulted)
nvoHEAT_ENT_TMP	Heat Entering Temp	AI-022	SNVT_count_f (51)	Actual Temperature Of The Air Entering The Stagged Heat Section (°F)
nviHEATING_SAT	Heating Sat	AV-009	SNVT_count_f (51)	The Heating Sat Setpoint For A VAV Or Flexsys Unit (°F)
nvoHEAT_STAGES	Electric Heat Stages Gas Heat Stages	AI-023	SNVT_count (8)	Derived Value Showing The Number Of Electric Or Stagged Gas Heat Stages Available (1 - 7)
nvoHEATING_VALV	Heating Valve	AI-024	SNVT_switch (95)	The Oupuit From The Control To A Hot Water, Steam, Or Modulating Gas Heat Valve (%)
nvoHW_FRZ_STAT	Hot Water Frz Status	BI-033	SNVT_switch (95)	The Status Of The Freezestat Circuit On Units With Hot Water Or Steam Heat. (Flt - Faulted / Nfl - No Fault)
nviMAX_BYPASS	Maximum Bypass	AV-010	SNVT_switch (95)	The Maximum Allowable Setting For The By Pass Damper In A Flexsys Unit (%)
nviMAX_FLOW_DV	Max Flow Demand Ventilation	AV-011	SNVT_count_f (51)	The Maximum Allowable Airflow For Demand Ventilation With An Air Measuring Station (CFM)
nviMECH_LCK_TMP	Mech Clg Lockout Temp	AV-012	SNVT_count_f (51)	The Minimum Outdoor Temepature At Which Mechanical Cooling Is Allowed To Operate (°F)
nviMIN_FLOW_DV	Min Flow Demand Ventilation	AV-013	SNVT_count_f (51)	The Minimum Allowable Airflow For Demand Ventilation With An Air Measuring Station (CFM)
nviMIXD_SAT_LIM	Mixed Sat Limit	AV-014	SNVT_count_f (51)	On A Flexsys Unit This Is The Supply Air Setpoint When Operating Without A Bypass Damper (°F)
nviMORN_WUP_CMD	Morning Warm Up Cmnd	AV-086	SNVT_switch (95)	A BAS Generated Command To Allow The Morning Warm Up Feature To Be Turned On And Off (0 = Off / 1 = On)
nviMORN_WUP_RAT	Rat Heating Setp	AV-015	SNVT_count_f (51)	On A VAV Or Flexsys Unit This Is The Return Air Temperature Setpoint Used To Determine When The Unit Should Switch To The Heating Mode (°F)
nviNIGHT_SETBAC	Night Set Back (For Heating)	AV-077	SNVT_switch (95)	This Command Allows The Night Set Back Heating Fuction To Be Turned On And Off (0 = Off / 1 = On)
nvoOA_DAMPER	Oa Damper	AI-025	SNVT_switch (95)	This Is The Position Of The Outdoor Damper (%)

**TABLE 38 – LON POINTS LIST (SEE NOTES AT END OF TABLE) (CONT'D)**

BACNET NAME	USER INTERFACE NAME	BACNET OBJECT TYPE AND INSTANCE	SNVT	POINTS LIST DESCRIPTION
nviOA_DAMP_POS1	Oa Damper Min Position 1	AV-016	SNVT_switch (95)	The Minimum Position For The Outdoor Air Damper When Using Fixed Ventilation Control When The Supply Fan Is At Full Speed (%)
nviOA_DAMP_POS2	Oa Damper Min Position 2	AV-017	SNVT_switch (95)	The Minimum Position For The Outdoor Air Damper When Using Fixed Ventilation Control When The Supply Fan Is At 50% Of Full Speed (%)
nvoOA_ENTHALPY	Outside Air Enthalpy	AI-026	SNVT_count_f (51)	Actual Outside Air Enthalpy (Btu/Lb)
nviOA_ENTH_LIMT	Oa Enthalpy Limit	AV-018	SNVT_count_f (51)	The Upper Enthalpy Limit To Allow The Use Of Outdoor Air For Single Or Dual Enthalpy Economizer (Btu/Lb)
nvoOA_FLO_PRS_1	Oa Flow Pressure 1	AI-027	SNVT_count_f (51)	Not Used
nvoOA_FLO_PRS_2	Oa Flow Pressure 2	AI-028	SNVT_count_f (51)	Not Used
nvoOA_REL_HUMID	Outside Air Humidity	AI-029	SNVT_switch (95)	Actual Outdoor Air Relative Humidity (%)
nvoOA_TEMP	Outside Air Temp	AI-030	SNVT_count_f (51)	Actual Outdoor Air Temperature (°F)
nviOCCUPNCY_CMD	Occupancy Command	AV-088	SNVT_switch (95)	This BAS Command Allows The Unit To Be Placed In The Occupied Or Unoccupied Mode (0 = Unoccupied / 1 = Occupied)
nviOCC_ZN_COOL	Occupied Zone Cooling Setp	AV-021	SNVT_count_f (51)	The Occupied Zone Cooling Setpoint (°F)
nviOCC_ZN_HEAT	Occupied Zone Heating Setp	AV-022	SNVT_count_f (51)	The Occupied Zone Heating Setpoint (°F)
nvoPRS_1_DISCH	Pressures 1 Discharge	AI-031	SNVT_count_f (51)	Actual System 1 Discharge Pressure (Psig)
nvoPRS_1_SUCTION	Pressures 1 Suction	AI-032	SNVT_count_f (51)	Actual System 1 Suction Pressure (Psig)
nvoPRS_2_DISCH	Pressures 2 Discharge	AI-033	SNVT_count_f (51)	Actual System 2 Discharge Pressure (Psig)
nvoPRS_2_SUCTION	Pressures 2 Suction	AI-034	SNVT_count_f (51)	Actual System 2 Suction Pressure (Psig)
nvoPRS_3_DISCH	Pressures 3 Discharge (70-150 Ton Only)	AI-035	SNVT_count_f (51)	Actual System 3 Discharge Pressure (Psig)
nvoPRS_3_SUCTION	Pressures 3 Suction (70-150 Ton Only)	AI-036	SNVT_count_f (51)	Actual System 3 Suction Pressure (Psig)
nviRAT_COOL_SP	Rat Cooling Setp	AV-023	SNVT_count_f (51)	On A VAV Or Flexsys Unit This Value Is Used To Determine When The Unit Should Switch To The Cooling Mode (°F)
nvoRET_AIR_BY_S	Active Bypass Active Sp	AI-037	SNVT_switch (95)	A Derived Value For The Current Setpoint Of The Return Air Bypass Damper On A Flexsys Unit (%)

**TABLE 38 – LON POINTS LIST (SEE NOTES AT END OF TABLE) (CONT'D)**

BACNET NAME	USER INTERFACE NAME	BACNET OBJECT TYPE AND INSTANCE	SNVT	POINTS LIST DESCRIPTION
nvoRET_AIR_ENTH	Return Air Enthalpy	AI-038	SNVT_count_f (51)	Actual Return Air Enthalpy (Btu/Lb)
nvoRET_AIR_HUMD	Return Air Humidity	AI-039	SNVT_switch (95)	Actual Return Air Relative Humidity (%)
nvoRET_AIR_TEMP	Return Air Temp	AI-040	SNVT_count_f (51)	Actual Return Air Temperature (°F)
RET_FAN_OUT	Exhaust/Return Fan VFD	AI41		The Output From The Control To The Exhaust Or Return Fan VFD (%)
nvoRET_FAN_PRES	Return Fan Pressure	AI-042	SNVT_count_f (51)	The Actual Pressure That Is Used To Control The Return Fan ("W.C.)
nvoRET_FAN_STAT	Return Fan Status	BI-052	SNVT_switch (95)	The Status Of The Return Fan Run Verification Circuit (Run - Verification Circuit Closed / Sto - Stop - Verification Circuit Open)
nviSAT_HIGH_LIM	Sat High Limit	AV-026	SNVT_count_f (51)	The Upper Limit For The Supply Air Temperature Setpoint On A VAV Unit (°F)
nviSAT_LOW_LIM	Sat Low Limit	AV-027	SNVT_count_f (51)	The Lower Limit For The Supply Air Temperature Setpoint On A VAV Unit (°F)
nviSAT_RST_BAS	Supply Air Temp RST BAS	AV-028	SNVT_count_f (51)	This Is An Analog Input From The BAS System That Allows The Reset Of The Active Supply Air Temperature Setpoint On VAV Units. 0 Volts Uses Sat High Limit And 5 Volts Uses Sat Low Limit (V). "Sat RST BAS" Must Be Enabled Using The Service Key In Order To Use This Feature
nvoSAT_SUC_TMP1	Saturated Suction Temp (Temperatures 1 Suction)	AI-043	SNVT_count_f (51)	The Saturation Temperature Of The System 1 Suction Gas Based On The System 1 Suction Pressure (°F)
nvoSAT_SUC_TMP2	Saturated Suction Temp (Temperatures 2 Suction)	AI-044	SNVT_count_f (51)	The Saturation Temperature Of The System 2 Suction Gas Based On The System 2 Suction Pressure (°F)
nvoSAT_SUC_TMP3	Saturated Suction Temp (Temperatures 3 Suction) (70-150 Ton Only)	AI-045	SNVT_count_f (51)	The Saturation Temperature Of The System 3 Suction Gas Based On The System 3 Suction Pressure (°F)
nvoSEN_MSC_FLT	Sensor / Misc Fault	BI-054	SNVT_switch (95)	Identifies If A Sensor Or Miscellaneous Fault Is Present (0 - No Fault; 1 - Faulted)
nvoSF_PROV_SW	Sf Proving Switch	BI-055	SNVT_switch (95)	The Status Of The Supply Fan Air Proving Circuit (Run - Verification Circuit Closed / Sto - Stop - Verification Circuit Open)
nviSTG_1_COOL	Stg 1 Cooling	AV-031	SNVT_count_f (51)	For A CV/SZVAV Unit This Is The Active Sat Setpoint For A First Stage Cooling Demand (°F)

**TABLE 38 – LON POINTS LIST (SEE NOTES AT END OF TABLE) (CONT'D)**

BACNET NAME	USER INTERFACE NAME	BACNET OBJECT TYPE AND INSTANCE	SNVT	POINTS LIST DESCRIPTION
nviSTG_1_HEAT	Stg 1 Heating	AV-032	SNVT_count_f (51)	For A CV/SZVAV Unit This Is The Active Sat Setpoint For A First Stage Heating Demand (°F)
nviSTG_2_COOL	Stg 2 Cooling	AV-033	SNVT_count_f (51)	For A CV/SZVAV Unit This Is The Active Sat Setpoint For A Second Stage Cooling Demand (°F)
nviSTG_2_HEAT	Stg 2 Heating	AV-034	SNVT_count_f (51)	For A CV/SZVAV Unit This Is The Active Sat Setpoint For A Second Stage Heating Demand (°F)
nvoSUP_AIR_TEMP	Supply Air Temp	AI-046	SNVT_count_f (51)	Actual Supply Air Temperature (°F)
nvoSUP_AIR_TRST	Supply Air Temp Rst	A-0147	SNVT_count_f (51)	This Is Either A Hardwired Or Communicated 0 To 5Vdc Input That Adjust The Supply Air Setpoint Between The Sat Low And Sat High Limit (V)
SUP_FAN_VFD	Supply Fan VFD	AI48		The Actual Ouput To The Supply Fan VFD (%)
nvoSUPPLY_FAN	Supply Fan	BI-059	SNVT_switch (95)	The Status Of The Binary Ouput From The Controller To The Supply Fan Circuit (On / Off)
nviSYSTEM_STOP	System Stop	AV-035	SNVT_count (8)	A 0- Vallue Allows All Compressors To Operate; 1 - Turns Off Compressor System 1; 2 - Turns Off Compressor System 2; 3 - Turns Off Compressor System 3
nvoTEMP_1_SUCTION	Temperature 1 Suction	AI-049	SNVT_count_f (51)	The Actual Temperature Of The System 1 Suction Line (°F)
nvoTEMP_2_SUCTION	Temperature 2 Suction	AI-051	SNVT_count_f (51)	The Actual Temperature Of The System 2 Suction Line (°F)
nvoTEMP_3_SUCTION	Temperature 3 Suction	AI-053	SNVT_count_f (51)	The Actual Temperature Of The System 3 Suction Line (°F)
nvoUND_FLR_DEWP	Under Floor Dew Point	AI-055	SNVT_count_f (51)	The Calaculated Dew Point Of The Air Under The Floor In A Flexsys System (%)
nviUND_HUMD_BAS	Under Floor Humidity BAS	AV-036	SNVT_switch (95)	This Allows The BAS System To Input A Under Floor Humidity Value To The Control On A Flexsys System (%) "Under Flr Humi BAS" Must Be Enabled Using The Service Key In Order To Use This Feature
nvoUND_FLR_HUMD	Under Floor Humidity	AI-056	SNVT_switch (95)	Humidity Value Of The Air Under The Floor The Control Is Controlling To In A Flexsys System (%)
nviUND_TEMP_BAS	Under Floor Temp BAS	AV-037	SNVT_count_f (51)	This Allows The BAS System To Input A Under Floor Temperature Value To The Control On A Flexsys System (°F). "Under Flr Temp BAS" Must Be Enabled Using The Service Key In Order To Use This Feature
nvoUND_FLR_TEMP	Under Floor Temp	AI-057	SNVT_count_f (51)	Temperature Of The Air Under The Floor The Control Is Controlling To In A Flexsys System (°F)

**TABLE 38– LON POINTS LIST (SEE NOTES AT END OF TABLE) (CONT'D)**

BACNET NAME	USER INTERFACE NAME	BACNET OBJECT TYPE AND INSTANCE	SNVT	POINTS LIST DESCRIPTION
nvoUNIT_MODE	Unit Mode	AI-058	SNVT_count (8)	0 - Occupied Cooling 1 - Occupied Cooling Low 2 - Occupied Cooling High 3 - Occupied Cooling With Bypass 4 - Occupied Cooling Without Bypass 5 - Occupied Heating 6 - Occupied Heating Low 7 - Occupied Heating High 8 - Occupied Standby 9 - Unoccupied Cooling 10 - Unoccupied Cooling Low 11 - Unoccupied Cooling High 12 - Unoccupied Heating 13 - Unoccupied Heating Low 14 - Unoccupied Heating High 15 - Unoccupied Standby 16 - Comfort Vent Cooling 17 - Comfort Vent Heating 18 - Night Set Back 19 - Morning Warm Up 20 - Power Up Standby
nviUNIT_STOP	Unit Stop	AV-093	SNVT_switch (95)	This Command Allows The Unit To Be Shut Down Through The BAS System (0 = Normal Operation/ 1 = Stopped)
nviUNOCC_ZN_COOL	Unoccupied Zone Cooling	AV-038	SNVT_count_f (51)	The Unoccupied Zone Cooling Setpoint (°F)
nviUNOCC_ZN_HEAT	Unoccupied Zone Heating	AV-039	SNVT_count_f (51)	The Unoccupied Zone Heating Setpoint (°F)
nvoVENT_DEM_OUT	Ventilation Demand P1 Outp	AI-059	SNVT_switch (95)	The Ventilation Output Being Generated By The Demand Ventilation Feature (%)
nviVENT_ENABLE	Ventilation Enable	AV-095	SNVT_switch (95)	This Command Allows The Ventilation Function To Be Turned On Or Off (0 = Off / 1 = On)
nviZONE_TMP_BAS	Zone Temp BAS	AV-040	SNVT_count_f (51)	This Allows The BAS System To Input A Zone Temperature Value To The Control On A CV/SZVAV Unit With Communicated Zone Control (°F)
nvoZONE_TEMP	Zone Temp	AI-060	SNVT_count_f (51)	Zone Temperature The Control Is Controlling To (°F)

**NOTES**

1. The most up to date listing of the Standard Points Mapping can be found on the JCI website
2. For a Building Automation System using LON, an JCI E-link MUST be used
  - a. YK-ELNK101-0
  - b. YK-ELNKE01-0 (w/ enclosure)

TABLE 39 - N2 POINTS LIST

BACNET NAME	USER INTERFACE NAME	READ/ WRITE	BACNET OBJECT TYPE AND INSTANCE	ENG UNITS	N2 ADDRESS	POINTS LIST DESCRIPTION
ACT_DSP_SP	Duct Static Setpoint	R	AI01	WC	AI 1	A Derived Value The Duct Static Is Controlled To ("W.C.)
ACT_MIN_FLOW	Active Minimum Air Flow	R	AI02	CFM	AI 2	A Derived Value The Minimum Ventilation Air Is Controlled To (CFM)
ACT_MIN_POS	Active Minimum Position	R	AI03	%	AI 3	A Derived Value The Damper Is Controlled To For Minimum Ventilation Air (%)
ACT_SAT_SP	Supply Air Setp	R	AI04	°F	AI 4	A Derived Value The Supply Air Temperature Is Controlled To (°F)
ACT_SLAB_CTL	Active Slab Control	R/W	AV77	0, 1	AO 34	Allows The Active Slab Control Feature To Be Turned On And Off On Flexsys Units (0 = Off / 1 = On)
BUILD_PRES_SP	Building Pressure Sp	R/W	AV01	WC	AO 1	The Building Pressure Setpoint ("W.C.)
BLD_STAT_PRS	Building Static Pres	R	AI05	WC	AI 5	Actual Building Pressure Input ("W.C.)
BYPASS_DAMPER	Bypass Damper	R	AI06	%	AI 6	Actual Bypass Damper Position (%)
CO2_1_OUT	CO <sub>2</sub> 1					
(OUTSIDE)	R	AI07	PPM	AI 7	Actual Outdoor CO <sub>2</sub> Value (PPM)	
CO2_2_INSIDE	CO <sub>2</sub> 1 (Inside)	R	AI08	PPM	AI 8	Actual Indoor CO <sub>2</sub> Value (Ppm)
CO2_OFFSET	CO <sub>2</sub> Offset	R/W	AV02	PPM	AO 2	The Difference Between The Indoor And Outside CO <sub>2</sub> Must Exceed This Value To Initiate Demand Ventilation (Ppm)
COL_HEAT_FLT	Cooling/Heating Fault	R	BI02	0, 1	DI 1	Gives The Fault Status Of The Cooling And Heating System (Nfl - No Fault; Flt - Faulted)
COMP_1A	Compressor 1A	R	BI03	0, 1	DI 2	Status Of Compressor 1A, (0 = Off, 1 = On)
COMP_1B	Compressor 1B	R	BI04	0, 1	DI 3	Status Of Compressor 1B, (0 = Off, 1 = On)
COMP_2A	Compressor 2A	R	BI05	0, 1	DI 4	Status Of Compressor 2A, (0 = Off, 1 = On)
COMP_2B	Compressor 2B	R	BI06	0, 1	DI 5	Status Of Compressor 2B, (0 = Off, 1 = On)
COMP_3A	Compressor 3A (70-150 Ton Only)	R	BI07	0, 1	DI 6	Status Of Compressor 3A, (0 = Off, 1 = On)
COMP_3B	Compressor 3B	R	BI08	0, 1	DI 7	Status Of Compressor 3B, (0 = Off, 1 = On)
COMP_LPCO_1	Compressor LPCO 1	R	BI09	0, 1	DI 8	Status Of Compressor System 1 Low Pressure Cutout Circuit (0 - Faulted / 1 - No Fault )
COMP_LPCO_2	Compressor LPCO 2	R	BI10	0, 1	DI 9	Status Of Compressor System 2 Low Pressure Cutout Circuit (0 - Faulted / 1 - No Fault )



**TABLE 39 – N2 POINTS LIST (SEE NOTES AT END OF TABLE) (CONT'D)**

BACNET NAME	USER INTERFACE NAME	READ/ WRITE	BACNET OBJECT TYPE AND INSTANCE	ENG UNITS	N2 ADDRESS	POINTS LIST DESCRIPTION
COMP_LPCO_3	Compressor LPCO 3 (70-150 Ton Only)	R	BI11	0, 1	DI 10	Status Of Compressor System 3 Low Pressure Cutout Circuit (0 - Faulted / 1 - No Fault )
COMP_STAT_1	Compressor Status 1	R	BI12	0, 1	DI 11	Status Of Compressor System 1 Compressor Safety Circuit (0 - Faulted / 1 - No Fault )
COMP_STAT_2	Compressor Status 2	R	BI13	0, 1	DI 12	Status Of Compressor System 2 Compressor Safety Circuit (0 - Faulted / 1 - No Fault )
COMP_STAT_3	Compressor Status 3 (70-150 Ton Only)	R	BI14	0, 1	DI 13	Status Of Compressor System 3 Compressor Safety Circuit (0 - Faulted / 1 - No Fault )
DCT_ST_PR_RT	Duct Static Pres Rst	R	AI16	%	AI 9	A Hardwired Entered Analog Voltage That Results In A %Reset Down From The Duct Static High Limit Based On A Percent Of The Difference Between Duct Static High Limit And Duct Static Low Limit (%)
DCT_STAT_PRS	Duct Static Pres	R	AI17	WC	AI 10	Actual Duct Static Pressure Input To The Control ("W.C.)
DEW_PNT_RST	Dew Point Reset	R/W	AV80	0, 1	AO 35	This Allows The Dew Point Reset Feature To Be Turned On And Off On Flexsys Units (0 = Off / 1 = On)
DSP_HI_LIMIT	Duct Static High Limit	R/W	AV03	WC	AO 3	The Duct Static Upper Setpoint ("W.C.)
DSP_LO_LIMIT	Duct Static Low Limit	R/W	AV04	WC	AO 4	The Duct Static Lower Setpoint ("W.C.)
DSP_RST_BAS	Duct Static Pres RST BAS	R/W	AV05	%	AO 5	A BAS Entered Value That Results In A %Reset Down From The Duct Static High Limit Based On A Percent Of The Difference Between Duct Static High Limit And Duct Static Low Limit (%). "Duct Pres RST BAS" Must Be Enabled Using The Service Key In Order To Use This Feature
ECONO_INSTAL	Economizer Installed	R/W	AV81	0, 1	AO 36	Allows The Economizer Feature To Be Turned On And Off (0 = Off / 1 = On)
ECON_ME_USED	Economizer Method	R	AI18	INDEX	AI 11	The Economizer Method Being Used By The Control (0 - Dry Bulb; 1 - Single Enthalpy; 2 - Dual Enthalpy)
ECON_STATUS	Economizer Suitable Econ Installed	R	AI19	INDEX	AI 12	Status Of The Economizer Option (0 - Installed And Inactive; 1 - Installed And Active; 2 - Not Installed)
EL_AIR_TMP_H	Evap Leaving Air Temp High	R/W	AV07	°F	AO 6	On A Flexsys Unit With Bypass This Is The Supply Air Temperature High Setpoint (°F)
EL_AIR_TMP_L	Evap Leaving Air Temp Low	R/W	AV08	°F	AO 7	On A Flexsys Unit With Bypass, This Is The Supply Air Temperature Low Setpoint (°F)

**6**

**TABLE 39 – N2 POINTS LIST (SEE NOTES AT END OF TABLE) (CONT'D)**

BACNET NAME	USER INTERFACE NAME	READ/ WRITE	BACNET OBJECT TYPE AND INSTANCE	ENG UNITS	N2 ADDRESS	POINTS LIST DESCRIPTION
EVAP_AIR_TMP	Evaporator Air Temp 1	R	AI20	°F	AI 13	Actual Temperature Of Air Leaving The Evaporator Coil On A Flexsys Unit (°F)
EXHAUST_FAN	Exhaust Fan	R	BI22	0, 1	DI 15	The Status Of The Binary Output For The Exhaust ( 0 = Off / 1 = On)
EXH_FAN_STAT	Exhaust Fan Status	R	BI21	0, 1	DI 14	The Status Of The Exhaust Fan Run Verification Circuit (0 - Verification Circuit Open / 1 - Verification Circuit Closed)
EXHAUST_OUT	Exhaust Output	R	AI21	%	AI 14	Control Output To The Exhaust Damper (%)
FAN_FAULT	Fan Fault	R	BI23	0, 1	DO 16	Identifies If There Is A Supply, Exhaust, Or Return Fan Fault (0 - No Fault; 1 - Faulted)
FILTER_STATS	Filter Status	R	BI25	0, 1	DO 17	Identifies The Status Of The Binary Dirty Filter Input ( 0 - No Fault; 1 - Faulted)
HEAT_ENT_TMP	Heat Entering Temp	R	AI22	°F	AI 15	Actual Temperature Of The Air Entering The Staged Heat Section (°F)
HEATING_SAT	Heating Sat	R/W	AV09	°F	AO 8	The Heating Sat Setpoint For A VAV Or Flexsys Unit (°F)
HEAT_STAGES	Electric Heat Stages Gas Heat Stages	R	AI23	INDEX	AI 16	Derived Value Showing The Number Of Electric Or Staged Gas Heat Stages Available (1 - 7)
HEATING_VALV	Heating Valve	R	AI24	%	AI 17	The Output From The Control To A Hot Water, Steam, Or Modulating Gas Heat Valve (%)
HW_FRZ_STAT	Hot Water Frz Status	R	BI33	0, 1	DO 18	The Status Of The Freezestat Circuit On Units With Hot Water Or Steam Heat. (0 - No Fault / 1 - Faulted)
MAX_BYPASS	Maximum Bypass	R/W	AV10	%	AO 9	The Maximum Allowable Setting For The By Pass Damper In A Flexsys Unit (%)
MAX_FLOW_DV	Max Flow Demand Ventilation	R/W	AV11	CFM	AO 10	The Maximum Allowable Airflow For Demand Ventilation With An Air Measuring Station (CFM)
MECH_LCK_TMP	Mech Clg Lockout Temp	R/W	AV12	°F	AO 11	The Minimum Outdoor Temperature At Which Mechanical Cooling Is Allowed To Operate (°F)
MIN_FLOW_DV	Min Flow Demand Ventilation	R/W	AV13	CFM	AO 12	The Minimum Allowable Airflow For Demand Ventilation With An Air Measuring Station (CFM)
MIXD_SAT_LIM	Mixed Sat Limit	R/W	AV14	°F	AO 13	On A Flexsys Unit This Is The Supply Air Setpoint When Operating Without A Bypass Damper (°F)
MORN_WUP_CMD	Morning Warm Up Cmnd	R/W	AV 86	0, 1	AO 37	A BAS Generated Command To Allow The Morning Warm Up Feature To Be Turned On And Off (0 = Off / 1 = On)

**TABLE 39 – N2 POINTS LIST (SEE NOTES AT END OF TABLE) (CONT'D)**

BACNET NAME	USER INTERFACE NAME	READ/ WRITE	BACNET OBJECT TYPE AND INSTANCE	ENG UNITS	N2 ADDRESS	POINTS LIST DESCRIPTION
MORN_WUP_RAT	Rat Heating Setp	R/W	AV15	°F	AO 14	On A VAV Or Flexsys Unit This Is The Return Air Temperature Setpoint Used To Determine When The Unit Should Switch To The Heating Mode (°F)
NIGHT_SETBAC	Night Set Back (For Heating)	R/W	AV87	0, 1	AO 38	This Command Allows The Night Set Back Heating Function To Be Turned On And Off (0 = Off / 1 = On)
OA_DAMPER	Oa Damper	R	AI25	%	AI 18	This Is The Position Of The Outdoor Damper (%)
OA_DAMP_POS1	Oa Damper Min Position 1	R/W	AV16	%	AO 15	The Minimum Position For The Outdoor Air Damper When Using Fixed Ventilation Control When The Supply Fan Is At Full Speed (%)
OA_DAMP_POS2	Oa Damper Min Position 2	R/W	AV17	%	AO 16	The Minimum Position For The Outdoor Air Damper When Using Fixed Ventilation Control When The Supply Fan Is At 50% Of Full Speed (%)
OA_ENTHALPY	Outside Air Enthalpy	R	AI26	BTU/ LB	AI 19	Actual Outside Air Enthalpy (Btu/Lb)
OA_ENTH_LIMT	Outside Air Enthalpy Setpoint	R/W	AV18	BTU/ LB	AO 17	The Upper Enthalpy Limit To Allow The Use Of Outdoor Air For Single Or Dual Enthalpy Economizer (Btu/Lb)
OA_FLO_PRS_1	Oa Flow Pressure 1	R	AI27	WC	AI 20	Not Used
OA_FLO_PRS_2	Oa Flow Pressure 2	R	AI28	WC	AI 21	Not Used
OA_REL_HUMID	Outside Air Humidity	R	AI29	%	AI 22	Actual Outdoor Air Relative Humidity (%)
OA_TEMP	Outside Air Temp	R	AI30	°F	AI 23	Actual Outdoor Air Temperature (°F)
OCCUPNCY_CMD	Occupancy Command	R/W	AV88	0, 1	AO 39	This BAS Command Allows The Unit To Be Placed In The Occupied Or Unoccupied Mode (0 = Unoccupied / 1 = Occupied)
OCC_ZN_COOL	Occupied Zone Cooling Setp	R/W	AV21	°F	AO 18	The Occupied Zone Cooling Setpoint (°F)
OCC_ZN_HEAT	Occupied Zone Heating Setp	R/W	AV22	°F	AO 19	The Occupied Zone Heating Setpoint (°F)
PRS_1_DISCH	Pressures 1 Discharge	R	AI31	PSI	AI 24	Actual System 1 Discharge Pressure (Psi)
PRS_1_SUCTION	Pressures 1 Suction	R	AI32	PSI	AI 25	Actual System 1 Suction Pressure (Psi)
PRS_2_DISCH	Pressures 2 Discharge	R	AI33	PSI	AI 26	Actual System 2 Discharge Pressure (Psi)
PRS_2_SUCTION	Pressures 2 Suction	R	AI34	PSI	AI 27	Actual System 2 Suction Pressure (Psi)

**TABLE 39 – N2 POINTS LIST (SEE NOTES AT END OF TABLE) (CONT'D)**

BACNET NAME	USER INTERFACE NAME	READ/ WRITE	BACNET OBJECT TYPE AND INSTANCE	ENG UNITS	N2 ADDRESS	POINTS LIST DESCRIPTION
PRS_3_DISCH	Pressures 3 Discharge (70-150 Ton Only)	R	AI35	PSI	AI 28	Actual System 3 Discharge Pressure (Psi)
PRS_3_SUCTION	Pressures 3 Suction (70-150 Ton Only)	R	AI36	PSI	AI 29	Actual System 3 Suction Pressure (Psi)
RAT_COOL_SP	Rat Cooling Setp	R/W	AV23	°F	AO 20	On A VAV Or Flexsys Unit This Value Is Used To Determine When The Unit Should Switch To The Cooling Mode (°F)
RET_AIR_BY_S	Active Bypass Active Sp	R	AI37	%	AI 30	A Derived Value For The Current Setpoint Of The Return Air Bypass Damper On A Flexsys Unit (%)
RET_AIR_ENTH	Return Air Enthalpy	R	AI38	BTU/ LB	AI 31	Actual Return Air Enthalpy (Btu/Lb)
RET_AIR_HUMD	Return Air Humidity	R	AI39	%	AI 32	Actual Return Air Relative Humidity (%)
RET_AIR_TEMP	Return Air Temp	R	AI40	°F	AI 33	Actual Return Air Temperature (°F)
RET_FAN_OUT	Exhaust/Return Fan Vfd	R	AI41	%	AI 34	The Output From The Control To The Exhaust Or Return Fan Vfd (%)
RET_FAN_PRES	Return Fan Pressure	R	AI42	WC	AI 35	The Actual Pressure That Is Used To Control The Return Fan ("W.C.)
RET_FAN_STAT	Return Fan Status	R	BI52	0, 1	DI 19	The Status Of The Return Fan Run Verification Circuit ( 0 - Stop - Verification Circuit Open / 1 - Verification Circuit Closed)
SAT_HIGH_LIM	Sat High Limit	R/W	AV26	°F	AO 21	The Upper Limit For The Supply Air Temperature Setpoint On A VAV Unit (°F)
SAT_LOW_LIM	Sat Low Limit	R/W	AV27	°F	AO 22	The Lower Limit For The Supply Air Temperature Setpoint On A VAV Unit (°F)
SAT_RST_BAS	Supply Air Temp Rst BAS	R/W	AV28	VOLTS DC	AO 23	This Is An Analog Input From The BAS System That Allows The Reset Of The Active Supply Air Temperature Setpoint On VAV Units. 0 Volts Uses Sat High Limit And 5 Volts Uses Sat Low Limit (V). "Sat RST BAS" Must Be Enabled Using The Service Key In Order To Use This Feature
SAT_SUC_TMP1	Saturated Suction Temp (Temperatures 1 Suction)	R	AI43	°F	AI 36	The Saturation Temperature Of The System 1 Suction Gas Based On The System 1 Suction Pressure (°F)
SAT_SUC_TMP2	Saturated Suction Temp (Temperatures 2 Suction)	R	AI44	°F	AI 37	The Saturation Temperature Of The System 2 Suction Gas Based On The System 2 Suction Pressure (°F)

**TABLE 39 – N2 POINTS LIST (SEE NOTES AT END OF TABLE) (CONT'D)**

BACNET NAME	USER INTERFACE NAME	READ/ WRITE	BACNET OBJECT TYPE AND INSTANCE	ENG UNITS	N2 ADDRESS	POINTS LIST DESCRIPTION
SAT_SUC_TMP3	Saturated Suction Temp (Temperatures 3 Suction) (70-150 Ton Only)	R	AI45	°F	AI 38	The Saturation Temperature Of The System 3 Suction Gas Based On The System 3 Suction Pressure (°F)
SEN_MSC_FLT	Sensor/Misc Fault	R	BI54	0, 1	DI 20	Identifies If A Sensor Or Miscellaneous Fault Is Present (0 - No Fault; 1 - Faulted)
SF_PROV_SW	Sf Proving Switch	R	BI55	0, 1	DI 21	The Status Of The Supply Fan Air Proving Circuit (0 - Verification Circuit Open / 1 - Verification Circuit Closed)
STG_1_COOL	Stg 1 Cooling	R/W	AV31	°F	AO 24	For A Constant Volume Unit This Is The Active Sat Setpoint For A First Stage Cooling Demand (°F)
STG_1_HEAT	Stg 1 Heating	R/W	AV32	°F	AO 25	For A Constant Volume Unit This Is The Active Sat Setpoint For A First Stage Heating Demand (°F)
STG_2_COOL	Stg 2 Cooling	R/W	AV33	°F	AO 26	For A Constant Volume Unit This Is The Active Sat Setpoint For A Second Stage Cooling Demand (°F)
STG_2_HEAT	Stg 2 Heating	R/W	AV34	°F	AO 27	For A Constant Volume Unit This Is The Active Sat Setpoint For A Second Stage Heating Demand (°F)
SUP_AIR_TEMP	Supply Air Temp	R	AI46	°F	AI 39	Actual Supply Air Temperature (°F)
SUP_AIR_TRST	Supply Air Temp Rst	R	AI47	VOLTS DC	AI 40	This Is Either A Hardwired Or Communicated 0 To 5Vdc Input That Adjust The Supply Air Setpoint Between The Sat Low And Sat High Limit (V)
SUP_FAN_VFD	Supply Fan Vfd	R	AI48	%	AI 41	The Actual Output To The Supply Fan Vfd (%)
SUPPLY_FAN	Supply Fan	R	BI59	0, 1	DI 22	The Status Of The Binary Output From The Controller To The Supply Fan Circuit (0 = Off, 1 = On)
SYSTEM_STOP	System Stop	R/W	AV35	INDEX	AO 28	A 0- Value Allows All Compressors To Operate; 1 - Turns Off Compressor System 1; 2 - Turns Off Compressor System 2; 3 - Turns Off Compressor System 3
TEMP_1_SUCTION	Temperature 1 Suction	R	AI49	°F	AI 42	The Actual Temperature Of The System 1 Suction Line (°F)
TEMP_2_SUCTION	Temperature 2 Suction	R	AI51	°F	AI 43	The Actual Temperature Of The System 2 Suction Line (°F)
TEMP_3_SUCTION	Temperature 3 Suction (70-150 Ton Only)	R	AI53	°F	AI 44	The Actual Temperature Of The System 3 Suction Line (°F)

**6**

**TABLE 39 – N2 POINTS LIST (SEE NOTES AT END OF TABLE) (CONT'D)**

BACNET NAME	USER INTERFACE NAME	READ/ WRITE	BACNET OBJECT TYPE AND INSTANCE	ENG UNITS	N2 ADDRESS	POINTS LIST DESCRIPTION
UND_FLR_DEWP	Under Floor Dew Point	R	AI55	°F	AI 45	The Calculated Dew Point Of The Air Under The Floor In A Flexsys System (°F)
UND_HUMD_BAS	Under Floor Humidity BAS	R/W	AV36	%	AO 29	This Allows The BAS System To Input A Under Floor Humidity Value To The Control On A Flexsys System (%) "Under Flr Humi BAS" Must Be Enabled Using The Service Key In Order To Use This Feature
UND_FLR_HUMD	Under Floor Humidity	R	AI56	%	AI 46	Humidity Value Of The Air Under The Floor The Control Is Controlling To In A Flexsys System (%)
UND_TEMP_BAS	Under Floor Temp BAS	R/W	AV37	°F	AO 30	This Allows The BAS System To Input A Under Floor Temperature Value To The Control On A Flexsys System (°F). "Under Flr Temp BAS" Must Be Enabled Using The Service Key In Order To Use This Feature
UND_FLR_TEMP	Under Floor Temp	R	AI57	°F	AI 47	Temperature Of The Air Under The Floor The Control Is Controlling To In A Flexsys System (°F)
UNIT_MODE	Unit Mode	R	AI58	INDEX	AI 48	0 - Occupied Cooling 1 - Occupied Cooling Low 2 - Occupied Cooling High 3 - Occupied Cooling With Bypass 4 - Occupied Cooling Without Bypass 5 - Occupied Heating 6 - Occupied Heating Low 7 - Occupied Heating High 8 - Occupied Standby 9 - Unoccupied Cooling 10 - Unoccupied Cooling Low 11 - Unoccupied Cooling High 12 - Unoccupied Heating 13 - Unoccupied Heating Low 14 - Unoccupied Heating High 15 - Unoccupied Standby 16 - Comfort Vent Cooling 17 - Comfort Vent Heating 18 - Night Set Back 19 - Morning Warm Up 20 - Power Up Standby
UNIT_STOP	Unit Stop	R/W	AV93	0, 1	AO 40	This Command Allows The Unit To Be Shut Down Through The BAS System (0 = Normal Operation/ 1 = Stopped)
UNOCC_ZN_COOL	Unoccupied Zone Cooling	R/W	AV38	°F	AO 31	The Unoccupied Zone Cooling Setpoint (°F)
UNOCC_ZN_HEAT	Unoccupied Zone Heating	R/W	AV39	°F	AO 32	The Unoccupied Zone Heating Setpoint (°F)

**TABLE 39 – N2 POINTS LIST (SEE NOTES AT END OF TABLE) (CONT'D)**

BACNET NAME	USER INTERFACE NAME	READ/ WRITE	BACNET OBJECT TYPE AND INSTANCE	ENG UNITS	N2 ADDRESS	POINTS LIST DESCRIPTION
<b>VENT_DEM_OUT</b>	Ventilation Demand P1 Outp	R	AI59	%	AI 49	The Ventilation Output Being Generated By The Demand Ventilation Feature (%)
<b>VENT_ENABLE</b>	Ventilation Enable	R/W	AV95	0, 1	AO 41	This Command Allows The Ventilation Function To Be Turned On Or Off (0 = Off / 1 = On)
<b>ZONE_TMP_BAS</b>	Zone Temp BAS	R/W	AV40	°F	AO 33	This Allows The BAS System To Input A Zone Temperature Value, °F, To The Control. To Use This Feature The “Control Method” Must Be Set To “Comm Zone Temp”
<b>ZONE_TEMP</b>	Zone Temp	R	AI60	°F	AI 50	Zone Temperature The Control Is Controlling To (°F)

**NOTES**

1. The most up to date listing of the Standard Points Mapping can be found on the JCI website
2. For a Building Automation System using N2, an JCI E-link MUST be used
  - a. a-YK-ELNK100-0
  - b. b- YK-ELNKE00-0 (w/ enclosure)

THIS PAGE INTENTIONALLY LEFT BLANK



## SECTION 7 – PARAMETER DESCRIPTIONS AND OPTIONS

**TABLE 40 - DEFINITIONS**

MENU ITEM	DEFINITION
<b>ACTIVE SLAB CONTROL</b>	This parameter is programmed through the PROGRAM key. This function allows heat to be turned ON during the transition from Unoccupied to Occupied mode or Occupied to Unoccupied mode if the under floor conditions of a FlexSys system are right for the growth of mold and mildew. The choices are USER ENABLED or USER DISABLED.
<b>ADAPT MORN WARM UP</b>	This parameter is programmed through the PROGRAM key. Adaptive Morning Warm Up uses the past three days of warm up times and temperatures to calculate the start time for the current day. This parameter allows the user to USER ENABLED or USER DISABLED this feature.
<b>BLDG PRESSURE CNTRL OFFSET</b>	This parameter is programmed through the SETPOINTS key. The Unit Controller To determine when to turn on the exhaust fan. When the exhaust option is configured for “ON-OFF PRESS CNTRL”.
<b>BUILDING PRESSURE ACTIVE SETPOINT</b>	This parameter is programmed through the SETPOINTS key. It identifies the control point for the building pressure.
<b>BUILDING PRESSURE CURRENT</b>	This is the actual pressure in the conditioned space.
<b>BYPASS DAMPER POSITION</b>	This is the actual position of the bypass damper, by percent open, in a FlexSys unit.
<b>CO<sub>2</sub> LEVEL INSIDE</b>	This is the CO <sub>2</sub> level of the air in the conditioned space.
<b>CO<sub>2</sub> LEVEL OUTSIDE</b>	This is the CO <sub>2</sub> level of the outdoor air.
<b>CO<sub>2</sub> OFFSET SETPOINT</b>	This parameter is programmed through the SETPOINTS key. The Outside CO <sub>2</sub> level must be lower than the Indoor CO <sub>2</sub> level plus the CO <sub>2</sub> OFFSET SETPOINT before the outdoor door damper will start to open for additional ventilation.
<b>CO<sub>2</sub> OFFSET CURRENT</b>	This represents the current difference between the “CO <sub>2</sub> LEVEL INSIDE” versus the “CO <sub>2</sub> LEVEL OUTSIDE”.
<b>COMFORT VENTILATION</b>	This parameter is programmed through the PROGRAM key. This function is only used on a Constant Volume unit. The Unit Controller monitors the Return Air Temperature and energizes stages of cooling or heating prior to a demand from the space. This function is only active when the unit is in the Occupied mode. The choices are USER ENABLED or USER DISABLED.
<b>COMP SYS 1 STATUS</b>	This is the current operating mode of the system 1 compressors. The display will show Normal - Comp A On, Normal - Comp B On, Normal - Both ON, Normal - Both Off, Safety Trip, Safety Fault, Safety Lockout, Low Amb Inhibit, Low Suct Temp Unl, High DP Unload, or User Disabled.
<b>COMP SYS 2 STATUS</b>	This is the current operating mode of the system 2 compressors. The display will show Normal - Comp A On, Normal - Comp B On, Normal - Both ON, Normal - Both Off, Safety Trip, Safety Fault, Safety Lockout, Low Amb Inhibit, Low Suct Temp Unl, High DP Unload, or User Disabled.
<b>COMP SYS 3 STATUS</b>	This is the current operating mode of the system 3 compressors. The display will show Normal - Comp A On, Normal - Comp B On, Normal - Both ON, Normal - Both Off, Safety Trip, Safety Fault, Safety Lockout, Low Amb Inhibit, Low Suct Temp Unl, High DP Unload, or User Disabled.
<b>CONDENSER FAN 1A/1</b>	This identifies if the Unit Controller has sent a Binary output to Condenser Fan 1A /1.
<b>CONDENSER FAN 1B/2</b>	This identifies if the Unit Controller has sent a Binary output to Condenser Fan 1B /2.
<b>CONDENSER FAN 2A/3</b>	This identifies if the Unit Controller has sent a Binary output to Condenser Fan 2A /3.
<b>CONDENSER FAN 2B/4</b>	This identifies if the Unit Controller has sent a Binary output to Condenser Fan 2B/4.
<b>CONDENSER FAN 3A/5</b>	This identifies if the Unit Controller has sent a Binary output to Condenser Fan 3A /5.
<b>CONDENSER FAN 3B/6</b>	This identifies if the Unit Controller has sent a Binary output to Condenser Fan 3B/6.
<b>CONTINUOUS VENT</b>	This parameter is programmed through the PROGRAM key. This is only used on a Constant Volume unit. When this parameter is enabled the supply blower will operate whenever the unit is in the Occupied mode. The choices are USER ENABLED or USER DISABLED.

**TABLE 40 – DEFINITIONS (CONT'D)**

<b>CONTROL METHOD</b>	This parameter is programmed through the OPTIONS key and identifies the control method being used on a Constant Volume unit. The choices are Staged, Wired Zone Temp or Comm Zone Temp.
<b>COOLING CONTROL OFFSET</b>	This is the control band the unit is trying to maintain. The control band is the Active Setpoint +/- the Cooling Control Offset. If the temperature is above this band additional cooling is required, if the temperature is below this band cooling is decreased.
<b>CURRENT OPER MODE</b>	This is the current operating mode of the unit. The display will show OCC Standby, OCC Cooling Low, OCC Cooling High, OCC Heating Low, OCC Heating High, UNOCC Standby, Unnocc Cooling Low, UNOCC Cooling High, UNOCC Heating Low, UNOCC Heating High, Morning Warm-up, Comfort Vent Cooling, Comfort Vent Heating, Occupied Cooling, Occupied Heating, Unoccupied Cooling, Unoccupied Heating, OCC Cooling W/O Bypass, OCC Cooling W Bypass, or Underfloor Temp Override.
<b>CURRENT RUN TIME COMP A</b>	This is the amount of time the compressor has been in operation during the current cycle. This is shown for each compressor of every compressor system.
<b>CURRENT RUN TIME COMP B</b>	This is the amount of time the compressor has been in operation during the current cycle. This is shown for each compressor of every compressor system.
<b>DAILY WARM UP TIME</b>	This is the time it takes to bring the Return Air Temperature up to setpoint during Adaptive Morning Warm Up. The Unit Controller uses this value in the calculation of Daily Warm Up Time Day 1.
<b>DAILY WARM UP TIME DAY 1</b>	This is the Morning Warm Up time the Unit Controller recorded during the previous day 1. This value is used to calculate the current Morning Warm initiate time for Adaptive Morning Warm Up.
<b>DAILY WARM UP TIME DAY 2</b>	This is the Morning Warm Up time the Unit Controller recorded during the previous day 2. This value is used to calculate the current Morning Warm initiate time for Adaptive Morning Warm Up.
<b>DAILY WARM UP TIME DAY 3</b>	This is the Morning Warm Up time the Unit Controller recorded during the previous day 3. This value is used to calculate the current Morning Warm initiate time for Adaptive Morning Warm Up.
<b>DAMPER HARDWARE</b>	This parameter is programmed through the OPTIONS key and identifies the type of ventilation system installed in the unit. The choices are None, 2 Position Damper, Standard Dampers, TEK-AIR.
<b>DEW POINT RESET</b>	This parameter is programmed through the PROGRAM key. This function changes the Active Supply Air Temperature to a lower value when the air beneath the floor of a FlexSys unit approaches the dew point temperature of the air. The choices are USER ENABLED or USER DISABLED.
<b>DISPLAY LANGUAGE</b>	This parameter is programmed through the OPTIONS key. This allows the user to select the language the Unit Controller will use to display the information at the User Interface. The choices are English or Spanish.
<b>DISPLAY UNITS</b>	This parameter is programmed through the OPTIONS key. This allows the user to select which unit of measure the Unit Controller will use to display the information at the User Interface. The choices are Imperial, metric.
<b>DUCT PRESS TRANSDUCER SPAN</b>	This parameter is programmed through the SETPOINTS key. This allows the use of three different duct pressure control ranges, 0 to <b>1.00 in-wg</b> , 0 to <b>2.50 in-wg</b> , or 0 to <b>5.00 in-wg</b> .
<b>DUCT STATIC OVER PRESSURE</b>	This parameter is programmed through the SETPOINTS key. This sets the maximum allowable Duct Static value before the Unit Controller lockouts the unit on an over pressure fault.
<b>DUCT STATIC PRESS ACTIVE SP</b>	This is the current Duct Static Setpoint that the Unit Controller is trying to maintain.
<b>DUCT STATIC PRESS CURRENT</b>	This is the actual duct static pressure value.
<b>DUCT STATIC RESET LOW SETP</b>	This parameter is programmed through the SETPOINTS key. This is the minimum Duct Static Control point.
<b>DUCT STATIC RESET HIGH SETP</b>	This parameter is programmed through the SETPOINTS key. This is the maximum Duct Static Control point.
<b>ECONOMIZER CONTROL OUTPUT</b>	This is the analog output from the Unit Controller to the Economizer Damper Actuator.

**TABLE 40 – DEFINITIONS (CONT'D)**

<b>ECONO INSTALLED</b>	This parameter is programmed through the PROGRAM key and tells the Unit Controller what type of economizer is installed, None, Dry Bulb, Single Enthalpy, Dual Enthalpy.
<b>ECONO METHOD ACTIVE</b>	This value indicates which of the available economizer methods the Unit Controller is using.
<b>ECONO METHOD TO USE</b>	This parameter is programmed through the PROGRAM key and tells the Unit Controller which of the available economizer options to use. The choices are Dry Bulb, Single Enthalpy, Dual Enthalpy, or Best Available.
<b>ECONO OUTPUT FOR FAN START</b>	This parameter is set through the SETPOINTS key and identifies the position of the economizer damper required to turn ON the exhaust fan in an ON/OFF DAMPER CTRL.
<b>ECONO OUTPUT FOR FAN STOP</b>	This parameter is set through the SETPOINTS key and identifies the position of the economizer damper required to turn off the exhaust fan in an ON/OFF DAMPER CTRL option.
<b>ECONO SYS STATUS</b>	This is the active status of the economizer system, display will show Normal- Active, Normal-Inactive, Faulted, User Disabled; or None.
<b>ELEC HEAT CAPACITY</b>	This parameter is programmed through the OPTIONS key. This parameter is used to identify the electric heat capacity installed in the unit. The options are 40 KW, 80 KW, 40 KW-200, 80 KW-200, 100 KW, 100 KW-200, 108 KW, 120 KW, 150 KW, 160 KW, 200 KW, 240 KW, or 250 KW.
<b>EVAP LEAVING AIR TEMP HIGH</b>	This parameter is programmed through the SETPOINTS key. This becomes the Active Supply Air Temperature Setpoint for a FlexSys unit when it is in the Occupied Cooling With Bypass mode.
<b>EVAP LEAVING AIR TEMP LOW</b>	This parameter is programmed through the SETPOINTS key. This becomes the Active Supply Air Temperature Setpoint for a FlexSys unit when it is in the Dew Point Reset mode.
<b>EXHAUST DAMPER POSITION/VFD</b>	This identifies the percentage output from the Unit Controller to the Exhaust Damper or Exhaust Fan when controlled by the unit or BAS (when exhaust Control BAS is enabled).
<b>EXHAUST FAN OUTPUT</b>	This identifies the Unit Controller is sending a Binary output to energize the exhaust fan circuit.
<b>EXHAUST FAN STATUS</b>	This verifies a Binary input to the Unit Controller is present when the exhaust fan is operating.
<b>EXHAUST OUTPUT FOR FAN START</b>	This parameter is set through the SETPOINTS key and identifies the position of the exhaust damper required to turn ON the exhaust fan in an ON/OFF PRESS CNTRL option.
<b>EXHAUST OUTPUT FOR FAN STOP</b>	This parameter is set through the SETPOINTS key and identifies the position of the exhaust damper required to turn off the exhaust fan in an ON/OFF PRESS CNTRL option.
<b>EXHAUST/RETURN FAN VFD</b>	This is a derived value that indicates the output, in percent, to the Return Fan VFD.
<b>EXHAUST SYS STATUS</b>	This is the active status of the exhaust system. The display will show Normal-Active, Normal-Inactive, Faulted, User Disabled, or None.
<b>EXHAUST/RETURN FAN VFD</b>	This identifies speed output in percentage that is being sent to the exhaust or return fan VFD.
<b>FAN SPEED SETP FOR HIGH SAT</b>	This parameter is programmed through the SETPOINTS key. When the supply fan speed is equal to or less than this value the Active Supply Air Temperature Setpoint on a Variable Air Volume Unit will be set to the SAT Setpoint High Limit.
<b>FAN SPEED SETP FOR LOW SAT</b>	This parameter is programmed through the SETPOINTS key. When the supply fan speed is equal to or greater than this value the Active Supply Air Temperature Setpoint on a Variable Air Volume Unit will be set to the SAT Setpoint Low Limit.
<b>FILTER STATUS</b>	This is status of the unit filters. A differential pressure switch must be installed to measure the pressure drop across the filters. When the filters are dirty the switch closes sending a Binary signal to the Unit Controller. The User Interface display will show Okay or Change.
<b>FLEX EVAP TEMP ACTIVE SP</b>	This is the active evaporator temperature setpoint that the Unit Controller is trying to control to. This value is used when a FlexSys unit is in the Occupied Cooling With Bypass mode.
<b>FLEX EVAP TEMP CURRENT</b>	This is the actual air temperature leaving the evaporator coil of a FlexSys unit.
<b>FURNACE 1 MODE</b>	This is the current status of the first heat exchanger section of a staged gas heat unit. The User Interface will display Off, Purge, Ignition, On-Low, On-High, Safety Trip, Safety Fault, Safety Lockout, or Fault- I/O.

**TABLE 40 – DEFINITIONS (CONT'D)**

<b>FURNACE 1A MODE</b>	This is the current status of the modulating section of the modulating gas heat furnace. The User Interface will display Off, Purge, Ignition, On-Low, On-High, Safety Trip, Safety Fault, Safety Lockout, or Fault- I/O.
<b>FURNACE 1B MODE</b>	This is the current status of the non-modulating section of the modulating gas heat furnace. The User Interface will display Off, Purge, Ignition, On, Safety Trip, Safety Fault, Safety Lockout, or Fault- I/O.
<b>FURNACE 2 MODE</b>	This is the current status of the second heat exchanger section of a staged gas heat unit. The User Interface will display Off, Purge, Ignition, On-Low, On-High, Safety Trip, Safety Fault, Safety Lockout, or Fault- I/O.
<b>FURNACE 3 MODE</b>	This is the current status of the third heat exchanger section of a staged gas heat unit. The User Interface will display Off, Purge, Ignition, On-Low, On-High, Safety Trip, Safety Fault, Safety Lockout, or Fault- I/O.
<b>GAS HEAT CAPACITY</b>	This parameter is programmed through the OPTIONS key. This parameter is used to identify the gas heat capacity installed in the unit. The options are 375 MBH, 750 MBH, or 1125 MBH.
<b>HEAT ENTERING TEMP</b>	This is the temperature of the supply air entering the staged heat section. This value is used to initiate and terminate Supply Air Tempering when Staged Heat is installed.
<b>HEAT LIMIT TEMPERATURE</b>	This parameter is programmed through the SETPOINTS key. This value determines the maximum allowable Supply Air Temperature when heating is installed. If the temperature goes above this setting the heat section will be shut down.
<b>HEATING CONTROL OFFSET</b>	This is the control band the unit is trying to maintain. The control band is the Active Setpoint +/- the Heating Control Offset. If the temperature is below this band, additional heating is required, if the temperature is above this band heating is decreased.
<b>HEATING SAT</b>	This parameter is programmed through the SETPOINTS key. On a VAV or FlexSys unit this becomes the Active Supply Air Temperature Setpoint for heating operation. The Unit Controller controls the heating option to try and maintain this temperature.
<b>HEATING SYS STATUS</b>	This is the current operating mode of the Heating Section. The display will show Normal - Active, Normal - Inactive, Safety Trip, Safety Fault, Safety Lockout, User Disabled, or None.
<b>HEATING SYSTEM TYPE</b>	This parameter is programmed through the OPTIONS key. This parameter is used to identify the type of heat installed in the unit. The options are None, Electric, Stage Gas, Modulating Gas, Hot Water / Steam.
<b>HW / STEAM FRZ STAT</b>	This is the status of the hydronic heat freeze-stat. This is done through a Binary input to the Unit Controller. The switch is open for normal operation and closed on failure. The User Interface will indicate OK or FAULTED.
<b>HW / STEAM HEAT - VALVE POS</b>	This is the output from the Unit Controller to the hydronic valve as percent open.
<b>HW VALVE ACTION</b>	This parameter is programmed through the PROGRAM key. This parameter controls the output to the hydronic modulating valve. When the parameter is set to DIRECT the output is 0 volts for off and 10 volts for full capacity. When the parameter is set to REVERSE the output is 10 volts for off and 0 volts for full capacity.
<b>MAXIMUM BYPASS</b>	This parameter is programmed through the SETPOINTS key. It establishes the maximum allowable position of the bypass damper in a FlexSys unit.
<b>MECH CLG LOCKOUT TEMP</b>	This parameter is programmed through the SETPOINTS key. When the outdoor temperature is equal to or less than this temperature, the Unit Controller will prevent the compressors from operating.
<b>MINIMUM OA FLOW SETPOINT</b>	This parameter is programmed through the SETPOINTS key. When air measurement stations are installed and the unit is not in the Occupied mode, this is the minimum allowable airflow.
<b>MX SUPPLY AIR TEMP</b>	This parameter is programmed through the SETPOINTS key. This becomes the Active Supply Air Temperature Setpoint for a FlexSys unit when it is in the Occupied Cooling Without Bypass mode.
<b>FURNACE 1A MODE APRX RATE</b>	This is the approximate firing rate of the modulating gas heat section in MBH.
<b>FURNACE 1A MODE RELATIVE</b>	This is the output from the Unit Controller to the modulating gas heat section in percent of full capacity.

**TABLE 40 – DEFINITIONS (CONT'D)**

<b>MORNING WARM UP</b>	This parameter is programmed through the PROGRAM key. This tells the Unit Controller if the Morning Warmup option is available or not. When it is programmed to USER ENABLED, Morning Warm Up is available to be used. When it is programmed to USER DISABLED, Morning Warm Up is unavailable.
<b>MORNING WARM UP MAX TIME</b>	This parameter is programmed through the SETPOINTS key. This value is the maximum time the Unit Controller will allow for Morning Warm Up when the unit is in the Adaptive Morning Warm Up mode. If the derived Morning Warm Up Opt Time exceed this time the Morning Warm Up Max Time will be used.
<b>MORNING WARM UP OPT TIME</b>	This is the average of the previous three days Warm Up times plus 10 minutes. This value will be used to determine the Morning Warm Up start time for the next day when the unit is in the Adaptive Morning Warm Up mode.
<b>NIGHT SET BACK</b>	This parameter is programmed through the PROGRAM key. This parameter allows the user to enable or disable Night Set Back. If this parameter is disabled Unoccupied Heating will not be available. The two parameters to choose from are USER ENABLED or USER DISABLED.
<b>OA DAMPER MAXIMUM POSITION</b>	This parameter is programmed through the SETPOINTS key. This establishes the maximum amount of ventilation air to be used in a Demand Ventilation situation.
<b>OA DAMPER MINIMUM POSITION</b>	This parameter is programmed through the SETPOINTS key. This establishes the minimum amount of ventilation air to be used when the unit is in the Occupied mode.
<b>OA DAMPER POSITION ACTIVE SP</b>	This is the damper position setpoint, in percent open, the Unit Controller is trying to maintain.
<b>OA DAMPER POSITION CURRENT</b>	This is the actual output, in percent open to the outdoor air damper.
<b>OUTSIDE AIR ENTHALPY</b>	This indicates the total heat content of the outdoor air.
<b>OUTSIDE AIR HUMIDITY</b>	This is the outdoor air relative humidity.
<b>OUTSIDE AIR TEMP</b>	This is the outdoor air dry bulb temperature.
<b>OAT SETPOINT FOR HIGH SAT</b>	This parameter is programmed through the SETPOINTS key. When the outdoor temperature is equal to or less than this temperature the Active Supply Air Temperature Setpoint on a Variable Air Volume Unit will be set to the SAT HIGH SETPOINT.
<b>OAT SETPOINT FOR LOW SAT</b>	This parameter is programmed through the SETPOINTS key. When the outdoor temperature is equal to or greater than this temperature the Active Supply Air Temperature Setpoint on a Variable Air Volume Unit will be set to the SAT LOW SETPOINT.
<b>OUTSIDE AIR ENTHALPY SETPOINT</b>	This parameter is programmed through the SETPOINTS key and is the upper limit of outdoor enthalpy that can be used for economizer operation. If the outdoor air enthalpy is above this value, the economizer is made inactive.
<b>OUTSIDE AIR FLOW ACTIVE SP</b>	This is the airflow setpoint that the Unit Controller is trying to maintain.
<b>OUTSIDE AIR MAXIMUM FLOW</b>	This parameter is programmed through the SETPOINTS key. When air measurement stations are installed and the unit is in the Demand Ventilation mode, this is the maximum allowable airflow value.
<b>OUTSIDE AIR MINIMUM FLOW</b>	This parameter is programmed through the SETPOINTS key. When air measurement stations are installed and the unit is in the Demand Ventilation mode, this is the minimum airflow value.
<b>POWER EXHAUST TYPE</b>	This parameter is programmed through the OPTIONS key and tells the Unit Controller what type of Exhaust is installed. The choices are None, On-Off Damper Cntrl, On-Off Press Cntrl, Modulate Damper VFD, Return Fan W/Exh, or Return Fan W/O Exh.
<b>PRESS TRANS PKG</b>	This parameter is programmed through the OPTIONS key. This identifies to the Unit Controller which of the compressor systems are configured with suction and discharge pressure transducers. The options are None, Sys 1; Sys 1, 2; or Sys 1, 2 and 3.
<b>PRESSURE DISCHARGE*</b>	This is the discharge pressure and is shown for each compressor system if pressure transducers are installed and configured for the system.
<b>PRESSURE SUCTION*</b>	This is the suction pressure and is shown for each compressor system if pressure transducers are installed and configured for the system.

**TABLE 40 – DEFINITIONS (CONT'D)**

<b>PUMPDOWN</b>	This parameter is programmed through the PROGRAM key. If Pumpdown is USER ENABLED at the end of the compressor system cycle the solenoid valve to the expansion valves will close and the compressor will continue to operate for 30 seconds or until the low pressure cutout opens. This removes the refrigerant from the low side of the system. The choices are USER ENABLED or USER DISABLED. If Pumpdown is ENABLED all compressor system will use Pumpdown.
<b>RETURN AIR ENTHALPY</b>	This is the total heat content of the return air.
<b>RETURN AIR HUMIDITY</b>	This is the return air relative humidity.
<b>RETURN AIR TEMP</b>	This is the return air dry bulb temperature.
<b>RETURN AIR TEMP CURRENT</b>	This is the temperature of the return air entering the unit.
<b>RAT HEATING SETPOINT</b>	On a VAV or FlexSys unit, the Unit Controller monitors the RAT HEATING SETPOINT. When the return air temperature is 0.5 °F below this value the control switches into the Occupied Heating mode.
<b>RAT COOLING SETPOINT</b>	On a VAV or FlexSys unit, the Unit Controller monitors the RAT COOLING SETPOINT. When the return air temperature is 0.5 °F above this value the control switches into the Occupied Cooling mode.
<b>RAT SETPOINT FOR HIGH SAT</b>	This parameter is programmed through the SETPOINTS key. When the Return Air Temperature is equal to or LESS than this temperature the Active Supply Air Temperature Setpoint on a Variable Air Volume Unit will be set to the SAT HIGH SETPOINT.
<b>RAT SETPOINT FOR LOW SAT</b>	This parameter is programmed through the SETPOINTS key. When the Return Air Temperature is equal to or greater than this temperature the Active Supply Air Temperature Setpoint on a Variable Air Volume Unit will be set to the SAT LOW SETPOINT.
<b>READY TO RUN COMP A</b>	This means the minimum OFF time has been achieved and all the safety circuits are closed and compressor A of the system is ready to be energized. The User Interface will display either YES or NO.
<b>READY TO RUN COMP B</b>	This means the minimum OFF time has been achieved and all the safety circuits are closed and compressor B of the system is ready to be energized. The User Interface will display either YES or NO.
<b>READY TO STOP COMP A</b>	This means the minimum ON time has been achieved and compressor A of the system is ready to be de-energized. The User Interface will display either YES or NO.
<b>READY TO STOP COMP B</b>	This means the minimum ON time has been achieved and compressor B of the system is ready to be de-energized. The User Interface will display either YES or NO.
<b>REFRIGERANT TYPE</b>	This parameter is programmed through the OPTIONS key and identifies the type of refrigerant in the unit.
<b>RETURN AIR BYPASS ACTIVE SP</b>	This is the position of the bypass damper by percent open the Unit Controller uses as the bypass setpoint on a FlexSys unit.
<b>RETURN AIR BYPASS CURRENT</b>	This is the position of the by-pass damper by percent open the Unit Controller uses as the Active Bypass percent setpoint on a FlexSys unit.
<b>RETURN FAN PRESSURE ACTIVE SP</b>	This is the current mixed air chamber pressure that the Unit Controller is trying to maintain.
<b>RETURN FAN PRESS CURRENT</b>	This is the actual pressure in the mixed air chamber of the unit.
<b>RETURN FAN OUTPUT</b>	This is the Binary output from the Unit Controller to the Return Fan control system.
<b>RETURN FAN STATUS</b>	This is a Binary input into the Unit Controller that identifies the Return Fan is functioning.
<b>SAFETY INPUT LPCO</b>	This is the Binary input to the Unit Controller from the Low Pressure Cutout safety circuit. ON means the safety circuit is normal and FAULTED means it has faulted. This parameter will be shown for each compressor system.
<b>SAFETY INPUT CHAIN</b>	This is the Binary input to the Unit Controller from the Compressor Safety Circuit Chain. This includes the high pressure cutout, compressor motor protector, and the external overload or circuit breaker. ON means the safety circuit is normal and FAULTED means it has faulted. This parameter will be shown for each compressor system.

**TABLE 40 – DEFINITIONS (CONT'D)**

<b>SAT RESET METHOD</b>	This parameter is programmed through the OPTIONS key and identifies the Supply Air Temperature reset method being used on a Variable Air Volume Unit. The choices are Hardwired, Outside Air, Return Air, or Supply Fan Speed.
<b>SAT HIGH SETPOINT</b>	This parameter is programmed through the SETPOINTS key. This establishes the maximum Active Supply Air Temperature to be used in a Variable Air Volume Unit.
<b>SAT LOW SETPOINT</b>	This parameter is programmed through the SETPOINTS key. This establishes the minimum Active Supply Air Temperature to be used in a Variable Air Volume Unit.
<b>SENSOR / MISC STATUS</b>	This is the current status of the Sensors. The display will show Normal, Warning, Safety Trip, Safety Fault, or Safety Lockout.
<b>SINGLE ZONE MINIMUM VAV SPEED</b>	This parameter provides the minimum speed of the Supply Fan during SZVAV operation.
<b>SMOKE PURGE SEQ 1</b>	This parameter is programmed through the OPTIONS key. This allows the user to select which of the three smoke purge sequences to use a sequence 1, Purge, Pressurization, or Evacuation. Smoke Purge Sequence 1 is energized through a Binary input to the Unit Controller.
<b>SMOKE PURGE SEQ 2</b>	This parameter is programmed through the OPTIONS key. This allows the user to select which of the three smoke purge sequences to use a sequence 2, Purge, Pressurization, or Evacuation. Smoke Purge Sequence 2 is energized through a Binary input to the Unit Controller.
<b>SMOKE PURGE SEQ 3</b>	This parameter is programmed through the OPTIONS key. This allows the user to select which of the three smoke purge sequences to use a sequence 3, Purge, Pressurization, or Evacuation. Smoke Purge Sequence 3 is energized through a Binary input to the Unit Controller.
<b>1ST STAGE COOLING SETPOINT</b>	This parameter is programmed through the SETPOINTS key. This value is used in a Constant Volume unit as the Active SAT Setpoint for 1st Stage cooling operation.
<b>1ST STAGE HEATING SETPOINT</b>	This parameter is programmed through the SETPOINTS key. This value is used in a Constant Volume unit as the Active SAT Setpoint for 1st Stage heating operation.
<b>2ND STAGE 2 COOLING SETPOINT</b>	This parameter is programmed through the SETPOINTS key. This value is used in a Constant Volume unit as the Active SAT Setpoint for 2nd Stage cooling operation.
<b>2ND STAGE 2 HEATING SETPOINT</b>	This parameter is programmed through the SETPOINTS key. This value is used in a Constant Volume unit as the Active SAT Setpoint for 2nd Stage heating operation.
<b>STAGED HEAT STATUS STGS ON</b>	This identifies the number of stages of gas or electric heat that the Unit Controller has energized.
<b>STAGED HEAT STATUS STGS AVAIL</b>	This identifies the number of stages of gas or electric heat that are available.
<b>SUCTION TEMP</b>	This is the temperature of the suction line leaving the evaporator coil and will be shown for each system. This value is monitored and used to prevent liquid refrigerant from being returned to the compressor.
<b>SUP AIR TEMPERING</b>	This parameter is programmed through the PROGRAM key. This parameter is used to allow the heat to operate when the unit is in the Occupied Standby mode to temper the ventilation air entering the space. The choices are USER ENABLED or USER DISABLED.
<b>SUPPLY AIR TEMP ACTIVE SP</b>	This is the Supply Air Temperature the Unit Controller is trying to maintain.
<b>SUPPLY AIR TEMP CURRENT</b>	This is the current Supply Air Temperature supplied by the unit.
<b>SUPPLY FAN OUTPUT</b>	This is the Binary output from the Unit Controller to the Supply Fan control system.
<b>SUPPLY FAN OUTPUT PROOF</b>	This is a Binary input into the Unit Controller that identifies the Supply Fan is functioning.
<b>SUPPLY FAN VFD SPEED</b>	This indicates the output, in percent, to the Supply Fan VFD.
<b>SUPPLY SYS STATUS</b>	This is the active status of the Supply System, display will show Normal- Active; Normal-Inactive; Safety Trip, Safety Fault, or Safety Lockout.

**TABLE 40 – DEFINITIONS (CONT'D)**

<b>SYSTEM UNLOADING PRESSURE</b>	This parameter is programmed through the SETPOINTS key. If two compressors of the system are operative and the discharge pressure is equal to or greater than this value the Unit Controller will turn off one of the compressors. This feature is only operative when a discharge pressure transducer is installed in the compressor system.
<b>TEMPERATURE SUPERHEAT</b>	This is calculated for each compressor system that has a suction line pressure transducer installed and configured. This is the refrigerant evaporator superheat leaving the evaporator coil.
<b>UNDERFLOOR AIR HUMIDITY</b>	This is the humidity level under the floor of a FlexSys installation.
<b>UNDERFLOOR AIR TEMP</b>	This is the temperature of the air in the underfloor space.
<b>UNDERFLOOR SLAB DEW POINT</b>	This is the dewpoint of the air beneath the floor of a FlexSys installation.
<b>UNDERFLOOR SLAB TEMP</b>	This is the temperature of the slab beneath the floor of a FlexSys installation.
<b>UNIT INSTALLED ALTITUDE</b>	This parameter is programmed through the SETPOINTS key. This is the altitude at which the unit is installed. This is used in the calculation of an airflow correction factory when air measuring stations are installed.
<b>UNIT SIZE</b>	This parameter is programmed through the OPTIONS key and identifies the size of the unit.
<b>UNIT TYPE</b>	This parameter is programmed through the OPTIONS key and identifies the type of unit. The choices are Constant Volume, Variable Volume, or FlexSys.
<b>UNIT-OVERALL STATUS</b>	This is the active status of the Unit. The display will show Local Stop, Run, Unit Trip, Unit Fault, Unit Lockout, SMK Purge # - Press, SMK Purge #-Purge, or Smk Purge #-Evac.
<b>VENT SYS STATUS</b>	This is the active status of the Ventilation System. The display will show Normal- Active, Normal-Inactive, Safety Trip, Safety Fault, Safety Lockout, User Disabled, or None.
<b>VENTILATION CONTROL</b>	This parameter is programmed through the OPTIONS key and identifies whether the unit will operate with a Fixed Minimum or Demand ventilation system.
<b>VENTILATION DEMAND</b>	This is the output in percent to the outside air damper when the unit is operating in the Demand Ventilation mode.
<b>ZONE TEMP OCC ZONE COOLING SETPOINT</b>	This parameter is programmed using the SETPOINTS key. This is the temperature that the Unit Controller compares the actual space temperature to, to decide when to switch into the Occupied Cooling Mode.
<b>ZONE TEMP OCC ZONE HEATING SETPOINT</b>	This parameter is programmed using the SETPOINTS key. This is the temperature that the Unit Controller compares the actual space temperature to, to decide when to switch into the Occupied Heating Mode.
<b>ZONE TEMP UNOCC ZONE COOLING SETPOINT</b>	This parameter is programmed using the Setpoints key. This is the temperature that the Unit Controller compares the actual space temperature to, to decide when to switch into the Unoccupied Cooling Mode.
<b>ZONE TEMP UNOCC ZONE HEATING SETPOINT</b>	This parameter is programmed using the Setpoints key. This is the temperature that the Unit Controller compares the actual space temperature to, to decide when to switch into the Unoccupied Heating Mode.
<b>ZONE TEMP CURRENT</b>	This is the temperature in the conditioned space.

\* May be 1, 2, or 3



## SECTION 8 – SERVICE

### ANALOG INPUT OPERATION

This section describes the control operation of the 29 analog inputs. These inputs are used by the control to monitor and respond to unit temperatures, pressures, enthalpy, etc. The location of each of these connections on the Unit Controller is contained in *Table 36 on page 120*. Notice that the ID gives the jack connection designated as “J” and then the identifying number of the connector, followed by a – and then the pin number of the connector. For example, the SUPPLY AIR TEMPERATURE analog input would be found at J1-1. This is connector J1 – Pin 1. As the Unit Controller board is positioned in the control box the top row of the J series connectors is the input, the middle row is the common, and the bottom row is the 5VDC input to the sensor. Also the pin in the right hand top corner is pin 1.

### Temperature Sensors

The temperature sensors are all 10K Type III Thermistors. The relationship between the temperature and the voltage output and resistance is contained in Table 40. The following analog input are of this type: Supply Air Temperature, Heat Entering Temp, Flex Evap Temp, Outside Air Temp, Return Air Temp, Suction Temp #1, Suction Temp #2, Suction Temp #3, Zone Temp, and Under Floor Temp.

**TABLE 41 - TEMPERATURE SENSOR RESISTANCE**

°F	VOLTAGE	RESISTANCE	°C
-25	0.49	139,639	-30.6
-20	0.53	127,453	-28.9
-15	0.60	109,624	-26.1
-10	0.69	94,519	-23.34
-5	0.78	81,665	-20.55
0.0	0.88	70,750	-17.78
5	0.98	61,418	-15.00
10	1.10	53,426	-12.22
15	1.22	46,582	-9.44
20	1.35	40,703	-6.67
25	1.48	35,639	-3.89
30	1.62	31,269	-1.11
35	1.77	27,490	1.67
40	1.91	24,219	4.44
45	2.06	21,377	7.22
50	2.21	18,900	10.00
55	2.36	16,744	12.78

### Duct Pressure Transducer

The Duct Pressure Transducer is located in the return air section of the unit. The purpose of the transducer is to sense and convert the static pressure in the supply-side of the duct to a 0 to 5VDC voltage. The DC voltage is sent to the Unit Controller and compared against the “DUCT STATIC PRESS ACTIVE SP”. The transducer is factory wired, but pneumatic tubing must be field supplied and installed (refer to *SECTION 2 – INSTALLATION*). The duct static pressure transducer measures differential pressure between the pressure in the duct and atmospheric pressure. When verifying transducer operation, the technician must insert a tee in the pneumatic tubing and connect a manometer to the tee to verify the pressure being applied to the transducer. Once this pressure is known, a comparison can be made of the duct pressure vs. output VDC from the transducer. *Table 42 on page 170* shows the relationship between the pressure applied to the duct pressure transducer and the output voltage. The output is linear between 0" W.C. and the SPAN. The “DUCT PRESS TRANSDUCER SPAN” can be set to 1.25, 2.5 or 5" W.C.

°F	VOLTAGE	RESISTANCE	°C
60	2.51	14,681	15.56
65	2.66	13,216	18.33
70	2.80	11,771	21.11
75	2.94	10,502	23.89
80	3.08	9,388	26.67
85	3.21	8,404	29.45
90	3.33	7,537	32.22
95	3.45	6,770	35.0
100	3.56	6,090	37.78
105	3.66	5,487	40.56
110	3.76	4,951	43.34
115	3.85	4,475	46.11
120	3.94	4,050	48.89
125	4.02	3,671	51.66
130	4.09	3,332	54.44
135	4.16	3,029	57.22

**TABLE 42 - DUCT PRESSURE TRANSDUCER**

1.25" W.C. SPAN DIFFERENTIAL INPUT PRESS	2.5" W.C. SPAN DIFFERENTIAL INPUT PRESS	5.0" W.C. SPAN DIFFERENTIAL INPUT PRESS	VOLTAGE VDC
0.125	0.25	0.5	0.50
0.25	0.50	1.0	1.00
0.375	0.75	1.50	1.50
0.50	1.00	2.00	2.00
0.625	1.25	2.50	2.50
0.75	1.50	3.00	3.00
0.875	1.75	3.50	3.50
1.00	2.00	4.00	4.00
1.125	2.25	4.50	4.50
1.25	2.50	5.00	5.00

**Building Pressure Transducer**

The Building Pressure Transducer is located in the return air section of the unit. The purpose of the transducer is to sense and convert the static pressure in the building to a 0 to 5VDC voltage. The DC voltage is then sent to the Unit Controller and compared against the *"BUILDING PRESSURE ACTIVE SETPOINT"*. The transducer is factory wired, but pneumatic tubing must be field supplied and installed (refer to *SECTION 2 – INSTALLATION*). The Building Pressure Transducer measures differential pressure in the building and atmospheric pressure. When verifying transducer operation, the technician can insert a tee into the pneumatic tubing and connect a manometer to the tee to verify the pressure being applied to the transducer. Once this pressure is known, a comparison can be made of the building pressure vs. output VDC from the transducer. A practical and quick check of this transducer can also be accomplished by removing the pneumatic tubing lines from both the low and high side connections on the transducer. Since both of the inputs will now be exposed to the same pressure, the differential pressure will be zero, and the output 2.5VDC according to *Table 43 on page 170*.

**TABLE 43 - BUILDING PRESSURE  
TRANSDUCER OUTPUT**

DIFFERENTIAL INPUT PRESSURE - "W.C.	OUPTUT VOLTAGE - VDC
-0.50	0.00
-0.40	0.50
-0.30	1.00
-0.20	1.50
-0.10	2.00
0.00	2.50
0.10	3.00
0.20	3.50
0.30	4.00
0.40	4.50
0.50	5.00

**Return Fan Pressure Transducer**

If the unit is order with the Return Fan Option the unit will have a Return Fan Pressure Transducer. The transducer is mounted in the return compartment and compares the pressure in the return air compartment to atmospheric pressure. The Unit Controller varies the speed of the Return Fan in order to maintain the correct differential pressure in the return compartment. When verifying transducer operation, the technician can insert a tee into the pneumatic tubing and connect a manometer to the tee to verify the pressure being applied to the transducer. Once this pressure is known, a comparison can be made of the return compartment pressure vs. output VDC from the transducer. A practical and quick check of this transducer can also be accomplished by removing the pneumatic tubing lines from both the low and high side connections on the transducer. Since both of the inputs will now be exposed to the same pressure, the differential pressure will be zero, and the output 2.5VDC according to *Table 44 on page 170*.

**TABLE 44 - RETURN FAN PRESSURE  
TRANSDUCER OUTPUT**

DIFFERENTIAL INPUT PRESSURE - "W.C.	OUPTUT VOLTAGE - VDC
-1.00	0.00
-0.80	0.50
-0.60	1.00
-0.40	1.50
-0.20	2.00
0.00	2.50
0.20	3.00
0.40	3.50
0.60	4.00
0.80	4.50
1.00	5.00

### Discharge Pressure Transducer

The discharge Pressure Transducer is located in the common discharge line of the tandem compressors for each refrigerant circuit. The purpose of this transducer is to sense and convert the discharge pressure into a DC voltage. The DC voltage is then sent to the Unit Controller where it is used to control the number of condenser fan when the unit is in cooling operation. The discharge pressure value, in PSIG, is displayed by the User Interface.

The Discharge Transducer has a range of 0 to 500 PSIG, with a linear output of 0 to 5VDC. *Table 45 on page 171* illustrates the DC volt output from the transducer for a given discharge pressure.

### Suction Pressure Transducer

The optional suction pressure transducer is located in the common suction line of the tandem compressors for each refrigerant circuit. The purpose of the transducer is to sense and convert the suction pressure to a DC voltage. The DC voltage is then sent to the Unit Controller where it is displayed by the User Interface. When this option is installed the Unit Controller will also calculate and display the Evaporator Superheat value for the system.

The Suction Transducer has a range of 0 to 200 PSIG, with a linear output of 0 to 5VDC. *Table 45 on page 171* illustrates the DC volt output from the transducer for a given suction pressure.

**TABLE 45 - PRESSURE TRANSDUCERS**

SUCTION TRANSDUCER		DISCHARGE TRANSDUCER	
PRESSURE PSIG	VOLTAGE VDC	PRESSURE PSIG	VOLTAGE VDC
0	0.50	0	0.50
25	1.00	50	1.00
50	1.50	100	1.50
75	2.00	150	2.00
100	2.50	200	2.50
125	3.00	250	3.00
150	3.50	300	3.50
175	4.00	350	4.00
200	4.50	400	4.50

## Humidity Sensors

The humidity sensor outputs a 0 to 5VDC in response to the relative humidity sensed. An outdoor air humidity sensor is used whenever the economizer is configured for single or dual enthalpy. A return air humidity sensor is used whenever the economizer is configured for dual enthalpy. A humidity sensor is also used to monitor the humidity in the space between the slab and raised floor system used for FlexSys applications. *Table 46 on page 172* gives the relationship between the voltage output of the humidity sensor and the % relative humidity.

## CO<sub>2</sub> Sensor

Two CO<sub>2</sub> sensors are used in conjunction with the “DEMAND VENTILATION” option. In “DEMAND VENTILATION” the Unit Controller monitors the CO<sub>2</sub> level of the outdoor air and the CO<sub>2</sub> level in the conditioned space and varies the amount of ventilation air based on the relationship between these two values. *Table 47 on page 172* gives the volts DC output for a given CO<sub>2</sub> level.

## Furnace Status Input

The Unit Controller monitors the operation of the Staged and Modulating Gas Heat sections and displays the status through the STATUS screen of the User Interface. The operation of each of the gas heat sections is monitored by a multiplexer installed in the gas heat section. When a gas heat section is energized, it sends a 24-volt signal to the multiplexer. The multiplexer takes the five “ON”/“OFF” inputs and converts them into a 0 to 5VDC signal that is sent to the Unit Controller. The Unit Controller then decodes this analog input and displays the furnace section status. *Table 48 on page 173 and Table 49 on page 173* show the relationship between the DC voltage and the furnace operation status.

**TABLE 46 - HUMIDITY SENSOR OUTPUTS**

% RELATIVE HUMIDITY	OUTPUT VOLTAGE VDC	% RELATIVE HUMIDITY	OUTPUT VOLTAGE VDC
5	0.25	55	2.75
10	0.50	60	3.00
15	0.75	65	3.25
20	1.00	70	3.50
25	1.25	75	3.75
30	1.50	80	4.00
35	1.75	85	4.25
40	2.00	90	4.50
45	2.25	95	4.75
50	2.50	100	5.00

**TABLE 47 - CO<sub>2</sub> SENSOR OUTPUT**

PPM CO <sub>2</sub>	OUTPUT VOLTAGE VDC	PPM CO <sub>2</sub>	OUTPUT VOLTAGE VDC
80	0.20	1120	2.80
160	0.40	1200	3.00
240	0.60	1280	3.20
320	0.80	1360	3.40
400	1.00	1440	3.60
480	1.20	1520	3.80
560	1.40	1600	4.00
640	1.60	1680	4.20
720	1.80	1760	4.40
800	2.00	1840	4.60
880	2.20	1920	4.80
960	2.40	2000	5.00
1040	2.60		

**TABLE 48 - FURNACE STATUS INPUT MODULATING GAS HEAT**

MIN VOLTS DC	MAX VOLTS DC	MODULATING FURNACE 1A STATUS	FURNACE 1A HIGH STATUS	FURNACE 2 STATUS	FURNACE 3 STATUS	FURNACE 1B STATUS
0.086	0.166	OFF	OFF	OFF	OFF	OFF
0.224	0.313	ON	OFF	OFF	OFF	OFF
0.361	0.461	OFF	ON	OFF	OFF	OFF
0.499	0.609	ON	ON	OFF	OFF	OFF
0.637	0.756	OFF	OFF	ON	OFF	OFF
0.774	0.904	ON	OFF	ON	OFF	OFF
0.912	1.051	OFF	ON	ON	OFF	OFF
1.050	1.199	ON	ON	ON	OFF	OFF
1.187	1.346	OFF	OFF	OFF	ON	OFF
1.325	1.494	ON	OFF	OFF	ON	OFF
1.463	1.641	OFF	ON	OFF	ON	OFF
1.600	1.789	ON	ON	OFF	ON	OFF
1.738	1.936	OFF	OFF	ON	ON	OFF
1.876	2.084	ON	OFF	ON	ON	OFF
2.013	2.231	OFF	ON	ON	ON	OFF
2.151	2.379	ON	ON	ON	ON	OFF
2.289	2.526	OFF	OFF	OFF	OFF	ON
2.426	2.674	ON	OFF	OFF	OFF	ON
2.564	2.821	OFF	ON	OFF	OFF	ON
2.702	2.969	ON	ON	OFF	OFF	ON
2.839	3.116	OFF	OFF	ON	OFF	ON
2.977	3.264	ON	OFF	ON	OFF	ON
3.115	3.411	OFF	ON	ON	OFF	ON
3.252	3.559	ON	ON	ON	OFF	ON
3.390	3.706	OFF	OFF	OFF	ON	ON
3.528	3.854	ON	OFF	OFF	ON	ON
3.665	4.001	OFF	ON	OFF	ON	ON
3.803	4.149	ON	ON	OFF	ON	ON
3.941	4.296	OFF	OFF	ON	ON	ON
4.078	4.444	ON	OFF	ON	ON	ON
4.216	4.592	OFF	ON	ON	ON	ON
4.354	4.739	ON	ON	ON	ON	ON

**8**

**TABLE 49 - FURNACE STATUS INPUT STAGED GAS HEAT**

MIN VOLTS DC	MAX VOLTS DC	FURNACE 1 STATUS	FURNACE 2 STATUS	FURNACE 3 STATUS
0.086	0.166	OFF	OFF	OFF
0.224	0.313	ON	OFF	OFF
0.361	0.461	OFF	ON	OFF
0.499	0.609	ON	ON	OFF
0.637	0.756	OFF	OFF	ON
0.774	0.904	ON	OFF	ON
0.912	1.051	OFF	ON	ON
1.050	1.199	ON	ON	ON

## FAULTS

A fault is defined as an abnormal condition, which results in the shutdown of an operating system or the complete unit. The presence of a fault condition indicates a situation in which possible damage to the unit may occur if the unit or system were allowed to continue to operate. There are four types of faults.

- **UNIT LOCKOUT** – The complete unit is shutdown and locked out. A manual reset is required to restart the unit after the fault has been corrected.
- **SYSTEM LOCKOUT** – One of the compressor systems or other component is shutdown and locked out. A manual reset is required to restart the system after the fault has been corrected.
- **UNIT AUTO RESET** – The complete unit is shutdown but the unit will restart automatically when the fault condition is cleared.
- **SYSTEM AUTO RESET** – One of the compressor systems or other component is shut down but the system or component will restart automatically when the fault condition is cleared.

A UNIT LOCKOUT can be reset by turning the “LOCAL STOP” switch OFF for 5 seconds and then back ON. If the cause of the lockout has been corrected the unit will reset and begin proper operation.

A SYSTEM LOCKOUT except for COMPR # LOCKOUT and COMPR # LPCO SAFETY LOCKOUT can be reset by turning the “LOCAL STOP” switch OFF for 5 seconds and then back ON. A COMPR # LOCKOUT and COMPR # LPCO SAFETY LOCKOUT must be reset by entering the OPTIONS key and the COMPRESSOR SYSTEMS # subsection, which has the lockout. Then use the up and down arrow key to go to COMP SYS # STATUS. The current status will be LOCKOUT. Press the check key (✓) and use the right arrow key to change LOCKOUT to RUN.

In addition to faults the User Interface will also display warnings. A warning is defined as an abnormal condition under which the unit continues to operate. Warnings will not require the unit to shut down; however, they may require the Unit Controller to disable certain functions that may result in the unit operating less efficiently or eliminate certain features.

Table 52 on page 181 lists the faults / warnings that will be displayed under the STATUS and HISTORY keys of the User Interface. When a fault is present line

two of the effected STATUS screen display (UNIT-OVERALL STATUS, COMPRESSOR SYSTEM 1, COMPRESSOR SYSTEM 2, COMPRESSOR SYSTEM 3, HEATING SYSTEM, ECONOMIZER SYSTEM, SUPPLY SYSTEM, EXHAUST SYSTEM, VENTILATION SYSTEM, or SENSOR / MISC STATUS) will change nomenclature to indicate a WARNING, SAFETY TRIP, SAFETY FAULT, or SAFETY LOCKOUT is present. A fault / warning description, method of reset and conditions under which the information is displayed is also contained in the table. Additional information for each of the faults is contained under their respective segment of SECTION 5 – SEQUENCE OF OPERATION located in this IOM.

When a fault is declared, the Unit Controller will record the time of occurrence, the date of occurrence, and a complete unit snapshot at the time of each occurrence in the HISTORY buffer. This data can be retrieved using the HISTORY key of the User Interface.

The HISTORY buffer stores the data from the last ten faults from the most recent (HISTORY 01) to the oldest (HISTORY 10). No fault HISTORY is eliminated once recorded other than being “pushed off” of the end of the list by a new fault when the buffer becomes full.

Warnings are only displayed in the HISTORY buffer while they are active. When the problem that generated the WARNING is corrected the record is removed from the buffer. The Unit Controller does not record the time of occurrence, the date of occurrence, or a complete unit snapshot at the time of occurrence for a WARNING.

The HISTORY buffer is password protected and a level 2 password must be entered in order to view the data.

When the HISTORY key is pressed, the password prompt will appear. After the proper level 2 password has been entered the screen will show the first active warning. If there are no active warnings present, the first fault will be displayed. If there are no faults in the HISTORY buffer, the screen will display “NO FAULT”. For menu navigation and display description, see *History on page 128* for additional information on how to navigate through the HISTORY menu.

In addition to the items listed in Table 52 on page 181, the following items listed below are contained under the HISTORY key.

**“COMPRESSOR SYSTEM (1,2, OR 3) CLEAR”** - Whenever there is a compressor safety trip the Unit Controller initiates the **“COMPR STATUS CLEAR TIME (1,2, OR 3)”** timer. The Unit Controller records the time it takes for the trip to clear. When the fault clears **“COMPRESSOR SYSTEM (1,2, OR 3) CLEAR”** shows the time it took for the fault to clear in the HISTORY buffer.

**“COMPRESSOR SYSTEM (1,2, OR 3)TIME OUT”** – If the **“COMPR STATUS CLEAR TIME (1,2, OR 3)”** timer reaches 60 minutes a **“COMPRESSOR SYSTEM (1,2, OR 3) TIME OUT”** will be indicated in the HISTORY buffer. In most cases this indicates the compressor circuit over current protector opened. The com-

pressor circuit over current protector is a manual reset device and the circuit would not reset in the required 60 minute time frame. The STATUS key will display the message **“COMP SYS (1,2, OR 3) STATUS” “SAFETY LOCKOUT”**. The Unit Controller locks out the corresponding compressor system when a **“COMPRESSOR SYSTEM (1,2, OR 3)TIME OUT”** is declared.

**“COMPR SYSTEM (1,2, OR 3) INHIBIT”** – This WARNING indicates the compressor system safety circuit experienced a trip but reset prior to the exploration of the 60 minute reset time function. If the safety circuit does not reset in 60 minutes it will be replaced with a **“COMPRESSOR SYSTEM (1,2, OR 3)TIME OUT”** message.

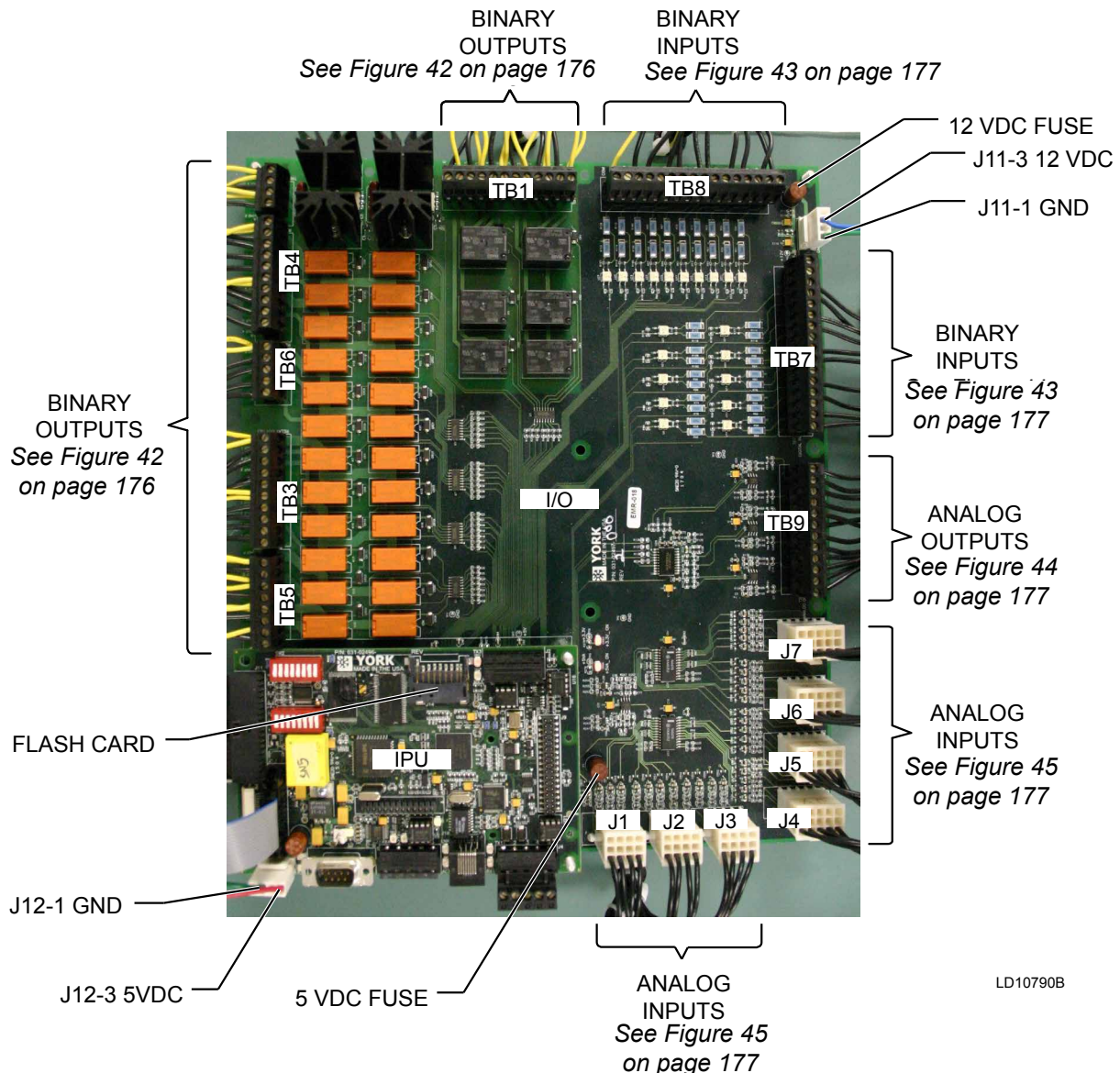

**FIGURE 41 - I/O CONTROL BOARD**

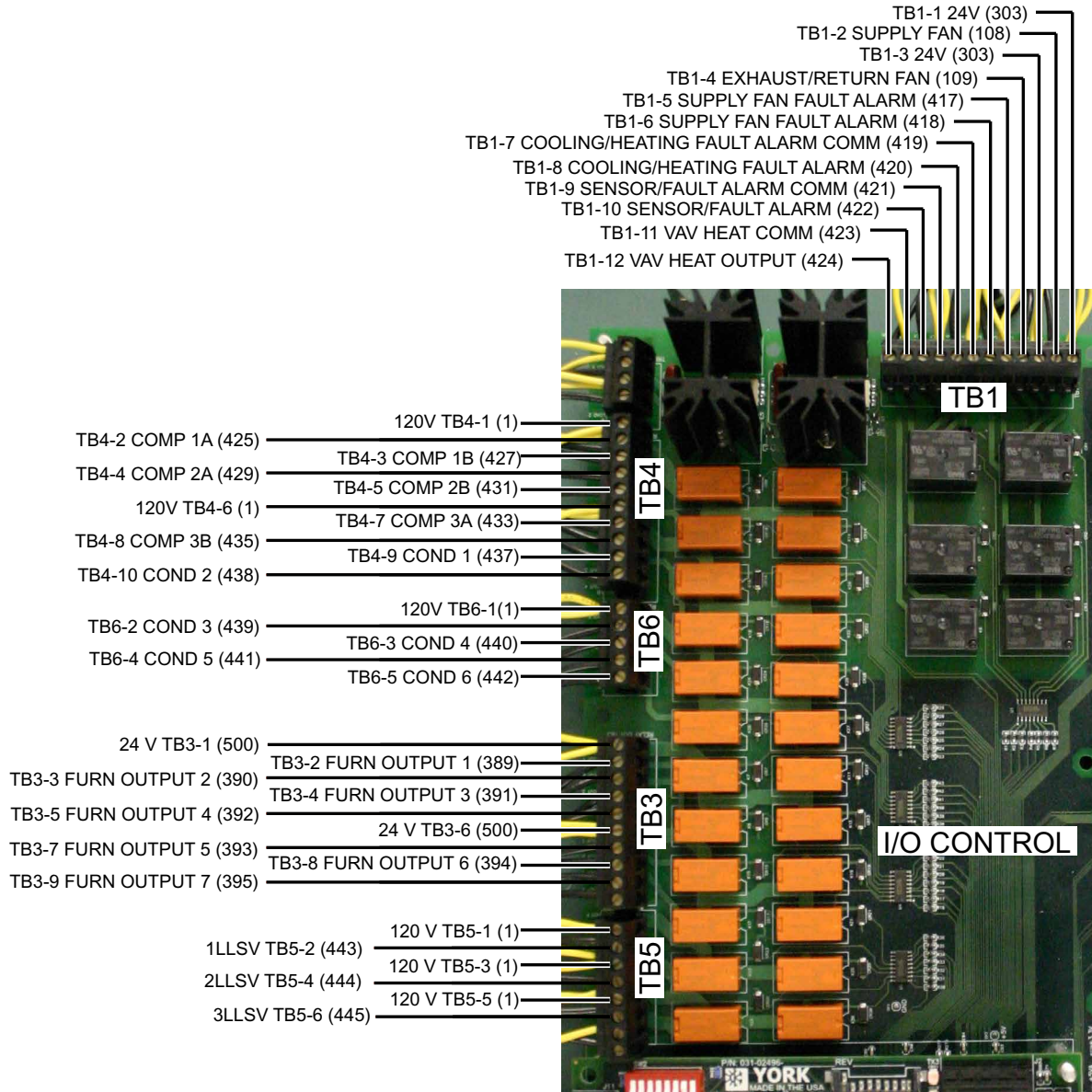

LD10791C

FIGURE 42 - I/O CONTROL BOARD - BINARY OUTPUTS



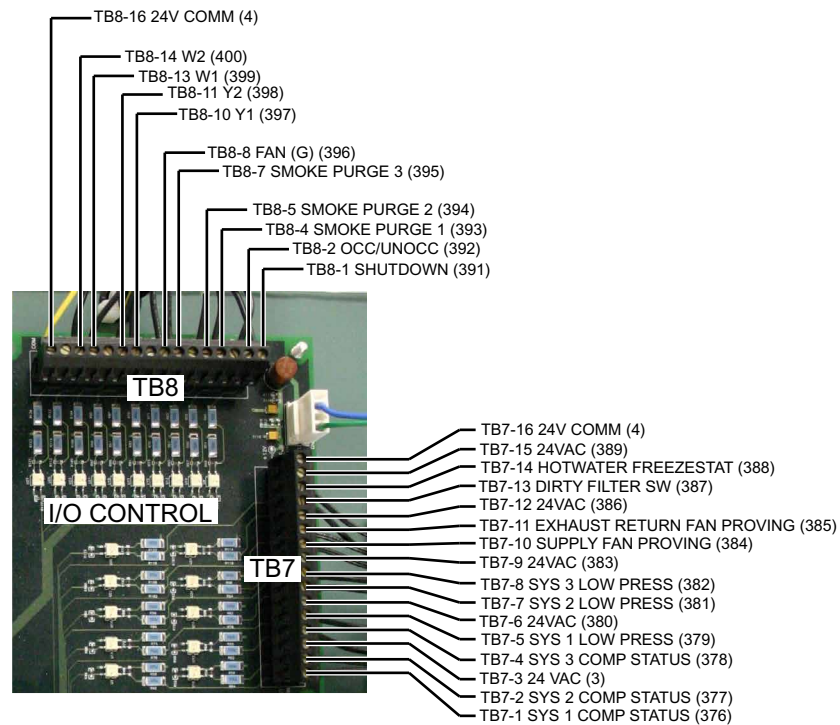

LD10792B

FIGURE 43 - I/O CONTROL BOARD - BINARY INPUTS

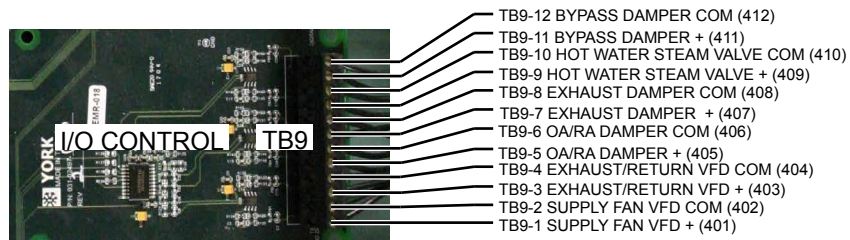

LD10793A

FIGURE 44 - I/O CONTROL BOARD - ANALOG OUTPUTS

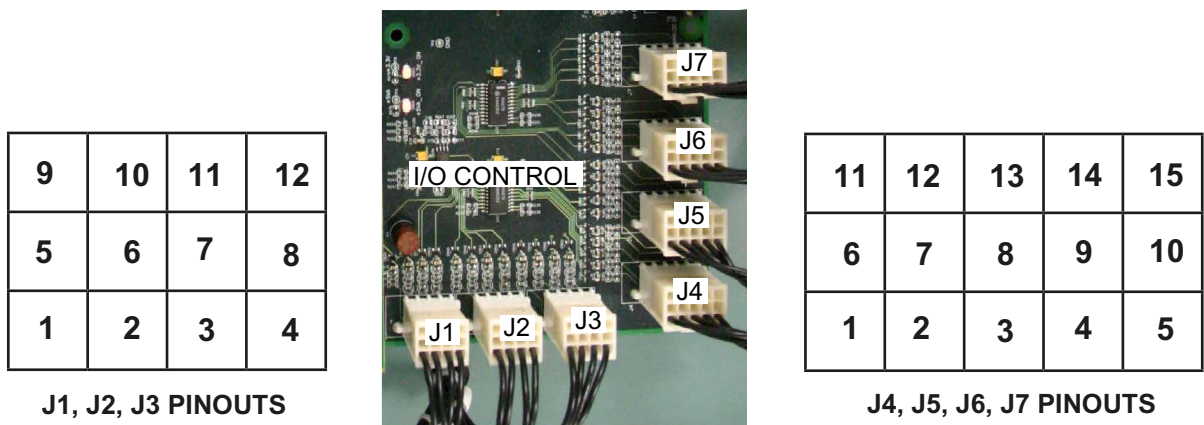

LD10794A

FIGURE 45 - I/O CONTROL BOARD - ANALOG INPUTS (SEE TABLE 50 FOR PIN OUTS)

**TABLE 50 - I/O CONTROL BOARD - ANALOG INPUT PIN OUTS**

PIN NUMBER	SIGNAL
J1-1	Input Supply Air Temp (308)
J1-5	Shield Supply Air Temp
J1-9	Ref Supply Air Temp 5VDC (309)
J1-2	Input Heat Enter Temp (310)
J1-6	Shield Heat Enter Temp
J1-10	Ref Heat Enter Temp 5VDC (311)
J1-3	Input Flex Evap Temp (312)
J1-7	Shield Flex Evap Temp
J1-11	Ref Flex Evap Temp 5VDC (313)
J2-1	Input Outside Air Temp (314)
J2-5	Shield Outside Air Temp
J2-9	Ref Outside Air Temp 5VDC (315)
J2-2	Input Return Air Temp (316)
J2-6	Shield Return Air Temp
J2-10	Ref Return Air Temp 5VDC (317)
J2-3	Input OA Hum (318)
J2-7	Com OA Hum (319)
J2-4	Input RA Hum (320)
J2-8	Com RA Hum (321)
J3-1	Input Suct Temp Sys1 (322)
J3-5	Shield Suct Temp Sys1
J3-9	Ref Suct Temp Sys1 5VDC (323)
J3-2	Input Suct Temp Sys2 (324)
J3-6	Shield Suct Temp Sys2
J3-10	Ref Suct Temp Sys2 5VDC (325)
J3-3	Input Suct Temp Sys3 (326)
J3-7	Shield Suct Temp Sys3
J3-11	Ref Suct Temp Sys3 5VDC (327)
J3-4	Input Suct Press Sys1 (328)
J3-8	Com Suct Press Sys1 (329)
J3-12	Ref Suct Press Sys1 5VDC (330)
J4-1	Input Suct Press Sys2 (331)
J4-6	Com Suct Press Sys2 (332)
J4-11	Ref Suct Press Sys2 5VDC (333)
J4-2	Input Suct Press Sys3 (334)
J4-7	Com Suct Press Sys3 (335)
J4-12	Ref Suct Press Sys3 5VDC (336)
J4-3	Input Disch Press Sys1 (337)
J4-8	Com Disch Press Sys1 (338)

PIN NUMBER	SIGNAL
J4-13	Ref Disch Press Sys1 5VDC (339)
J4-4	Input Disch Press Sys2 (340)
J4-9	Com Disch Press Sys2 (341)
J4-14	Ref Disch Press Sys2 5VDC (342)
J4-5	Input Disch Press Sys3 (343)
J4-10	Com Disch Press Sys3 (344)
J4-15	Ref Disch Press Sys3 5VDC (345)
J5-1	Input Gas Heat Status (542)
J5-6	Com Gas Heat Status (543)
J5-11	Ref Gas Heat Status 5VDC (541)
J5-2	Input OA Co2 (348)
J5-7	Com OA Co2 (349)
J5-3	Input RA Co2 (350)
J5-8	Com RA Co2 (351)
J6-1	Input Return Fan Press (352)
J6-6	Com Return Fan Press (353)
J6-2	Input Duct Press (354)
J6-7	Com Duct Press (355)
J6-3	Input Bldg Press (356)
J6-8	Com Bldg Press (357)
J6-4	Input OA Air Press 1 (358)
J6-9	Com OA Air Press 1 (359)
J6-5	Input OA Air Press 2 (360)
J6-10	Com OA Air Press 2 (361)
J7-1	Input Zone Temp Sensor (363)
J7-6	Shield Zone Temp Sensor (364)
J7-11	Ref Zone Temp Sensor 5VDC (362)
J7-2	Input Flexsys Slab Sensor (366)
J7-7	Shield Flexsys Slab Sensor (367)
J7-12	Ref Flexsys Slab Sensor 5VDC (365)
J7-3	Input Flexsys Under Floor Hum (368)
J7-8	Com Flexsys Under Floor Hum (369)
J7-4	Input Sat Reset (371)
J7-9	Com Sat Reset (372)
J7-14	Ref Sat Reset 5VDC (370)
J7-5	Input Duct Static Reset (374)
J7-10	Com Duct Static Reset (375)
J7-15	Ref Duct Static Reset 5VDC (373)

**TABLE 51 - WARNING DESCRIPTION TABLE**

HISTORY SCREEN WORDING	DESCRIPTION	RESET	SHOW WHEN UNIT TYPE IS	STATUS SCREEN WORDING	FAULT OUTPUT TYPE
<b>WRN-BUILDING PRS</b>	Building static pres > 0.45" W.C. or < -0.45" W.C. for 10 seconds. Power exhaust reverts to none or on/off	Auto Reset	Power Exhaust Other Than None Or On - Off Damper	Exhaust Sys Status Warning	Sensor/ Misc Fault
<b>WRN-CO2 SENSOR 1 OUTSIDE</b>	Outside CO <sub>2</sub> sensor out of range for >= 15 minutes	Auto Reset	Ventilation Control Equals Demand	Ventilation Sys Status Warning	Sensor/ Misc Fault
<b>WRN-CO2 SENSOR 2 INSIDE</b>	Outside CO <sub>2</sub> sensor out of range for >= 15 minutes	Auto Reset	Ventilation Control Equals Demand	Ventilation Sys Status Warning	Sensor/ Misc Fault
<b>WRN-COMPR SYSTEM * INHIBIT</b>	See description at the end of this table	Auto Reset			Cooling Heating Fault
<b>WRN-DIRTY FILTER 1</b>	The filter status input is closed for >= 1 minute	Auto Reset	Dirty Filter Switch Is Installed	Filter Status Change	Sensor/ Misc Fault
<b>WRN-DISCHARGE PRS SENSOR *</b>	The discharge pressure for that system is out of range for >= 10 seconds	Auto Reset	Press Trans Pkg Is On For The System	Sensor/ Misc Status Warning	Sensor/ Misc Fault
<b>WRN-DUCT PRS XDCR</b>	Supply fan output on, supply fan status must be running for 5 minutes, static press current <=(0.333 X duct static press active sp) for 30 seconds	Auto Reset	Unit Type Is VAV Or FlexSys	Supply Sys Status Warning	Fan Fault
<b>WRN-EXHAUST FAN</b>	The exhaust fan output is on for 45 seconds and the run verification input is low (open) for 10 seconds	Auto Reset	Power Exhaust Other Than None	Exhaust System Status Warning	Sensor/ Misc Fault
<b>WRN-FREEZESTAT TRIP</b>	The hw/steam freezestat circuit goes high (closed) but goes low (open) within 5 minutes	Auto Reset	Heating System Type Equals Hot Water Steam	Sensor/ Misc Status Warning	Cooling Heating Fault
<b>WRN-FURNACE MULTIPLEXER FAULT</b>	On modulating gas the heat binary outputs do not match the gas furnace status input. See <i>Table 49 on page 173</i> for furnace status input on staged heat	Auto Reset	Heating System Type Equals Modulating Gas Or Staged Gas	Sensor/ Misc Status Warning	Cooling Heating Fault
<b>WRN-GAS FURNACE</b>	The heat binary outputs do not match the gas furnace status input. See <i>Table 49 on page 173</i>	Auto Reset	Heating System Type Equals Staged Gas		Cooling Heating Fault
<b>WRN-HET SENSOR</b>	The heat entering sensor is out of range for >= 10 seconds	Auto Reset	Heating System Type Is Staged Gas Or Electric	Sensor/ Misc Status Warning	Sensor/ Misc Fault
<b>WRN-HIGH DP UNLOAD *#</b>	Both compressor are on for the system and the discharge press is >= to the system unloading pressure for 10 seconds	Auto Reset	Press Trans Pkg Is On For The System	Sensor/ Misc Status Warning	Sensor/ Misc Fault
<b>WRN-LOW AMBIENT TEMP *</b>	The outdoor temp is <= to the mech cool lockout temp	Auto Reset	Low Ambient Pkg Is Not Installed For The System	Comp Sys * Status Low Amb Inhibit	Sensor/ Misc Fault
<b>WRN-LOW SUCTION TEMP *#</b>	The suction temp is less than the suction temp low limit for 10 continuous seconds	Auto Reset		Comp Sys * Status Suction Temp Unl # On	Sensor/ Misc Fault

**TABLE 51 – WARNING DESCRIPTION TABLE (CONT'D)**

HISTORY SCREEN WORDING	DESCRIPTION	RESET	SHOW WHEN UNIT TYPE IS	STATUS SCREEN WORDING	FAULT OUTPUT TYPE
<b>WRN-OA FLOW PRS 1</b>	Refer to air measurement station sensor faults in <i>SECTION 5 – SEQUENCE OF OPERATION</i> of the manual	Locks Out The Air Measuring Station	Damper Hardware Is Minimum laq, Full laq, 1/3-2/3 laq, Tek Air Full laq	Sensor/ Misc Status Warning	Sensor/ Misc Fault
<b>WRN-OA FLOW PRS 2</b>	Refer to air measurement station sensor faults in <i>SECTION 5 – SEQUENCE OF OPERATION</i> of the manual	Locks Out The Air Measuring Station	Damper Hardware Is 1/3 - 2/3 laq	Sensor/ Misc Status Warning	Sensor/ Misc Fault
<b>WRN-OUTSIDE AIR RH</b>	Outside air temp $\geq 32.0$ °F for 10 seconds outdoor air humidity $< 5\%$ for 10 seconds	Auto Reset	Econo Installed Single Enthalpy Or Dual Enthalpy	Sensor/ Misc Status Warning	Sensor/ Misc Fault
<b>WRN-RETURN AIR RH</b>	Return air temp $\geq 32.0$ °F for 10 seconds return air humidity $< 5\%$ for 10 seconds	Auto Reset	Econo Installed Dual Enthalpy	Sensor/ Misc Status Warning	Sensor/ Misc Fault
<b>WRN-RETURN FAN XDCR</b>	Supply fan output is on and return fan press current $< -0.95$ " W.C. or $> 0.95$ " W.C. for 30 seconds or supply fan output is off and return fan pressure current $< -0.1$ " W.C. or $> 0.1$ " W.C. for 5 minutes	Auto Reset	Power Exhaust Type Is Return Fan W/Exh Or Return Fan W/O Exh	Supply Sys Status Warning	Fan Fault
<b>WRN-SLAB TEMP SENSOR</b>	Underfloor slab temp sensor is out of range for $\geq 10$ seconds	Auto Reset	Unit Type Is FlexSys And Dew Point Reset Is User Enabled	Sensor/ Misc Status Warning	Sensor/ Misc Fault
<b>WRN-SUCTION PRS SENSOR *</b>	Suction pressure out of range for $\geq 10$ seconds	Auto Reset	Press Trans Pkg Is On For The System	Sensor/ Misc Status Warning	Sensor/ Misc Fault
<b>WRN-SUCTION TEMP SENSOR * #</b>	Suction temperature sensor is out of range for $\geq 10$ seconds	Auto Reset		Sensor/ Misc Status Warning	Sensor/ Misc Fault
<b>WRN-UNDER FLOOR RH SENSOR</b>	Underfloor air humidity is $< 5\%$ for $\geq 5$ minutes	Auto Reset	Unit Type Is FlexSys And Dew Point Reset Is User Enabled	Sensor/ Misc Status Warning	Sensor/ Misc Fault

\* Can Be 1, 2, Or 3 # Can Be A Or B

**TABLE 52 - FAULT AUTO - RESET**

HISTORY SCREEN WORDING	DESCRIPTION	RESET	HOW WHEN UNIT TYPE IS	STATUS SCREEN WORDING	FAULT OUTPUT TYPE
<b>AUTO RESET-COMPRESSOR SYSTEM * CLEAR</b>	See description below	Auto Reset			
<b>AUTO RESET-COMPRESS SYSTEM * TRIP 1</b>	The safety input chain is open (faulted) for more then two seconds with either or both compressor of the system on and this is the first trip in a 120 minute span	Auto Reset		Comp System * Status Safety Trip	Cooling Heating Fault
<b>AUTO RESET COMPRESSOR SYSTEM * TRIP 2</b>	The safety input chain is open (faulted) for more then two seconds with either or both compressor of the system on and this is the second trip in a 120 minute span	Auto Reset		Comp System * Status Safety Trip	Cooling Heating Fault
<b>AUTO RESET-LOW SUCTION TEMP</b>	Either is compressor on and the temperature - suction is less than or equal to the suction low limit for 10 continuous seconds and after the compressor was turned off the temperature did not rise above the limit.	Auto Reset		Comp System * Status Safety Fault	Sensor/ Misc Fault
<b>AUTO RESET-LPCO * TRIP 1</b>	The low pressure cutout input chain is open (faulted) for more then two seconds with either or both compressor of the system on and this is the first trip in a 120 minute span	Auto Reset		Comp System * Status Safety Trip	Cooling Heating Fault
<b>AUTO RESET-LPCO * TRIP 2</b>	The low pressure cutout input chain is open (faulted) for more then two seconds with either or both compressor of the system on and this is the second trip in a 120 minute span	Auto Reset		Comp System * Status Safety Trip	Cooling Heating Fault
<b>AUTO RESET - MSAT SENSOR</b>	MS supply air temp current sensor is out of range for >= 10 seconds.	Auto Reset	Unit Type Is FlexSys	Sensor/Misc Status Safety Lockout	Sensor/ Misc Fault
<b>AUTO RESET - POWER FAIL</b>	Power is lost when the unit operating state is run	Auto Reset			
<b>AUTO RESET - RAT SENSOR</b>	Return air temp current sensor is out of range for >= 10 seconds	Auto Reset		Sensor/Misc Status Safety Fault	Sensor/ Misc Fault
<b>AUTO RESET - REMOTE I/O COMM</b>	No communication from the i/o board for >= 5 seconds	Auto Reset			Sensor/ Misc Fault
<b>AUTO RESET - STAGED INPUT</b>	The control has a cooling and heating thermostat input at the same time for a period greater than 10 seconds	Auto Reset		Sensor/Misc Status Safety Lockout	Sensor/ Misc Fault
<b>AUTO RESET - ZONE TEMP SENSOR</b>	Zone temp current sensor is out of range for >= 10 seconds	Auto Reset	Unit Type Is VAV And Night Set Back is User Enabled Or Unit Type Is Set To CV And The Control Method Is Set To Zone Sensor Hardwired	Sensor/Misc Status Safety Lockout	Sensor/ Misc Fault

\* Can Be 1, 2, Or 3

**TABLE 53 - FAULTS LOCKOUT**

HISTORY SCREEN WORDING	DESCRIPTION	RESET	SHOW WHEN UNIT TYPE IS	STATUS SCREEN WORDING	FAULT OUTPUT TYPE
<b>LOCKOUT-COMPRESSOR SYSTEM * TIME OUT</b>	See below	System Lockout		Comp System * - Safety Lockout	Cooling Heating Fault
<b>LOCKOUT - COMPRESSOR SYSTEM *</b>	High press SW, comp motor protector, or overcurrent protector open - 3 times in 120 minutes on comp system *	System Lockout		Comp System * - Safety Lockout	Cooling Heating Fault
<b>LOCKOUT-HIGH DUCT PRESSURE</b>	Duct static press current .+ Duct static over pressure	Unit Lockout	Unit Type Is VAV Or FlexSys	Supply Sys Status Safety Lockout	Fan Fault
<b>LOCKOUT - HOT WATER FREEZE</b>	The hydronic freeze stat switch remained closed >= 5 minutes	Unit Lockout	Heat Type Hot Water / Steam	Heating Sys Status - Safety Lockout	Cooling Heating Fault
<b>LOCKOUT-LPCO</b>	Low pressure cutout open - 3 times in 120 minutes on compr system *	System Lockout		Comp System * - Safety Lockout	Cooling Heating Fault
<b>LOCKOUT - MANUAL STOP *</b>	The compressor system has been placed in the stop mode either through the user interface or by a communicated input	System Lockout		Comp Sys * Status Disabled	
<b>LOCKOUT - MANUAL UNIT STOP</b>	The unit is shut down through the shut down switch on the unit or by an external hardwired or communicated input	Unit Lockout		Unit - Overall Status Local Stop	
<b>LOCKOUT - OAT SENSOR</b>	Outside air temp sensor is out of range for >= 10 seconds	Unit Lockout		Comp Sys * Status Safety Lockout; Econo Sys Status Safety Lockout	Sensor/ Misc Fault
<b>LOCKOUT - RETURN FAN</b>	Return fan status is low and time from start >= 30 sec unit lockout	Unit Lockout	Power Exhaust Type Is Return Fan W/Exh Or Return Fan W/O Exh And The Supply Fan Is On	Unit - Overall Status Unit Lockout	Fan Fault
<b>LOCKOUT - SAT SENSOR</b>	Supply air temp current sensor is out of range for >= 10 seconds	Unit Lockout	Unit Type Is Constant Volume Or Variable Air Volume		Sensor/ Misc Fault
<b>LOCKOUT-SUPPLY FAN</b>	Supply fan status is low and time from start > = 30 sec unit lockout	Unit Lockout		Unit - Overall Status Unit Lockout	Fan Fault

\* Can be 1, 2, or 3

“WRN - COMP SYSTEM \* INHIBIT” - This WARNING indicates the compressor system safety circuit experienced a trip but reset prior to the expiration of the 60 minute reset time function. If the safety circuit does not reset in 60 minutes it will be replaced with a “LOCKOUT - COMPRESSOR SYSTEM \* TIME OUT” message.

“AUTO RESET - COMPRESSOR SYSTEM \* CLEAR” - Whenever there is a compressor safety trip the Primary Unit Controller initiates the “COMPR STATUS CLEAR TIME \*\*” timer. The Primary Unit Controller records the time it takes for the trip to clear. When the fault clears “COMPRESSOR SYSTEM \* CLEAR” shows the time it took for the fault to clear in the HISTORY buffer.

“LOCKOUT-COMPRESSOR SYSTEM \* TIME OUT” – If the “COMPR STATUS CLEAR TIME \*\*” timer reaches 60 minutes a “LOCKOUT - COMPRESSOR SYSTEM \* TIME OUT” will be indicated in the HISTORY buffer.

## MULTI MEDIA CARD

The Unit Controller is made up of two separate control boards, the PLUG IN I/O board and the IPU board. All the digital and analog inputs and outputs are connected to the PLUG IN I/O control. All the system logic is contained on the PLUG IN I/O board. The IPU board mounts on top of the PLUG IN I/O board and handles the communication between the PLUG IN I/O board and the User Interface. Another feature of this control system is the availability to connect a MULTI MEDIA CARD to the IPU board. The MULTI MEDIA CARD allows operational data to be continuously saved and used for the diagnosis of unit operating problems.

A MULTI MEDIA CARD is similar to a hard drive in a PC. It has a directory structure and files are saved on it. The difference between a hard drive and the MULTI MEDIA CARD is that the MULTI MEDIA CARD is made of non-volatile flash memory. This allows the MULTI MEDIA CARD to be removed from the IPU board and placed in a PC for data analysis without the loss of any data.

The MULTI MEDIA CARD is considered a Service tool and as such is controlled through the SERVICE key of the User Interface. Entry into the SERVICE screen requires a Level 2 password.

Data is continuously stored to the MULTI MEDIA CARD in root and subdirectories. The root directories are set up by month and year, under each of the root directories are subdirectories for each day. For example the data for January 11, 2005 would be stored in a root directory identified by Rm200501, the year followed by the month. The subdirectory for this day would be identified as 20050111.csv, the year followed by the month, followed by the day. Each of these files contains all the data monitored for the day specified by the file name.

All connected Analog Inputs, Analog Outputs, Digital Inputs, Digital Outputs, Serial Data and Derived Data will be collected. The data will be collected once every 5 seconds and stored in the same order as in the History buffer. Each line of data will be timed and date stamped. Each file will include a header line detailing what data is stored in each column.

The collected data can be analyzed using a PC. The MULTI MEDIA CARD can be inserted into a MULTI MEDIA CARD reader attached to the PC. The data can be analyzed using Excel or another data analysis tool.

To install or remove the MULTI MEDIA CARD from the IPU board “*DATA LOG FORMAT*” must be set to OFF. This is done through the SERVICE screen of the User Interface. When the MULTI MEDIA CARD is installed the operation can be programmed to “*UNCOMPRESSED*” in which case data will be recorded every 5 seconds or “*SKIP UNCHANGED*” which is the same as “*UNCOMPRESSED*” except values are only saved when they change.

If an error occurs when writing to the MULTI MEDIA CARD, “*DATA LOG ERROR STATE*” and “*DATA LOG ERROR DETAIL*” will appear under the SERVICE screen. “*DATA LOG ERROR STATE*” indicates what operation failed and “*DATA LOG ERROR DETAIL*” will give the error code from the operation. *Table 54 on page 184* gives a description of the “*DATA LOG ERROR STATE*” and *Table 55 on page 184* gives a description of the “*DATA LOG ERROR DETAIL*”.

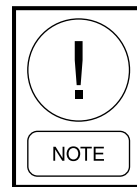

***The SD card cannot exceed 2 MB for data logging or software updates. Not all SD cards are compatible with the IPU system.***

**TABLE 54 - DATA LOG ERROR STATE**

DATA LOG ERROR STATE	AN ERROR OCCURRED WHEN DOING THIS:
1	Mounting the flash card
2	Opening the root directory
3	Reading the root directory
4	Closing the root directory
5	Opening a sub-directory
6	Reading a sub-directory
7	Closing a sub-directory
8	Deleting an old directory
11	Creating a directory
14	Creating a file
15	Open a file
16	Write a file
17	Delete a file
18	Close a file

**TABLE 55 - DATA LOG ERROR LOG DETAIL**

DATA LOG ERROR DETAIL	THIS ERROR OCCURRED:
1	Not permitted
2	No such entity
3	No such process
4	Operation interrupted
5	I/O error
6	Bad file handle
11	Try again later
12	Out of memory
16	Resource busy
19	No such device
20	Not a directory
21	Is a directory
22	Invalid argument
23	Too many open files in system
27	File too large
28	No space left on device
29	Illegal seek
30	Read-only file system
60	File name too long



The following factors can be used to convert from English to the most common SI Metric values.

**TABLE 56 - SI METRIC CONVERSION**

MEASUREMENT	MULTIPLY ENGLISH UNIT	BY FACTOR	TO OBTAIN METRIC UNIT
Capacity	Tons Refrigerant Effect (ton)	3.516	Kilowatts (kW)
Power	Horsepower	0.7457	Kilowatts (kW)
Flow Rate	Gallons / Minute (gpm)	0.0631	Liters / Second (l/s)
Length	Feet (ft)	0.3048	Meters (m)
	Inches (in)	25.4	Millimeters (mm)
Weight	Pounds (lbs)	0.4538	Kilograms (kg)
Velocity	Feet / Second (fps)	0.3048	Meters / Second (m/s)
Pressure Drop	Feet of Water (ft)	2.989	Kilopascals (kPa)
	Pounds / Square Inch (psi)	6.895	Kilopascals (kPa)

## TEMPERATURE

To convert degrees Fahrenheit (°F) to degrees Celsius (°C), subtract 32° and multiply by 5/9 or 0.5556.

Example:  $(45.0\text{ }^{\circ}\text{F} - 32^{\circ}) \times 0.5556 = 7.22\text{ }^{\circ}\text{C}$

To convert a temperature range (i.e., a range of 10.0 °F) from Fahrenheit to Celsius, multiply by 5/9 or 0.5556.

Example:  $10.0\text{ }^{\circ}\text{F range} \times 0.5556 = 5.6\text{ }^{\circ}\text{C range}$



P.O. Box 1592, York, Pennsylvania USA 17405-1592  
Copyright © by Johnson Controls 2016  
Form 100.50-NOM9 (116)  
Issue Date: January 7, 2016  
Supersedes: 100.50-NOM9 (1115)

800-861-1001  
[www.johnsoncontrols.com](http://www.johnsoncontrols.com)

Subject to change without notice. Printed in USA  
ALL RIGHTS RESERVED